

# Operating Instructions & Parts Manual

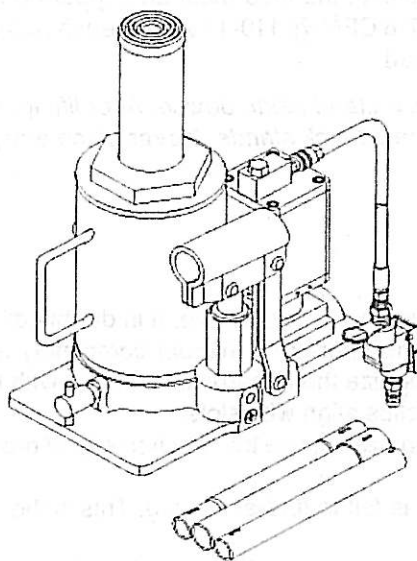

14475

## 30 Ton Air Hydraulic Bottle



This is the safety alert symbol. It is used to alert you to potential personal injury hazards. Obey all safety messages that follow this symbol to avoid possible injury or death.

### ADVERTENCIA

- Leer, comprender, y seguir las instrucciones antes de utilizar el aparato.
- El manual de instrucciones y la información de seguridad deben estar comunicado en lengua del operador antes del uso.
- No seguir estas indicaciones puede causar daños personales o materiales.

### WARNING

To avoid crushing and related injuries:



- NEVER work on, under or around a load supported only by a hydraulic jack.
- ALWAYS use adequately rated jack stands.

Read this manual and follow all the Safety Rules and Operating Instructions before using this product.

## SAFETY and GENERAL INFORMATION

Save these instructions. For your safety, read, understand, and follow the information provided with and on this jack before using. The owner and operator of this equipment shall have an understanding of this jack and safe operating procedures before attempting to use. The owner and operator shall be aware that use and repair of this product may require special skills and knowledge. Instructions and safety information shall be conveyed in the operator's native language before use of this jack is authorized. If any doubt exists as to the safe and proper use of this jack, remove from service immediately.

**Inspect before each use.** Do not use if broken, bent, cracked or damaged parts are noted. Any jack that appears damaged in any way, or operates abnormally shall be removed from service immediately. If the jack has been or suspected to have been subjected to a shock load (a load dropped suddenly, unexpectedly upon it), immediately discontinue use until jack has been checked by a factory authorized service center (contact distributor or manufacturer for list of authorized service centers). It is recommended that an annual inspection be done by qualified personnel. Labels and Operator's Manuals are available from manufacturer.

## PRODUCT DESCRIPTION

AME Air Actuated Hydraulic Bottle Jacks are designed to lift, not support, rated capacity loads consisting of one end of a vehicle. Immediately after lifting, the load must be supported by a pair of appropriately rated jack stands. Ensure that air source can dedicate 7.8 CFM @ 110-175 psi to each jack operated. A minimum of 150 psi air pressure is required to raise rated capacity load.

 **Never use hydraulic jack as a stand alone device. After lifting, immediately support the lifted load with a pair of appropriately rated jack stands. Never place any portion of your body under a load when lifting or lowering the load.**

## PREPARATION

### Before Use

1. Verify that the product and application are compatible, if in doubt call AME Technical Service.
2. Before using this product, read the operator's manual completely and familiarize yourself thoroughly with the product, its components and recognize the hazards associated with its use.
3. Assemble handle, ensure spring clips align with slots.
4. To familiarize yourself with basic operation, use the notched end of provided handle to engage and turn the release valve:
  - a. Clockwise until firm resistance is felt to further turning. This is the '**CLOSED**' release valve position used to **raise** the ram plunger.
  - b. Counter-clockwise, but no more than 1 turn from the closed position. This is the '**OPEN**' release valve position used to **lower** the ram plunger.
5. With ram fully retracted, locate and remove the oil filler plug/screw. Insert the handle into the handle sleeve, then pump 6 to 8 strokes. Ensure the oil level is just below the oil filler hole. Reinstall the oil filler plug/screw.
6. Pour a teaspoon of good quality, air tool lubricant into the air supply inlet of the lift control valve. Connect to air supply and squeeze lift control valve for 3 seconds to evenly distribute lubricant.
7. This product is equipped with the popular 1/4" NPT air coupler. When installing a different air coupler of your choice, ensure that thread tape or compound is used when servicing connections. To ensure dependable, trouble free operation an inline air dryer and oiler is recommended.
8. Check that the pump operates smoothly and that the extension screw will thread up/down easily before putting into service. Replace worn or damaged parts and assemblies with Omega authorized replacement parts only.

### Bleeding / Venting Trapped Air

With the release valve in the OPEN position (4b above) and with ram plunger fully lowered, locate and remove the oil filler plug/screw. Insert the handle into the handle sleeve; then pump 6 to 8 full strokes. This will help release any pressurized air which may be trapped within the reservoir. Oil level should be even with the bottom of the oil filler hole. Reinstall the oil filler plug/screw.

## ⚠ WARNING

- Study, understand, and follow all printed materials provided with/on this product before use.
- Do not exceed rated capacity.
- This is a lifting device only!
- Immediately after lifting, support the load with a pair of appropriately rated jack stands.
- Use only on hard, level surface.
- Do not use adapters or accessories that are not provided initially.
- Lift only on areas of the vehicle as specified by the vehicle manufacturer.
- Never wire, clamp or otherwise disable the lift control valve to function by other than operator's hand.
- No alterations shall be made to this product.
- Failure to heed these markings may result in personal injury and/or property damage.

## ⚠ WARNING

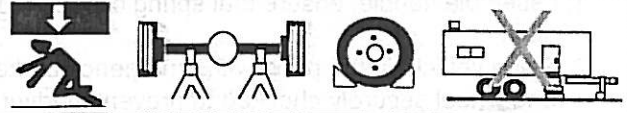

To avoid crushing and related injuries:

- Never work on, under or around a load supported only by hydraulic jack.
- Always use adequately rated jack stands.
- Chock each unlifted tire in both directions.
- Do not use this device to lift, level, lower, support nor move a house, mobile home, travel trailer, camper or any building structure.
- Be alert and sober when using this product. Do not operate under the influence of drugs or alcohol.

⚠ Be sure all tools and personnel are clear before lowering load. Only attachments and/or adapters supplied by the manufacturer shall be used. Lift only on areas of the vehicle as specified by the vehicle manufacturer.

## SPECIFICATIONS

Model	Capacity	Base Size (L x W)	Saddle Diameter	Min. Height	Max. Height	Hydraulic Lift	Ext. Screw
14475	30 Ton	10-1/4" x 8-1/4"	2-1/2"	11"	18-1/8"	7-1/8"	N/A

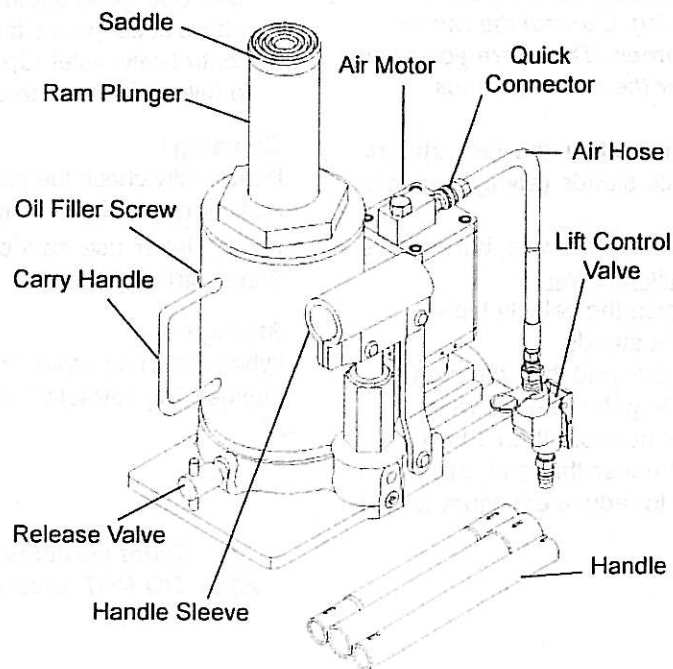

## OPERATION

### Raising the Ram Plunger

1. Assemble handle, ensure that spring clips align with slots.
2. Place vehicle in the park, with emergency brake on and wheel securely chocked to prevent inadvertent vehicle movement.
3. Locate and close release valve by turning handle clockwise until firm resistance is felt to further thread engagement.
4. Verify lift point, center jack saddle under lift point.
5. Squeeze the lift control valve or insert handle into handle sleeve and pump to contact lift point. To lift, continue pumping until load reaches desired height. **DO NOT OPERATE BY AIR AND BY HAND PUMPING AT THE SAME TIME.**
6. **Immediately** transfer the lifted load to a pair of appropriately rated jack stands.

 *Use only handle provided by jack manufacturer. The handle provided with this jack will safely engage the release valve and operate the handle sleeve. If handle is worn, operates abnormally, or will not positively engage the release valve, **STOP**, discontinue use of the jack until a factory replacement handle can be acquired.*

 *Do not use an extender on the air hose or the operating handle.*

### Lowering

 *Make certain that all personnel are clear of the load before lowering. **Control the rate of descent of the load at all times.** The **more** you open the release valve, the **faster** the load descends.*

1. Raise load high enough to clear the jack stands, then carefully remove jack stands (**always** used in pairs).
2. Slowly turn the handle counter-clockwise, but no more than 1 turn. If the load fails to lower:
  - a. Use another jack to raise the vehicle high enough to reinstall jack stands.
  - b. Remove the affected jack and then the stands.
  - c. Lower the load by turning the release valve counter-clockwise, but no more than 1 turn.
3. After removing jack from under the load, push ram and handle sleeve down to reduce exposure to rust and contamination.

## MAINTENANCE

**Important:** Use only good grade hydraulic jack oil. Avoid mixing different types of fluid and **NEVER** use brake fluid, turbine oil, transmission fluid, motor oil or glycerin. Improper fluid can cause premature failure of the jack and the potential for sudden and immediate loss of load. We recommend Mobil DTE 13M or equivalent.

### Adding oil

1. With ram plunger fully lowered and pump piston fully depressed, set jack in its upright, level position. Remove oil filler screw.
2. Fill with oil until just below the rim of the oil filler screw hole. Reinstall the oil filler plug/screw.

### Changing oil

For best performance and longest life, replace the complete fluid supply at least once per year.

1. With ram plunger fully lowered and pump piston fully depressed, remove the oil filler plug/screw.
2. Lay the jack on its side and drain the fluid into a suitable container.  
**Note:** Dispose of hydraulic oil in accordance with local regulations.
3. Fill with oil until just below the rim of the oil filler hole. Reinstall the oil filler plug/screw.

### Lubrication

1. A periodic coating of light lubricating oil to pivot points will help to prevent rust and assure that pump assemblies move freely.
2. Air pump should be internally lubricated before each use. Use good quality air tool lubricant. If no inline oiler is used, pour a teaspoon of air tool oil into the air control valve inlet. Operate the jack with air pressure to fully distribute the oil inside the air motor.

### Cleaning

Periodically check the pump piston and ram for signs of rust/corrosion. Clean as needed and wipe with oily cloth.

**Note:** Never use sandpaper or abrasive material on these surfaces!

### Storage

When not in use, store the jack with pump piston and ram plunger fully retracted and air supply disconnected.

 **Paint contains lead!**  
**DO NOT sand or grind painted surface!**

## TROUBLESHOOTING

Symptom	Possible Causes	Corrective Action
Jack will not lift load	<ul style="list-style-type: none"> <li>• Release valve not tightly closed</li> <li>• Overload condition</li> <li>• Air pressure inadequate</li> </ul>	<ul style="list-style-type: none"> <li>• Ensure release valve tightly closed</li> <li>• Remedy overload condition</li> <li>• Ensure adequate air pressure</li> </ul>
Jack will lift, but not maintain pressure	<ul style="list-style-type: none"> <li>• Release valve not tightly closed</li> <li>• Overload condition</li> <li>• Hydraulic unit malfunction</li> </ul>	<ul style="list-style-type: none"> <li>• Ensure release valve tightly closed</li> <li>• Remedy overload condition</li> <li>• Contact Omega Tech. Service</li> </ul>
Jack will not lower after unloading	<ul style="list-style-type: none"> <li>• Reservoir overfilled</li> </ul>	<ul style="list-style-type: none"> <li>• Ensure load is removed, then drain fluid to proper level</li> </ul>
Poor lift performance	<ul style="list-style-type: none"> <li>• Fluid level low</li> <li>• Air trapped in system</li> </ul>	<ul style="list-style-type: none"> <li>• Ensure proper fluid level</li> <li>• With ram fully retracted, remove oil filler plug/screw to let pressurized air escape, then reinstall oil filler plug/screw</li> </ul>
Will not lift to full extension	<ul style="list-style-type: none"> <li>• Fluid level low</li> </ul>	<ul style="list-style-type: none"> <li>• Ensure proper fluid level</li> </ul>

**Replacement Parts List for Models 14475**

Item	Part# for 18122C	Part# for 18202C	Part# for 18209	Description	Qty.
1	A120-10004-000	A190-10002-000		Cylinder Fastener	1
2	A120-10003-000	A190-10001-000		Guide Ring	1
3a	5905-00100-200	N/A		Filler Plug	1
3b	N/A	G62S-03301-000		Filler Screw	1
4	A120-10002-000			Special Washer	2
5	5905-00054-000			Seal	1
6	BT10-24001-000			Release Valve	1
7	5308-00095-000			Gasket	2
8	A27010-0001	A27060-0003		Air Motor	1
9	A27010-0002	N/A		Air Inlet Swivel	1
10	A20060-0005	A20060-0015		Hose Assy.	1
11	A20060-0006			Air Hose	1
12	A20060-0007			Lift Control Valve	1
13	B020-15002-000			Washer	1
14	B080-15001-000			Pump Cylinder	1
15	A120-15101-000			Pump Piston	1
16	5115-08033-000			Bolt	1
17	5405-07024-000			Pin	1
18	A120-13000-000			Handle Socket	1
19	5405-02018-000			Snap Pin	1
20	B10N-21000-000			Handle Assembly	1
21	A27010-0011	N/A		Air Coupler, Female 1/4 NPT	1
22	A20060-0016			Air Coupler, Male 1/4 NPT	1
23	A27010-0008			Piston, Air Motor	1
24	5206-00008-001			Nut	1
*	A1206S-046	A1906S-047		Seal Kit (includes #4a, 6 & a~l)	-
-	A27010-0000			Seal Kit, Air Motor	-
-	18122C-L0	18202C-L0	18209-L0	Label	1
-	18122C-M2			Manual	1

**(\*) Seal Kit Contents:**

Item	Description	Qty.
3a	Filler Plug (for 18122C only)	1
5	Seal	1
a	Dust Wiper	1
b	O-ring	1
c	O-ring	1
d	Ram Bearing	1
e	Back-up Ring	1

Item	Description	Qty.
f	U-cup	1
g	O-ring	2
h	Packing	1
i	Oil Seal	1
j	O-ring	1
k	Ram Bearing (for 18202C & 18209)	1
l	O-ring (for 18202C & 18209)	1

**Replacement Parts Illustration and Parts List for Model 14475**

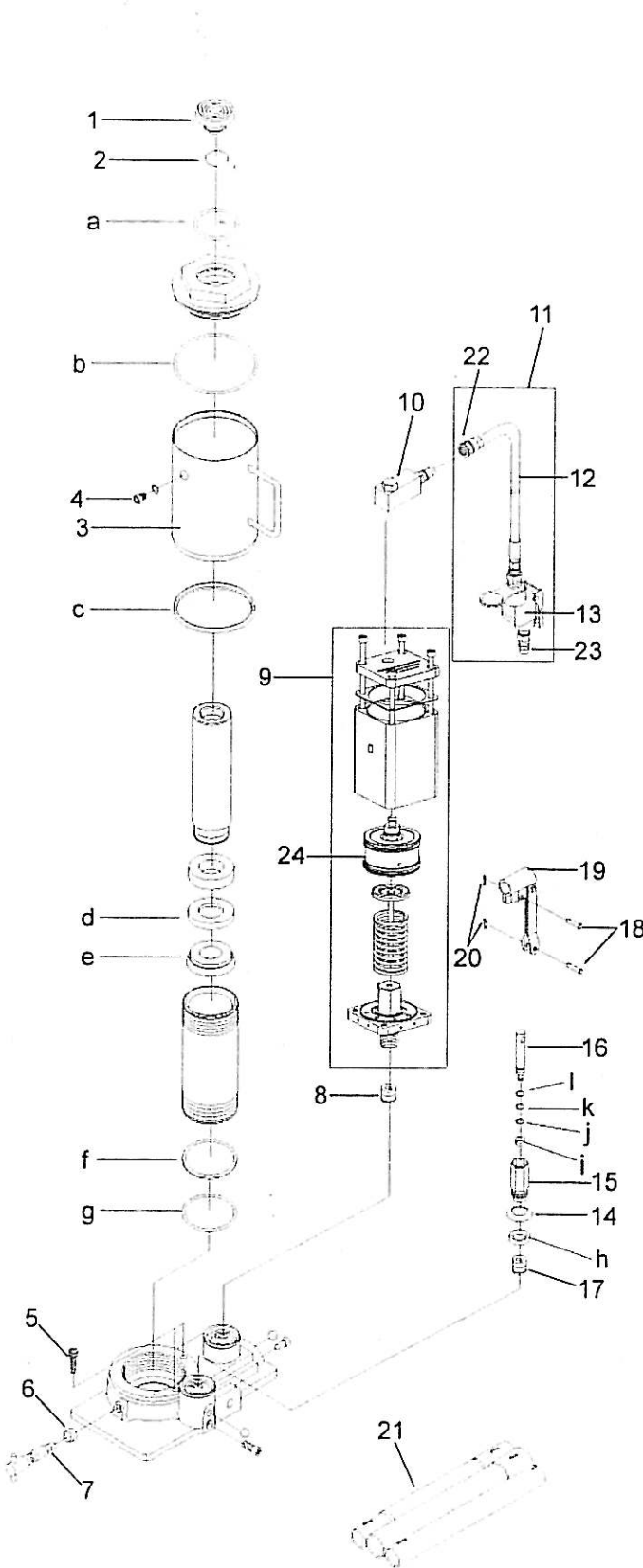

Item	Part# for 18302C	Description	Qty.
1	B300-10003-000	Saddle	1
2	5308-00380-000	Spring	1
3	B300-15000-000	Reservoir	1
4	G62S-03301-000	Filler Screw	1
5	B120-10003-000	Filter	2
6	5905-00054-000	Seal	1
7	BT02-17100-000	Release Valve	1
8	G100-44000-000	Hyd. Cartridge	1
9	A27010-0001	Air Motor	1
10	A27010-0002	Air Inlet Swivel	1
11	A20060-0005	Hose Assy.	1
12	A20060-0006	Air Hose	1
13	A20060-0007	Lift Control Valve	1
14	B300-14002-000	Washer	1
15	B300-14001-000	Pump Cylinder	1
16	B300-14101-000	Pump Piston	1
17	G150-04500-000	Hyd. Cartridge	1
18	5405-08030-000	Pin	2
19	B300-13000-000	Handle Socket	1
20	5405-02018-000	Snap Pin	2
21	B300-17000-000	Handle Assembly	1
22	A27010-0011	Air Coupler, Female	1
23	A20060-0016	Air Coupler, Male	1
24	A270-01100-0000	Piston, Air Motor	1
*	B3000S-034	Seal Kit	-
-	A27010-0000	Seal Kit, Air Motor	-
-	18302C-L0	Label	1
-	18122C-M2	Manual	1

**(\*) Seal Kit Contents:**

Item	Description	Qty.
2	Spring	1
6	Seal	1
a	O-ring	1
b	O-ring	1
c	Packing	1
d	Back-up Ring	1
e	U-cup	1
f	Back-up Ring	1
g	O-ring	1
h	Seal	1
i	U-cup	1
j	Back-up Ring	1
k	Back-up Ring	1
l	O-ring	1

Figure 4 - Model 18302C Replacement Parts Illustration

