

Operating Instructions

Safe-T-Reel Welding Cable Reels

Model Numbers:

T-1460-0 T-1460-2 T-1460-4
 T-1460-7 T-2462-0 T-2464-0



Dimensions

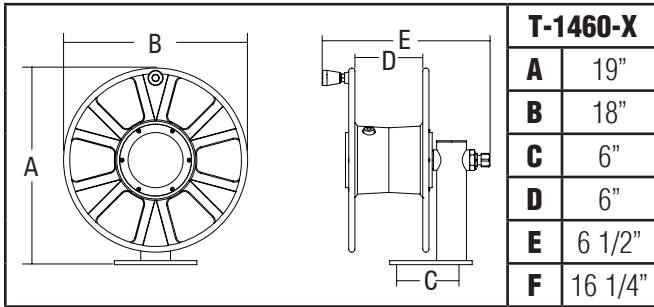

Four 1/2" diameter mounting holes

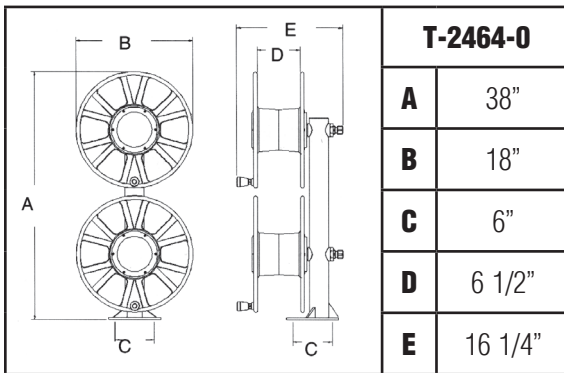

Four 1/2" diameter mounting holes

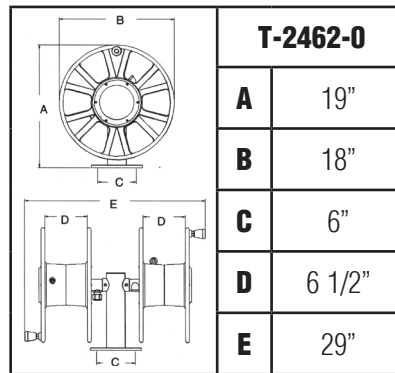

Four 1/2" diameter mounting holes

IMPORTANT

Read this manual carefully before installing, operating or servicing this equipment.

SAFETY

Injury and/or equipment damage may result if proper safety precautions are not observed.

- Ensure that only a qualified electrician installs/services this equipment.
- Ensure that power supply voltage does not exceed maximum voltage rating of reel.
- Ensure that reel is properly installed before connecting to power supply.
- Ensure that all electrical power is removed from reel before servicing.
- Check for frayed/broken wires before each use.
- Pull electrical cord from reel by grasping the electrical cord itself, not the work device.
- If an electrical malfunction should occur, remove power from reel immediately.
- Ensure that reel, electrical cable, and equipment being serviced are properly grounded. Use an ohmmeter to check ground continuity.
- If reel ceases to unwind or rewind, remove power immediately. Do not pull or jerk on electrical cable!
- Treat and respect the cable reel as any other piece of machinery, observing all common safety practices.

WARNING: Even low voltage can cause irreparable damage or death! Exercise extreme caution while operating or servicing this equipment.

Form# 1105-801 Rev: 7/2018

INSTALLATION INSTRUCTIONS

Inspection

Unpack and inspect reel for damage. Turn the reel by hand to check for smooth operation. Check for completeness.

Mounting

Note: Ensure that only a qualified electrician installs/services this equipment.

1. Four 1/2" diameter mounting holes are located at the base of the reel. Mount reel using four (customer supplied) bolts; tightening them securely to ensure a solid, rigid attachment. (Figure 1)

Electrical

Note: Observe any applicable NEC, OSHA, and local electrical codes when installing this equipment.

1. Attach a cable lug (customer supplied) to the end of the outlet cable.
2. Mount lug to collector ring assembly using one 1/2-13 UNC bolt. (Figure 2)

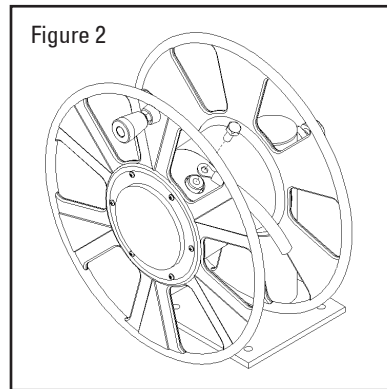
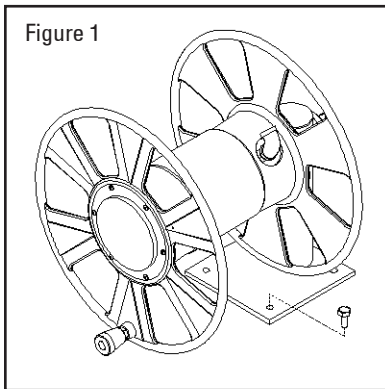

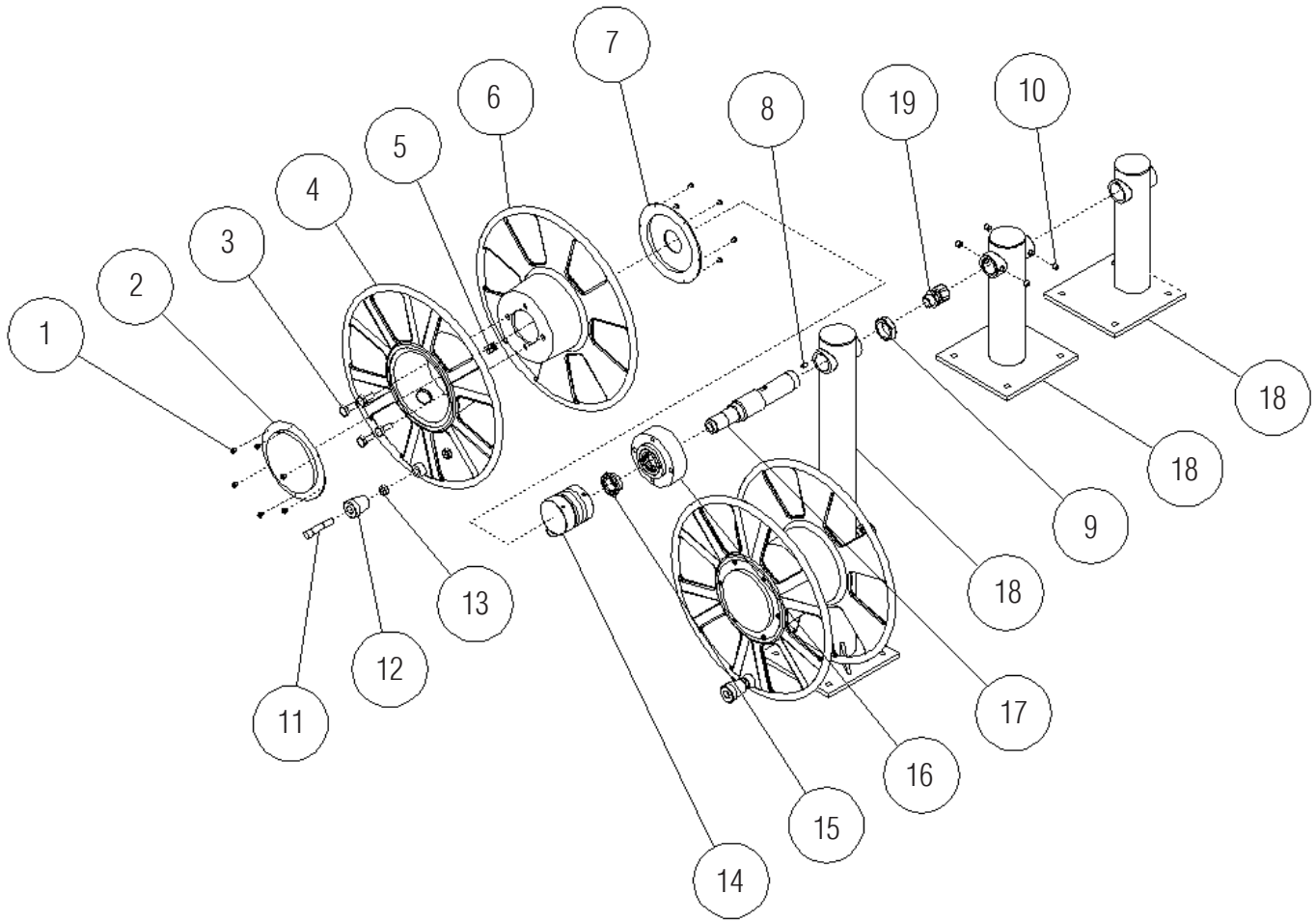

Item #	Description	# Req	T-1460-0	T-1460-2	T-1460-4	T-1460-7	# Req	T-2462-0	T-2464-0
1	Self Tapping Screw	12	S285-14	S285-14	S285-14	S285-14	26	S285-14	S285-14
2	Spool Cover	1	261517	261517	261517	261517	2	261517	261517
3	Hex Cap Screw	5	S2-85	S2-85	S2-85	S2-85	10	S2-85	S2-85
4	Spool Half	1	261546	261546	261546	261546	2	261546	261546
5	Hose Clamp	1	261541-1	261541-1	261541-1	261541-1	2	261541-1	261541-1
6	Spool Half	1	261547	261547	261547	261547	2	261547	261547
7	Spool Cover	1	261518	261518	261518	261518	2	261518	261518
8	Shaft Key	1	261516	261516	261516	261516	2	None	261516
9	Hex Jam Nut	1	261575	261575	261575	261575	2	None	261575
10	Set Screw	---	None	None	None	None	4	S34-184	None
11	Handle Post	1	261515	261515	261515	261515	2	261515	261515
12	Handle	1	261514	261514	261514	261514	2	261514	261514
13	Hex Jam Nut	2	S77-108	S77-108	S77-108	S77-108	4	S77-108	S77-108
14	Collector Ring Assembly	1	S600791	S600791	S600791	S600791	2	S600791	S600791
15	Tensioning Nut	1	261548	261548	261548	261548	2	261548	261548
16	Hub Assembly	1	S600752	S600752	S600752	S600752	2	S600752	S600752
17	Main Shaft	1	261545	261545	261545	261545	2	261562	261545
18	Base Assembly	1	600746	600746	600746	600746	1	600744	600745
19	Cord Grip Assembly	1	261555	261555	261555	261555	2	261555	261555
20	Lock Washer	1	S115-816	S115-816	S115-816	S115-816	2	S115-816	S115-816