

**AMGO**  **Hydraulics**

Original

## Installation And Service Manual

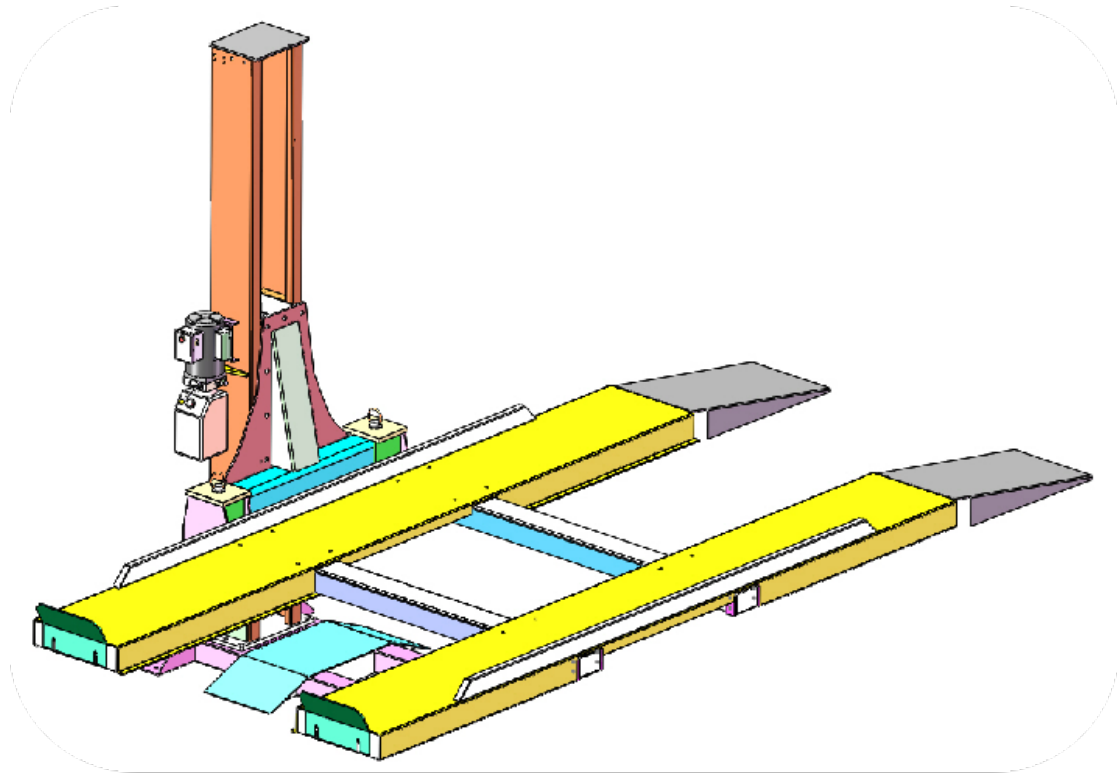

**Single-post Parking Lift Model:  
SPL-6**

# CONTENTS

Product Features and Specifications .....	1
Installation Requirement .....	2
Steps of Installation .....	4
Exploded View .....	13
Test Run .....	22
Operation Instruction .....	24
Maintenance .....	25
Trouble Shooting .....	26
LIFT DISPOSAL .....	26

## I. PRODUCT FEATURES AND SPECIFICATIONS

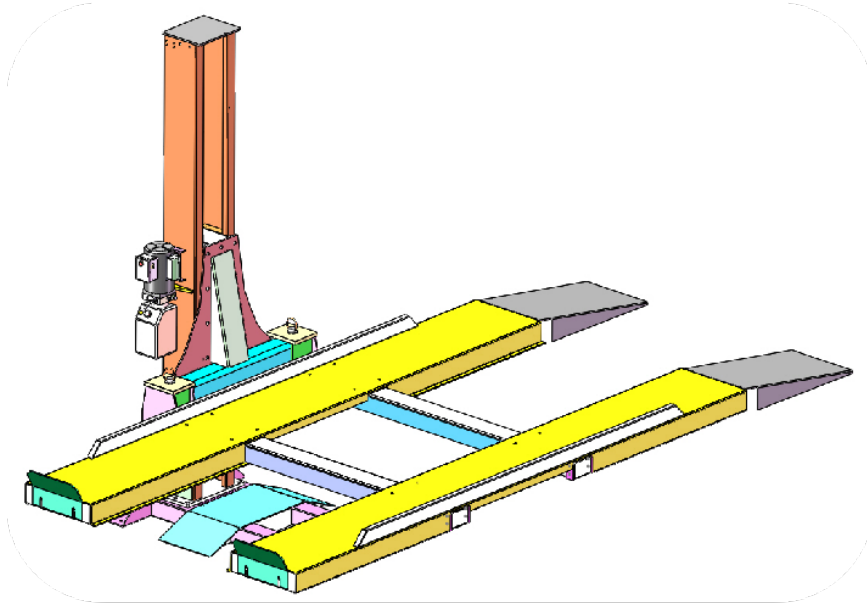

**Fig.1**

### **Single-post Parking Lift MODEL SPL-6**

- Specially designed for parking.
- Dual safety device, No air source, manual safety lock release
- Non slip lifting platform
- H-shaped lifting platform with reinforced column to provide excellent stability
- Available for low ceilings garage of less than 110" (2800mm).
- Suitable for home garages and commercial applications, with limited floor space.

### **MODEL SPL-6 SPECIFICATIONS**

<b>Model</b>	<b>Lifting Capacity</b>	<b>Lifting Height</b>	<b>Lifting Time</b>	<b>Overall Height</b>	<b>Overall Width</b>	<b>Outside Edge of Runways</b>	<b>Motor</b>
SPL-6	6,000 lbs	74" (1880mm)	84S (110V) 32S (220V)	108 7/8" (2766mm)	111" (2820mm)	82 3/8" (2093mm)	1.0HP(110V)/ 2.0HP(220V)

## II. INSTALLATION REQUIREMENT

### A. TOOLS REQUIRED

- ✓ Carpenter's Chalk



- ✓ Level Bar



- ✓ English Spanner(12")



- ✓ Pliers



- ✓ Wrench set: ((10#, 13#, 14#, 15#  
17#, 19#, 24#, 27#)



- Hammer



- ✓ Screw sets



- ✓ Tape Measure(7.5mm)



- ✓ Socket Head Wrench (4#, 5#, 6#)



- Rotary Hammer Drill ( $\Phi 3/4$ )



Fig.2

## B. STORAGE AND INSTALLATION REQUIREMENT

Keep or install the equipment in shaded, normal temperature, dry and ventilated environment.

### **SPECIFICATIONS OF CONCRETE** (See Fig. 3)

**Specifications of concrete must be adhered to the specification as following.**

**Failure to do so may result in lift and/or vehicle falling.**

1. Concrete must be thickness 5" (120mm) minimum and without reinforcing steel bars, and must be totally dry before lift installation.
2. Concrete must be in good condition and must be of test strength 3,500psi (245kg/cm<sup>2</sup>) minimum.
3. Floors must be level with no cracks or holes.

## C. POWER SUPPLY

The electrical source must be 3.0HP minimum. The source cable size must be 2.5mm<sup>2</sup>.

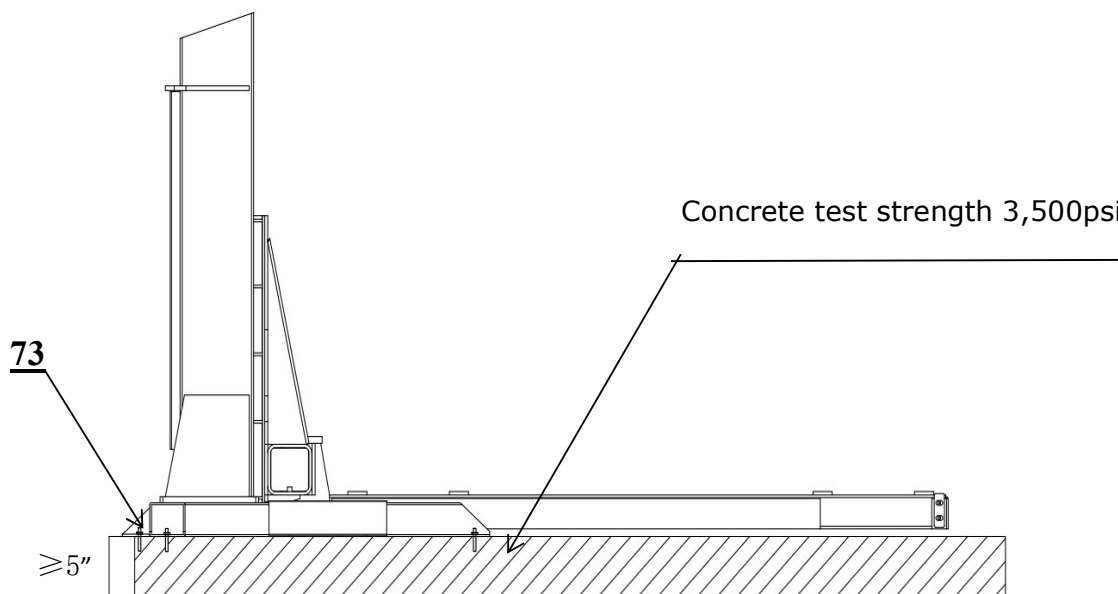

**Fig.3**

### III. STEPS OF INSTALLATION

#### A. Location of installation

Check and insure the installation location (concrete, layout, space size etc.) is suitable for lift installation.

#### B. Check the parts before assembly

1. Packaged lift and hydraulic power unit **(See Fig. 4)**

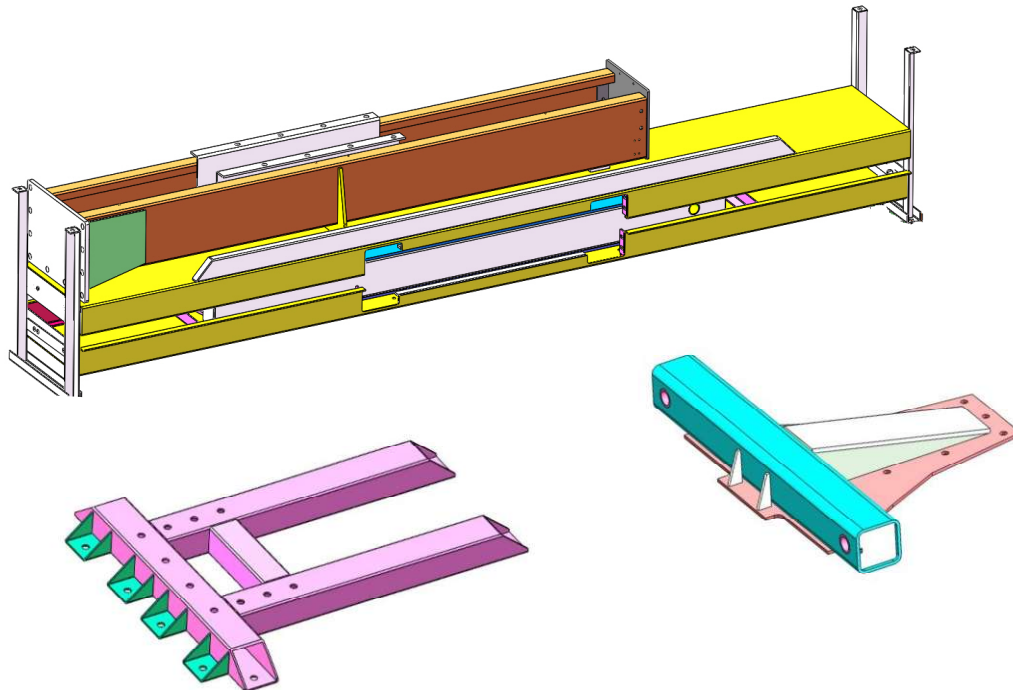

**Fig.4**

2. Take off the packaging on the machine ⇒ Take off the packing rack.

3. Move aside the parts and check the parts according to the shipment parts list **(See Fig.5 & 6)**

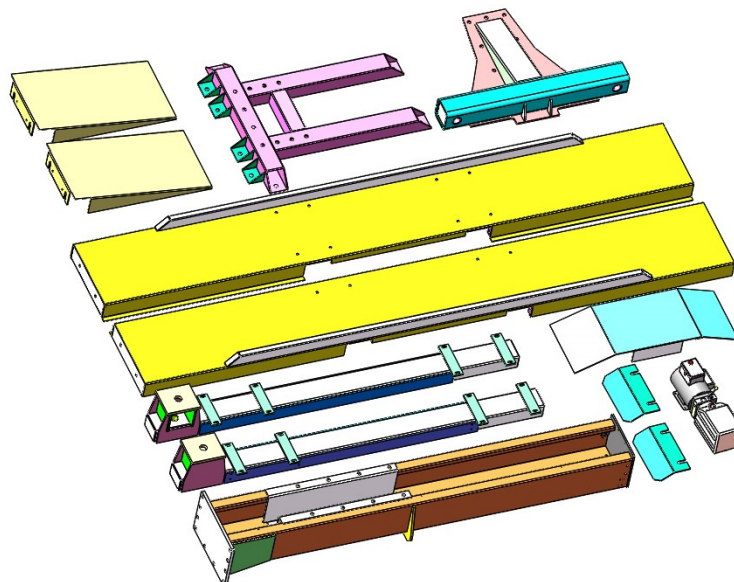

**Shipment list  
Fig.5**



**Parts Box (65)  
Fig.6**

4. Check the parts of the parts bag according to the parts bag list (See Fig. 7)

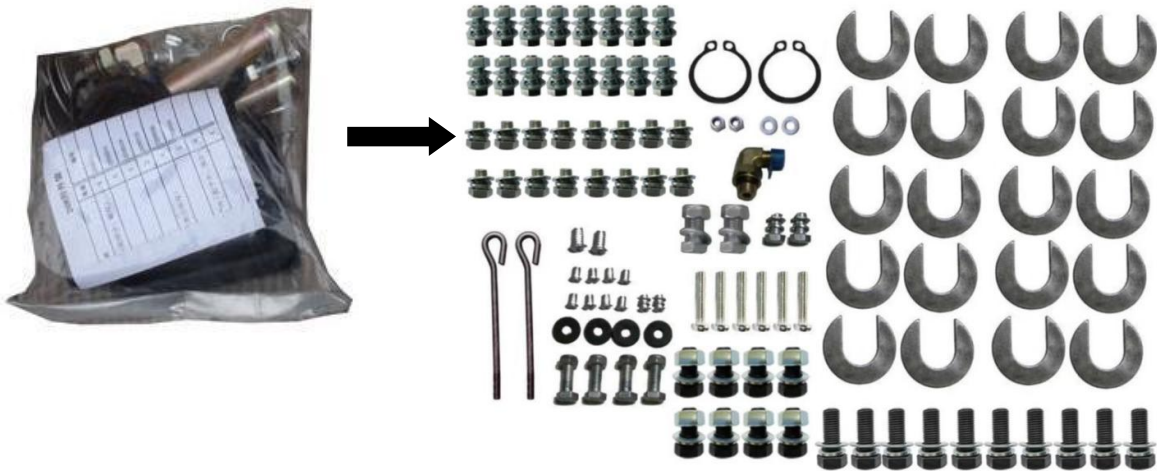

**Fig.7**

**C. Lay the base flat to the ground, confirm installation place according to the ground state, the main purpose is to save space. (See Fig.8)**

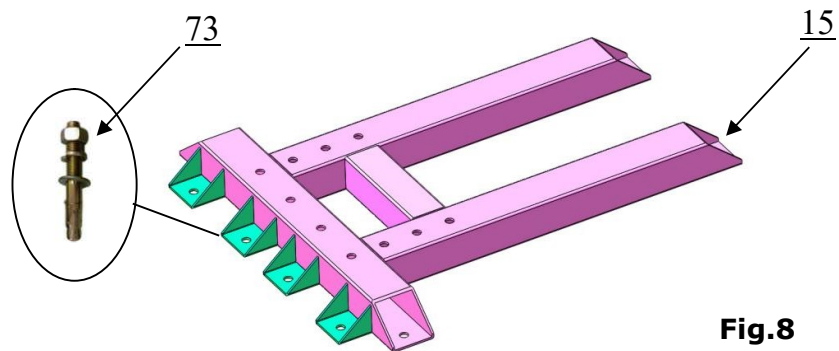
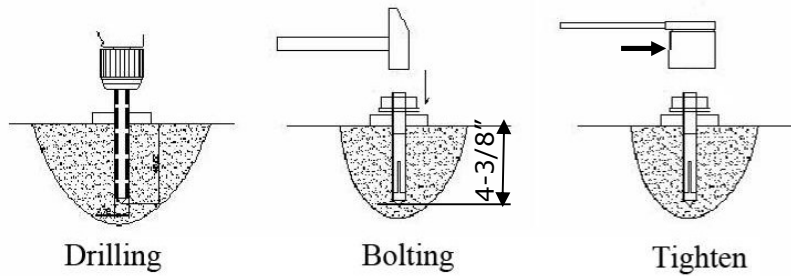

**Fig.8**

#### D. Fix anchor bolts

Using the prescribed rotary hammer drill, and drill all the anchor holes and install the anchor bolts. Then tighten the anchor bolts (**See Fig. 9**)

**Note:** Torque of Anchors is 150N.m .Minimum embedment of Anchors is 4-3/8".



**Fig.9**

#### E. Install column and lift platform

1.Lay the column flat to the ground. (See Fig.10)

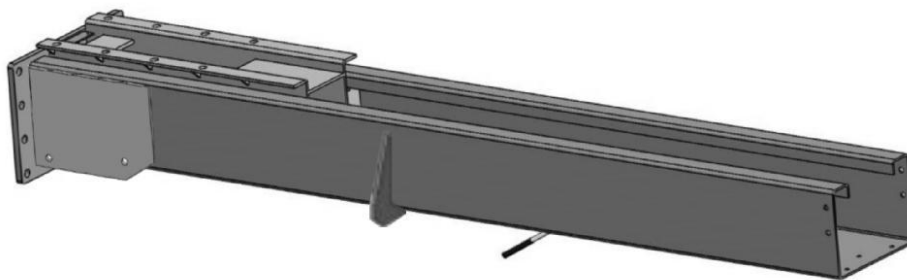

**Fig.10**

2.Connecting oil hose of cylinder. (See Fig.11)

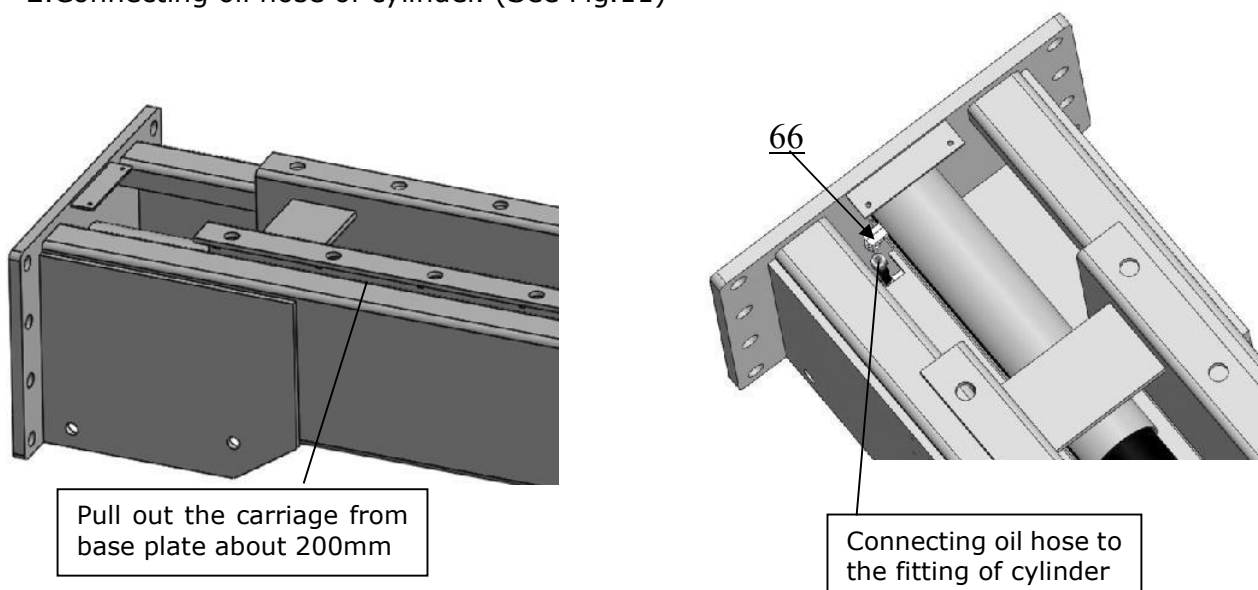

**Fig.11**



3. Fix column to the base plate. (See Fig.12)

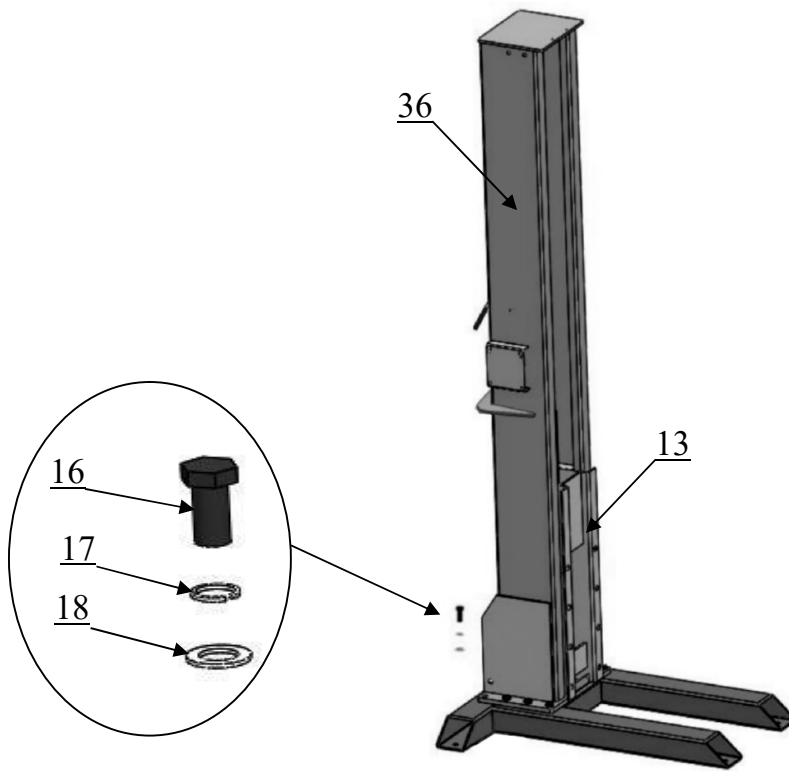

**Fig.12**

4. Install slider to the behind of lifting Platform (See Fig.13)

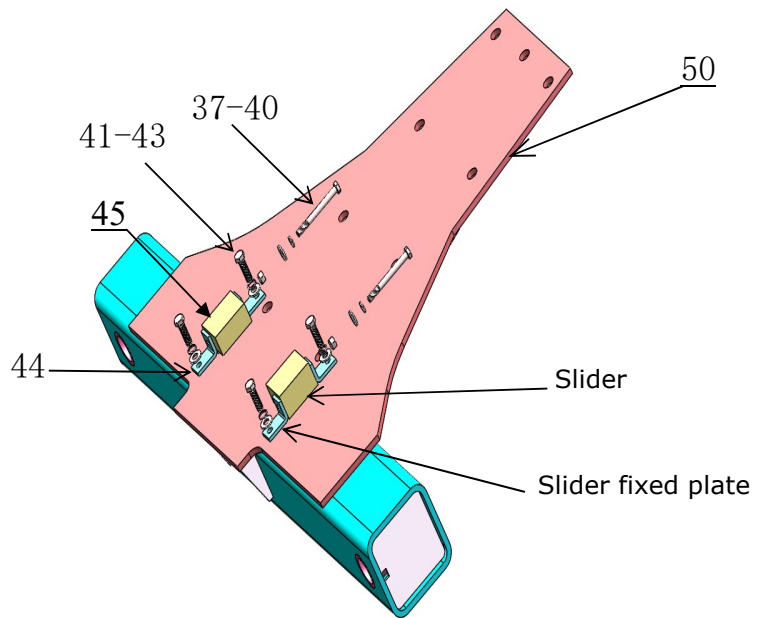

**Fig.13**

5. Fixed the lifting platform to the carriage(See Fig.14)

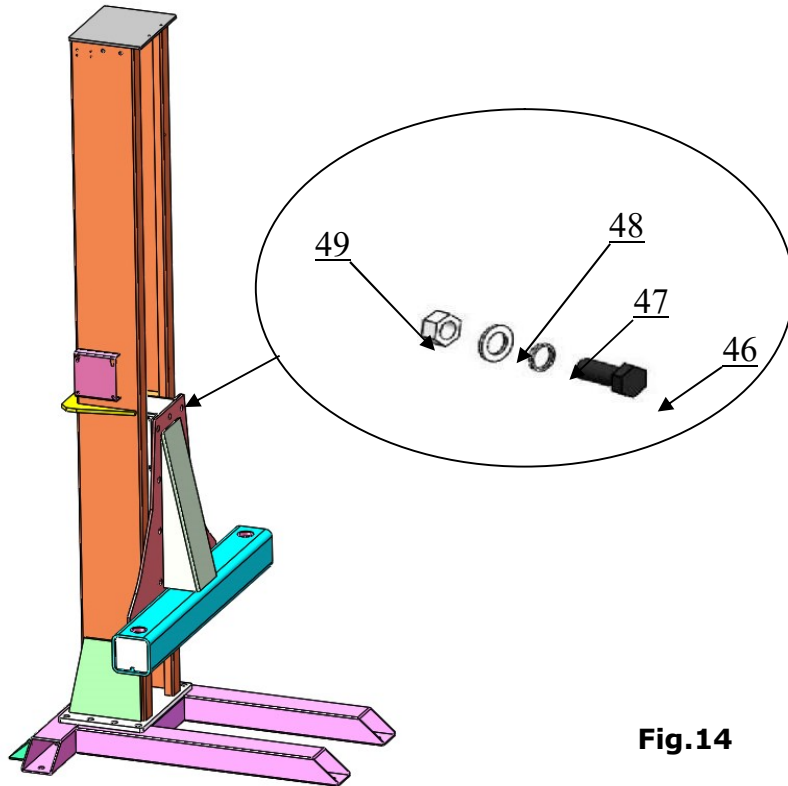
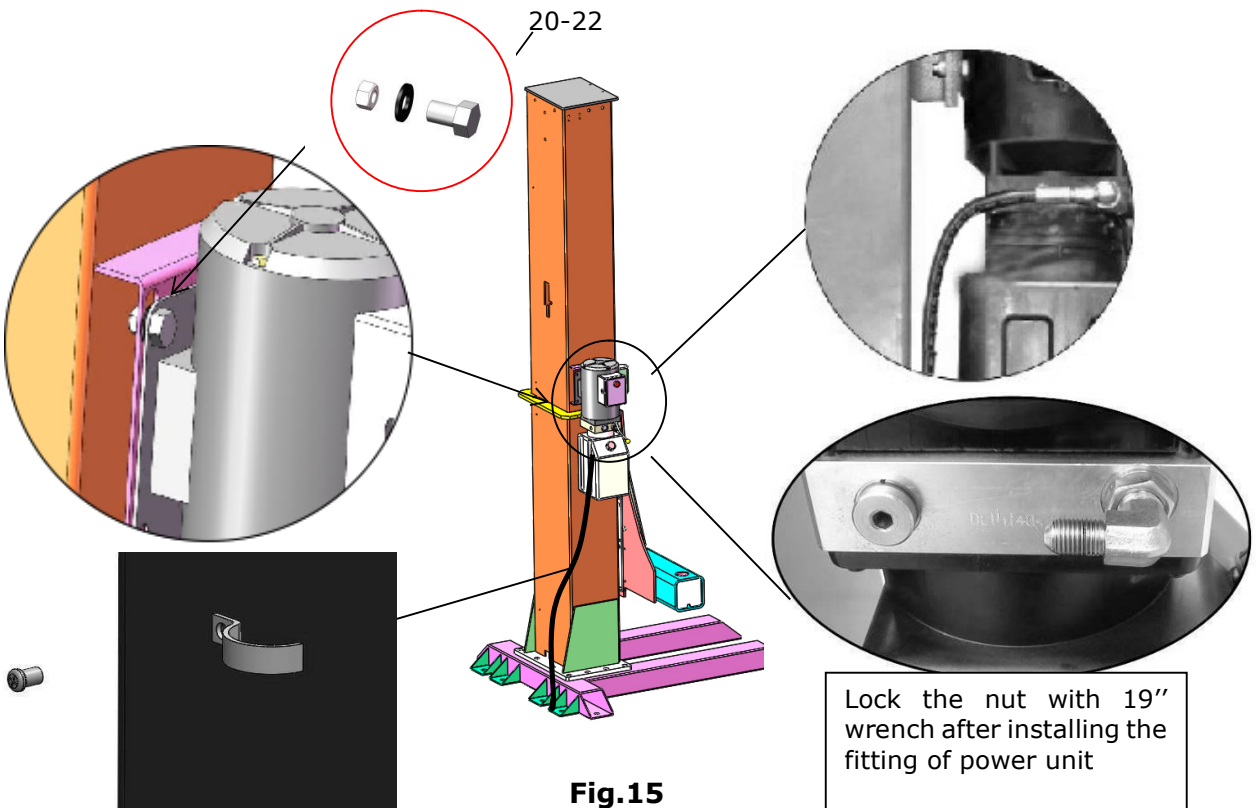

**Fig.14**

**E. Install power unit ,oil hoses and clip (See Fig.15)**

**Note: Tighten the oil hose fitting and power unit fitting to avoid oil leakage; Pay attention to the direction of power unit fitting.**

**Please use Hydraulic Oil 46#**



Lock the nut with 19" wrench after installing the fitting of power unit

**Fig.15**

### G. Install electrical system

Connect the power source on the data plate of power unit.

**Note: For the safety of operators, the power wiring must contact the earth well.**

#### Single phase motor

1. Power supply wires (active wire **L** and neutral wire **N**) to terminals of AC contactor marked L1, L3 respectively. Circuit diagram
2. Connecting the earth wire terminal of the motor.

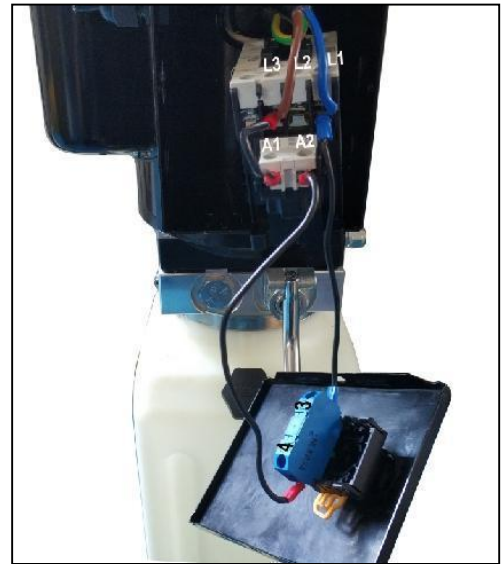
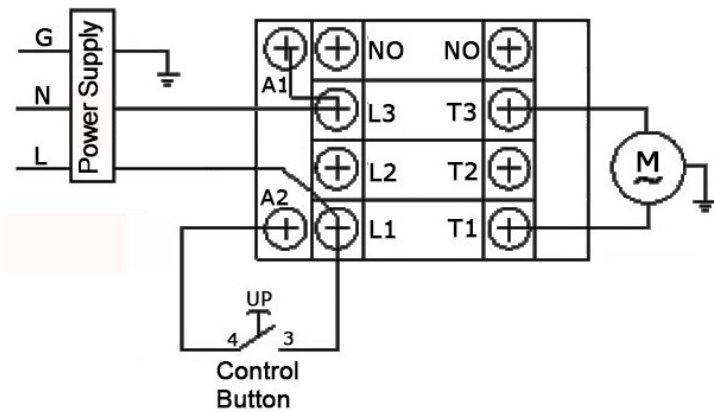

**Fig. 16**

### H. Install lifting arms

Lifting the carriages to the suitable position, and then joint the arm to the carriage, used the snap ring to limited the position after the PIN inserted completely and go though to bottom.

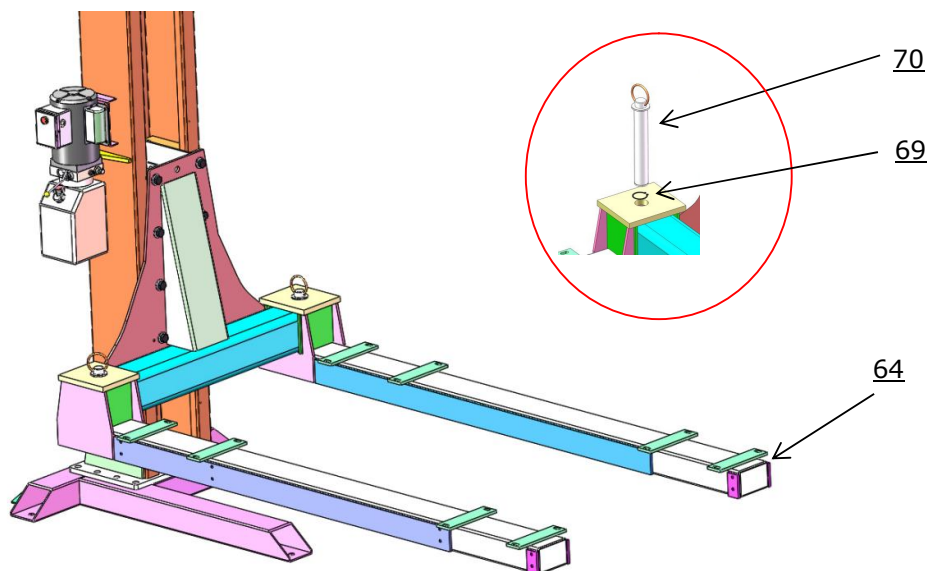

**Fig.17**

## I. Install wheel assembly

1. Lifting the arm to the suitable position, align the cut of the platform with the square tube of the arm and connect it with bolts(Wash can be add up and down side).Two platform can be transferred and installation randomly. Connecting the arm and platform after the 16 holes of platform are alignment. (**Fig.18**),

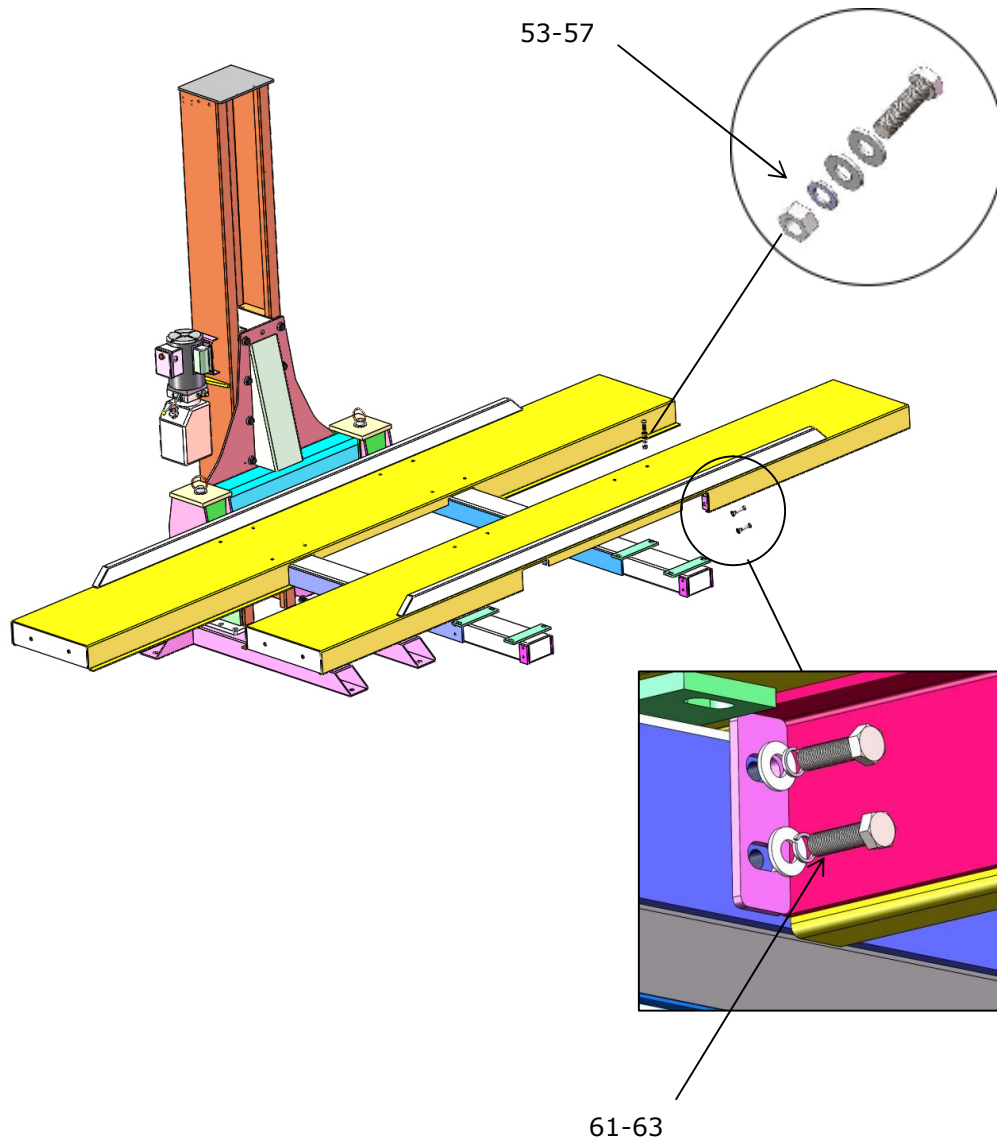

**Fig.18**

**J. Install the drive-in ramp, platform and the base guide plate (Fig.19):** After the top plate is fixed, the two sides of the drive-in ramp and guide plate are bolted on both sides of the top plate. The boarding guide plate is directly stuck in the middle of the base.

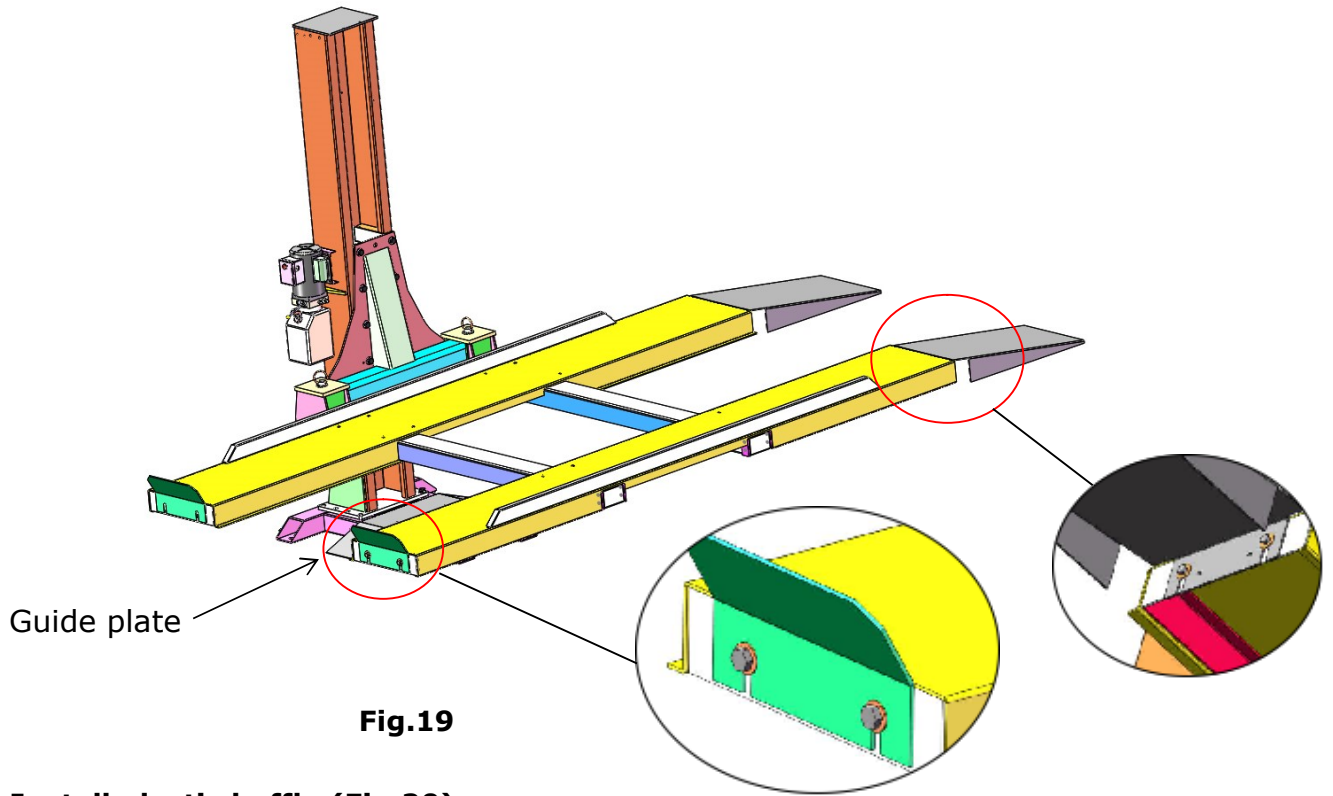

**Fig.19**

**K. Install plastic baffle (Fig.20)**

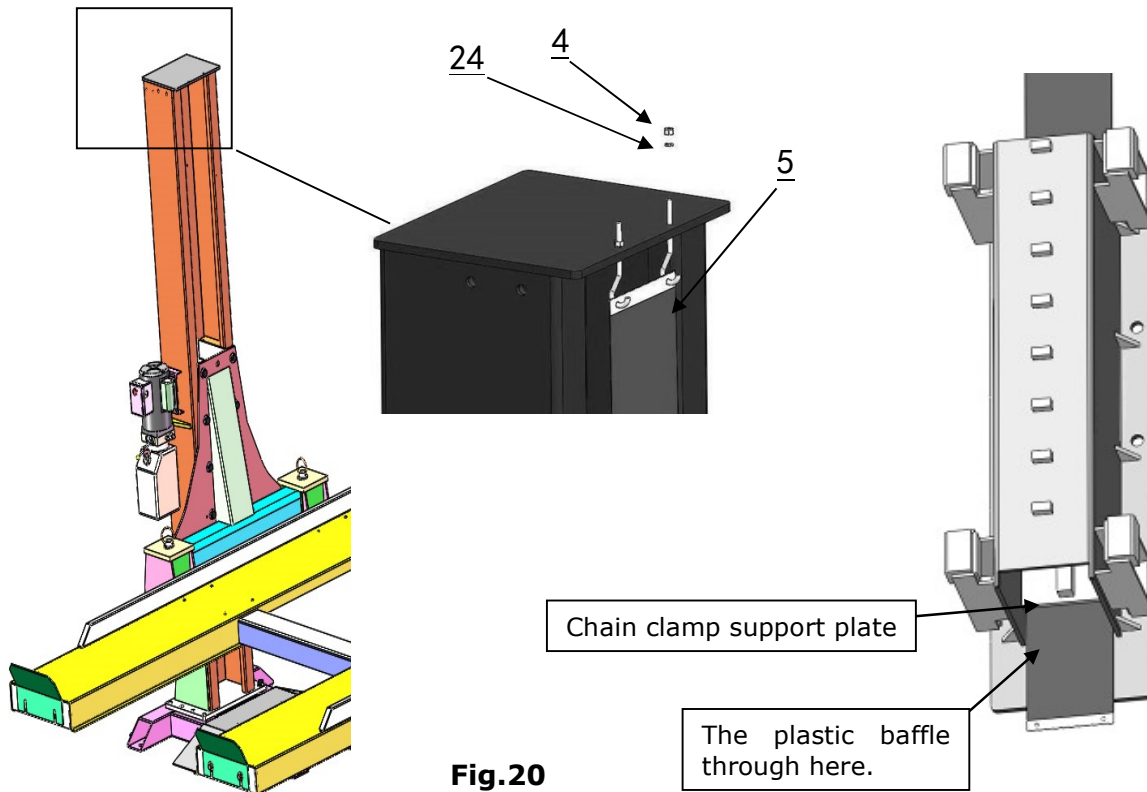

**Fig.20**

**L. Measure the vertical of the column with a horizontal ruler and correct the vertical of the column with a horizontal adjustment pad.(Fig.21)**

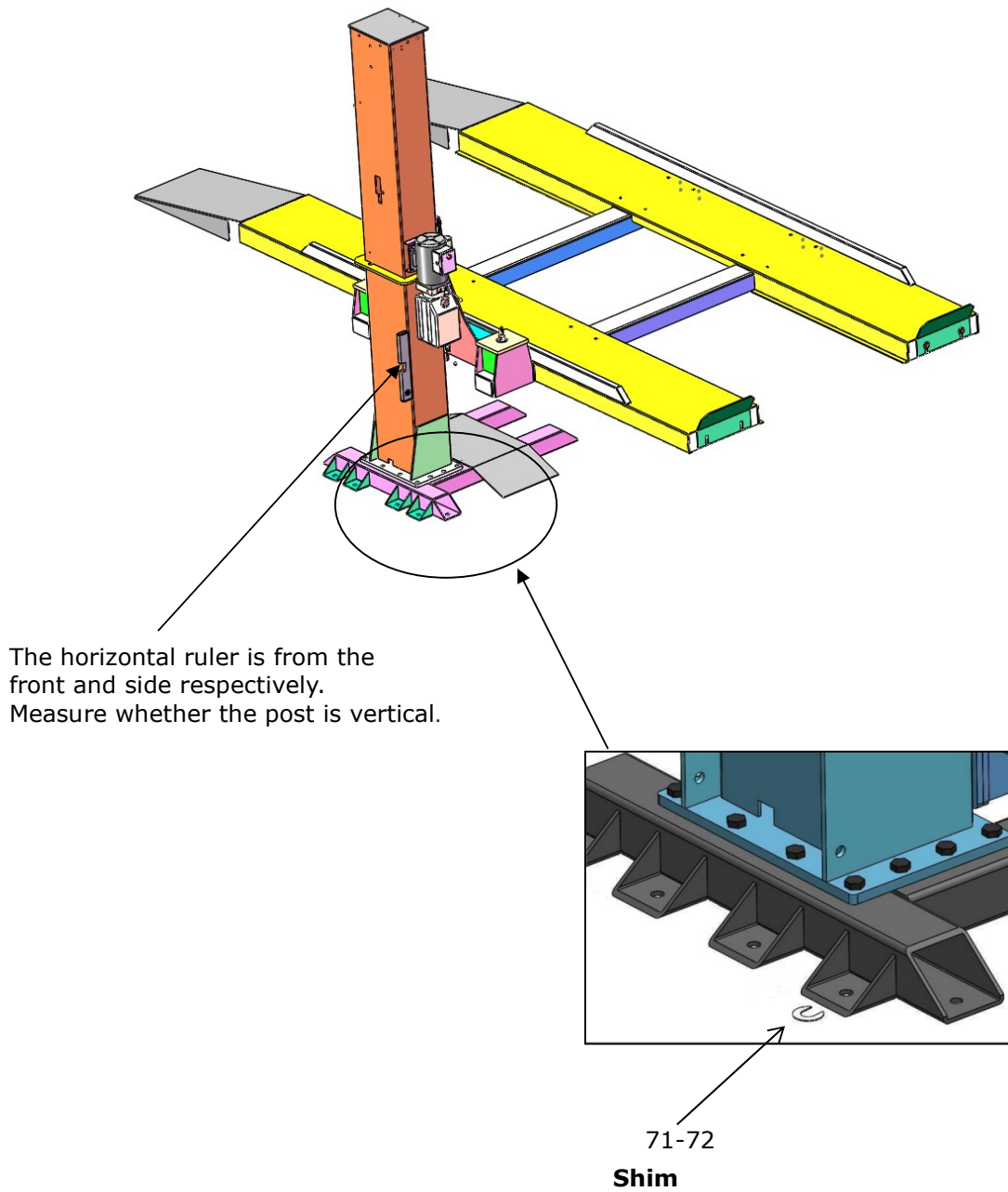

**Fig.21**

#### IV. EXPLODED VIEW

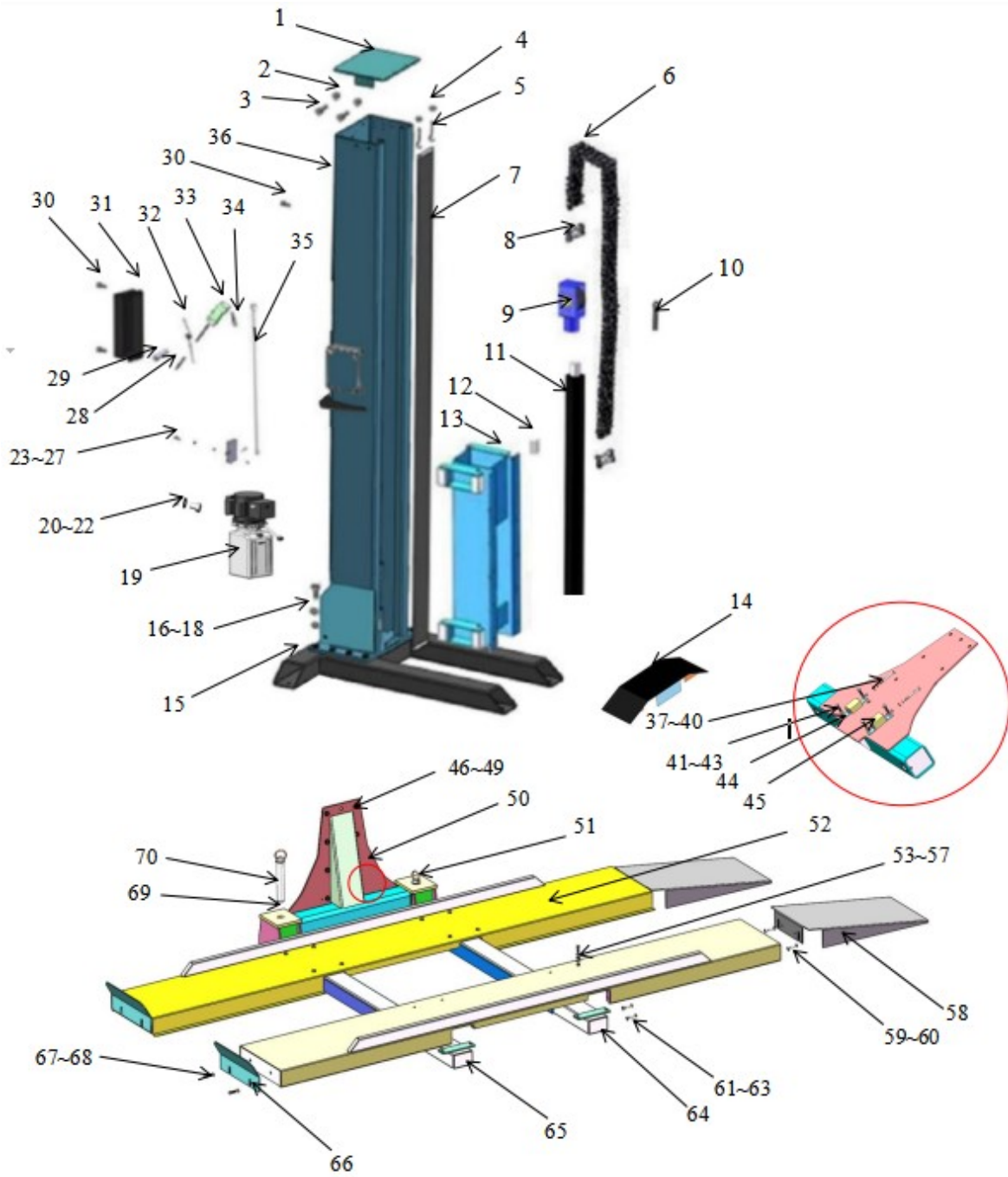

Fig.22

## PARTS LIST FOR SPL-6

Item	Part#	Description	QTY.	Note
1	101013	Platform	1	
2	10206023	Self-Locking Nut M12	4	
3	10217069	Hex Bolt M12*30	4	
4	10420018	Self-Locking Nut M6	3	
5	10203117	Hook adjusting screw M6*95	2	
6	10101007	Chain	1	
7	11101042	Curtain L=2570mm	1	
8	10201010A	Chain joint	2	
9	207681	Chain Pulley seat assy.	1	
10	10201005	Split pin(φ4*50)	1	
11	207010	Oil cylinder φ75*870mm	1	
12	10217188	Slider (46*46*76)	8	
13	1101082023A	Carriage	1	
14	1101082024A	Guidance plate	1	
15	101023	Base	1	
16	10101002	Hex Bolt M20*50	10	
17	10201114	Lock Washer φ20	10	
18	10209128	Washer φ20	10	
19	071103	Power unit 110V/60Hz	1/1	
	071104	Power unit 220V/60Hz		
20	10209003	Hex Bolt M8*25	4	
21	10209004	Rubber ring 8*20*3	4	
22	10209005	Self-Locking Nut M8	4	
23	10217013	Hex Bolt M6*20	1	
24	10209149	Lock washer φ6	5	
25	10420045	Washer φ6	13	
26	11203261	Safety lock block of power-side	1	
27	10420018	Self-Locking Nut M6	3	
28	10206003	Handle rubber sleeve	1	
29	11206002	Pin of safety lock block	1	
30	10209009	Cup Head Bolt M6*8	6	
31	11209008	Safety lock cover	1	
32	10209007	Spring	1	
33	11203263	Safety lock of power-side	1	
34	10209012	Spring Pin φ3.2	1	
35	11203013	Connecting bar	1	
36	101040	Column	1	
37	85090205	Socket Bolt M10*80	2	
38	10209039	Lock wash φ10	2	
39	10209022	Wash φ10	2	
40	10209021	Hex Bolt M10	2	
41	10209038	Hex Bolt M10*15	4	
42	10209039	Lock wash φ10	4	
43	10209022	Wash φ10	4	
44	1101082027	Slider fixed plate	4	
45	1001082002	Slider	2	
46	1001012001	Hex Bolt M20*40	8	



<b>Item</b>	<b>Part#</b>	<b>Description</b>	<b>QTY.</b>	<b>Note</b>
47	10201114	Lock wash φ20	8	
48	10209128	Wash φ20	8	
49	10420175A	Hex Nut M20	8	
50	1101082001A	Lifting platform	1	
51	10209153	Latch pull ring	2	
52	1101082013A	Platform	2	
53	10209127	Hex bolt M12*35	16	
54	10206006	Washer φ12	16	
55	10206006	Washer φ12	16	
56	10420026	Lock Washer φ12	16	
57	10206023B	Hex Nut M12	16	
58	11410640	Drive-in ramp	2	
59	10410013	Hex bolt M12*35	4	
60	10420029	Washer φ16	4	
61	41080184	Hex bolt M12*16	16	
62	10420026	Lock Washer φ12	16	
63	10206006	Washer φ12	16	
64	1101082003A	Left Arm	1	
65	1101082003A	Right Arm	1	
66	1101082018	Tyre stop plate	1	
67	10410013	Hex bolt M12*16	4	
68	10420029	Washer φ16	4	
69	10206033	Snap ring φ45	2	
70	1101082009A	Pin for arm	2	
71	10620065	Shim (2mm)	10	
72	10201090	Shim (1mm)	10	
73	10201140	Bolt 3/4"*6-1/2"	8	

## 1. Cylinder (10207010) Exploded View:

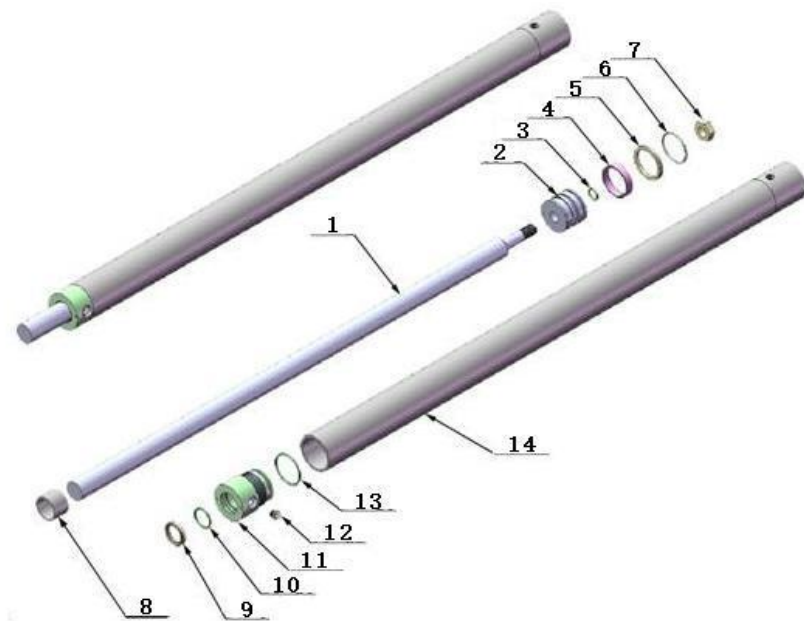
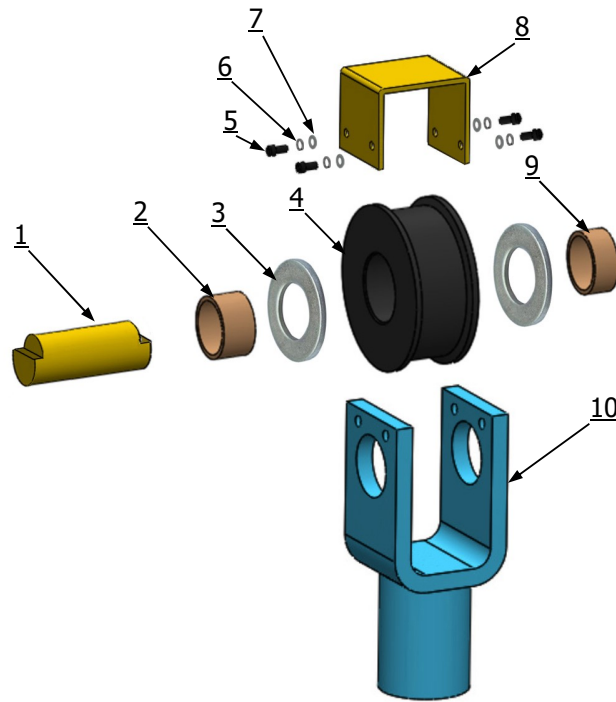

Fig. 23

Item	Part#	Description	QTY.	Note
1	11207027	Piston Rod	1	
2	11207028	Piston	1	
3	10206069	O-Ring	1	
4	10620053	Support Ring	1	
5	10620054	Y-Ring	1	
6	10630027	O-ring	1	
7	10206071	Hex Nut	1	
8	11207029	Piston rod adjusting sleeve	1	
9	10217078	Dust Ring	1	
10	10520058	O-Ring	1	
11	11207030	Head Cap	1	
12	10201034	Bleeding Plug	1	
13	10207031	O-Ring	1	
14	11207032	Cylinder Tube	1	

## 2. Chain Pulley Seat assy. (11207681)Exploded View:



**Fig.24**

Item	Part#	Description	QTY.
1	11207006	Pin for Chain Pulley $\Phi 35 \times 93$	1
2	10420132A	Bronze Bush $\Phi 41.2 \times \Phi 35.1 \times 20$	1
3	11530023	Washer $\Phi 44 \times \Phi 35.5 \times 2$	2
4	11207007	Chain Pulley $\Phi 105 \times 50$	1
5	10430138	Socket Bolt M6*16	4
6	10209149	Lock washer $\Phi 6$	4
7	10420045	Washer $\Phi 6$	4
8	11207693	Chain limit block	1
9	10530042	Bronze Bush $\Phi 41.2 \times \Phi 35.1 \times 28$	1
10	11207008	Chain Pulley Seat	1

### 3. Power Unit (071103) Exploded View:

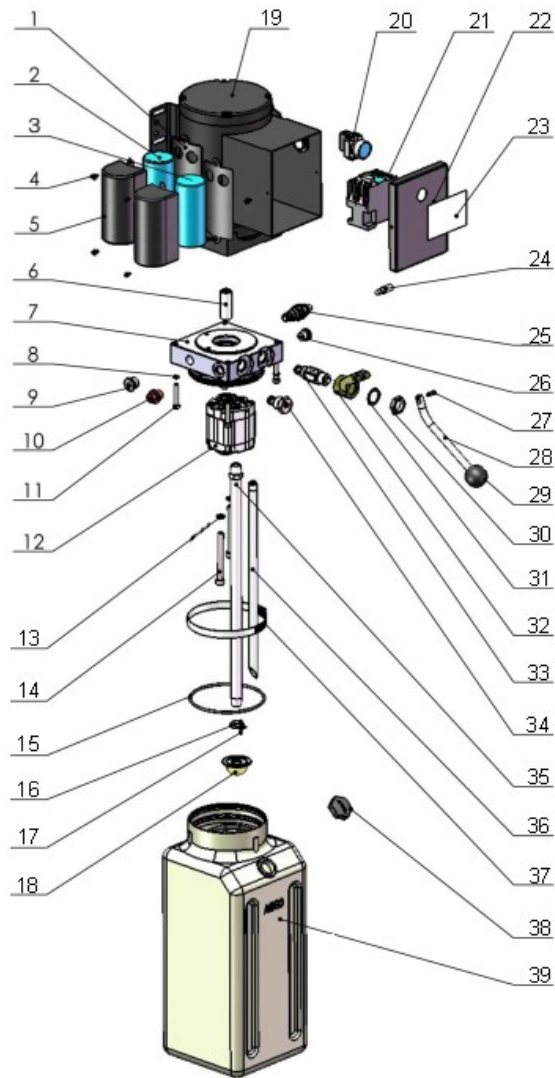

**110V/60HZ/1 Phase Manual**

**Fig. 25**

## PARTS LIST FOR MANUAL POWER UNIT (071103)

ITEM	Part#	Description	QTY.	Note
1	81400180	Rubber pad	2	
2	81400250	Start capacitor	1	
3	81400200	Run capacitor	1	
4	10420148	Cup Head Bolt with Washer	4	
5	81400066	Cover of capacitor	2	
6	81400363	Motor connecting shaft	1	
7	81400362	Manifold block	1	
8	10209149	Lock Wash	4	
9	81400276	Iron Plug	1	
10	81400259	Red plastic plug	1	
11	85090142	Socket Bolt	4	
12	81400312	Gear pump	1	
13	10209034	Lock Washer	2	
14	81400295	Socket bolt	2	
15	81400365	O ring	1	
16	10209152	Tie	1	
17	85090167	Magnet	1	
18	81400290	Filter	1	
19	81400412	Motor	1	
20	10420070	Push button	1	
21	81400559	AC connector	1	
22	81400287	Cover of Motor Terminal Box	1	
23	71111211	AMGO label	1	
24	81400560	Throttle valve	1	
25	81400266	Relief valve	1	
26	81400284	Iron Plug	1	
27	81400452	Pin	1	
28	81400451	Handle for release valve	1	
29	10209020	Plastic ball	1	
30	81400421	Nut for release valve	1	
31	81400422	Self-Locking Washer	1	
32	81400449	Valve seat(Low)	1	
33	81400567	Release valve	1	
34	81400566	Check valve	1	
35	81400375	Inlet pipe	1	
36	81400376	Oil return pipe	1	
37	81400364	Hose clamp	1	
38	81400263	Oil tank cap	1	
39	81400320	Oil tank	1	

## 8. Manual Power Unit (071104) Exploded View:

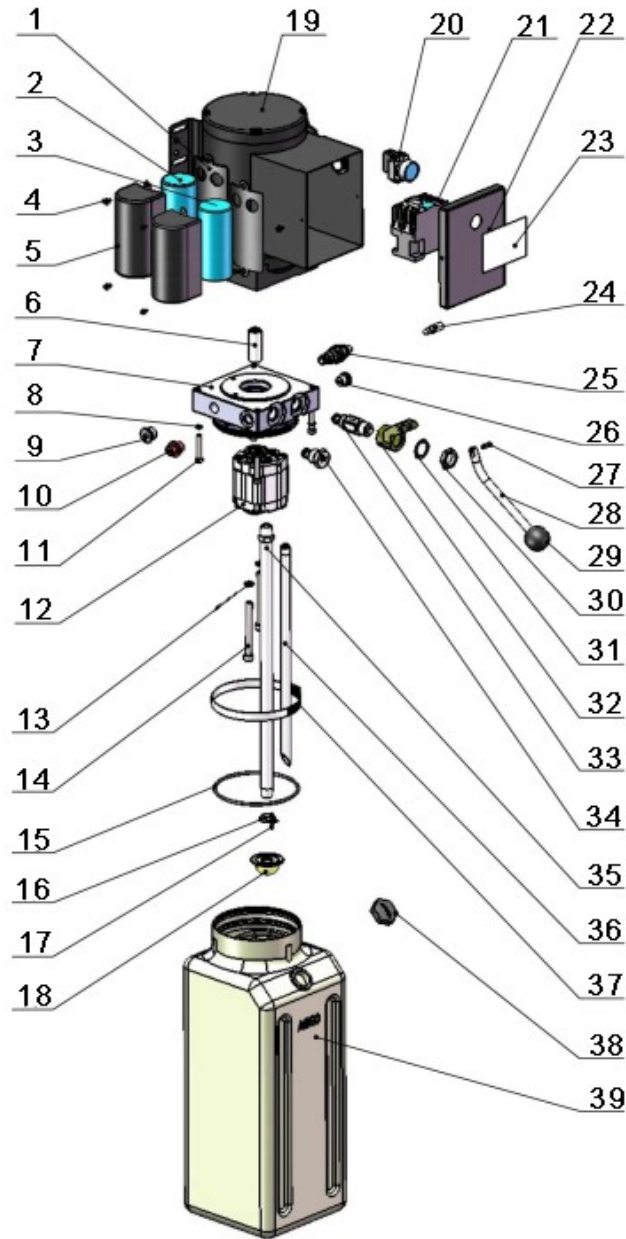

220V/60HZ/1 Phase Manual

Fig. 26

## PARTS LIST FOR MANUAL POWER UNIT (071104)

ITEM	Part#	Description	QTY.	Note
1	81400180	Rubber pad	2	
2	81400250	Start capacitor	1	
3	81400200	Run capacitor	1	
4	10420148	Cup Head Bolt with Washer	4	
5	81400066	Cover of capacitor	2	
6	81400363	Motor connecting shaft	1	
7	090101	Manifold block	1	
8	10209149	Lock Washer	4	
9	81400276	Iron Plug	1	
10	81400259	Red plastic plug	1	
11	85090142	Socket Bolt	4	
12	81400312	Gear pump	1	
13	10209034	Lock Washer	2	
14	81400295	Socket bolt	2	
15	81400365	O ring	1	
16	10209152	Tie	1	
17	85090167	Magnet	1	
18	81400290	Filter	1	
19	81400413	Motor	1	
20	10420070	Push button	1	
21	41030055	AC connector	1	
22	81400287	Cover of Motor Terminal Box	1	
23	71111104	Name plate	1	
24	81400560	Throttle valve	1	
25	81400266	Relief valve	1	
26	81400284	Iron Plug	1	
27	10720118	Pin	1	
28	81400451	Handle for release valve	1	
29	10209020	Plastic ball	1	
30	81400421	Nut for release valve	1	
31	81400422	Self-Locking Washer	1	
32	81400449	Valve seat(Low)	1	
33	81400567	Release valve	1	
34	81400566	Check valve	1	
35	81400375	Oil Inlet pipe	1	
36	81400376	Oil return pipe	1	
37	81400364	Hose clamp	1	
38	81400263	Oil tank cap	1	
39	81400320	Oil tank	1	

## Illustration of hydraulic

### Valve for hydraulic power unit

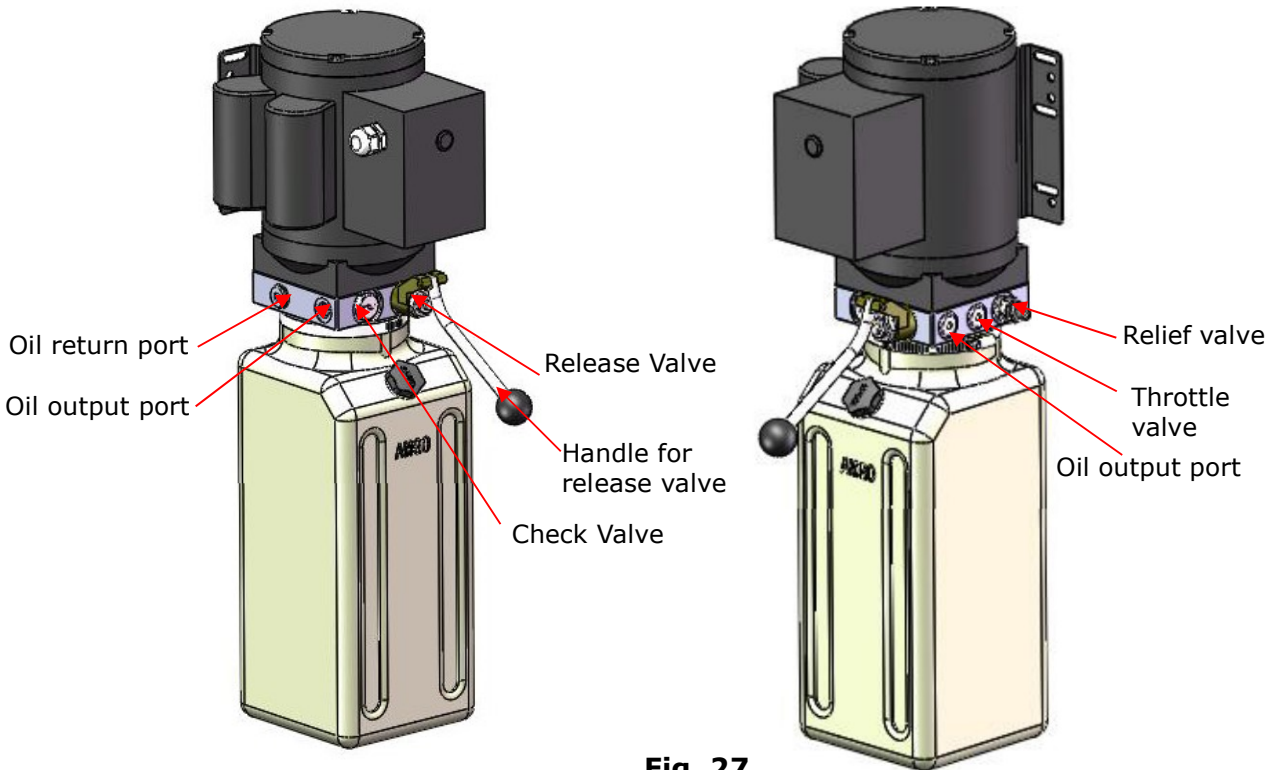

Fig. 27

## V. TEST RUN

### 1. Adjust the lower speed (Fig.28)

You can adjust the lower speed of the lift if needing: Turn the Throttle Valve in clockwise direction to decrease the lower speed, or increase the speed in counterclockwise direction.

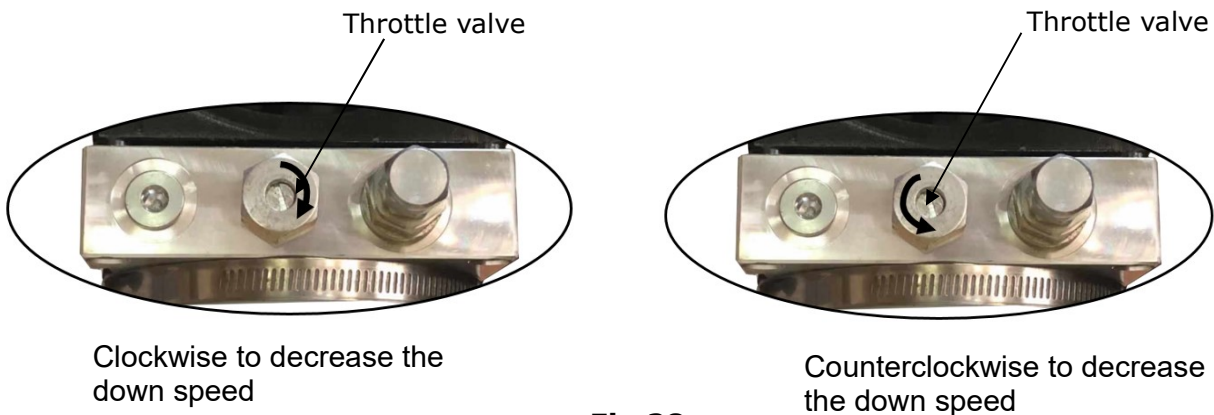

Fig.28



## 2. Test with load

After finishing the above adjustment, test running the lift with load. Lift the lift in low position for several times first, make sure the lift can rise and lower without improper. And then test run the lift to top position completely. If there are anything improper, repeat the above adjustment.

**NOTE: It may be vibrated when lifting at start, please lifting it with load for several times, the air would be bled and the vibration would be disappeared automatically.**

### Circuit Diagram of Hydraulic System

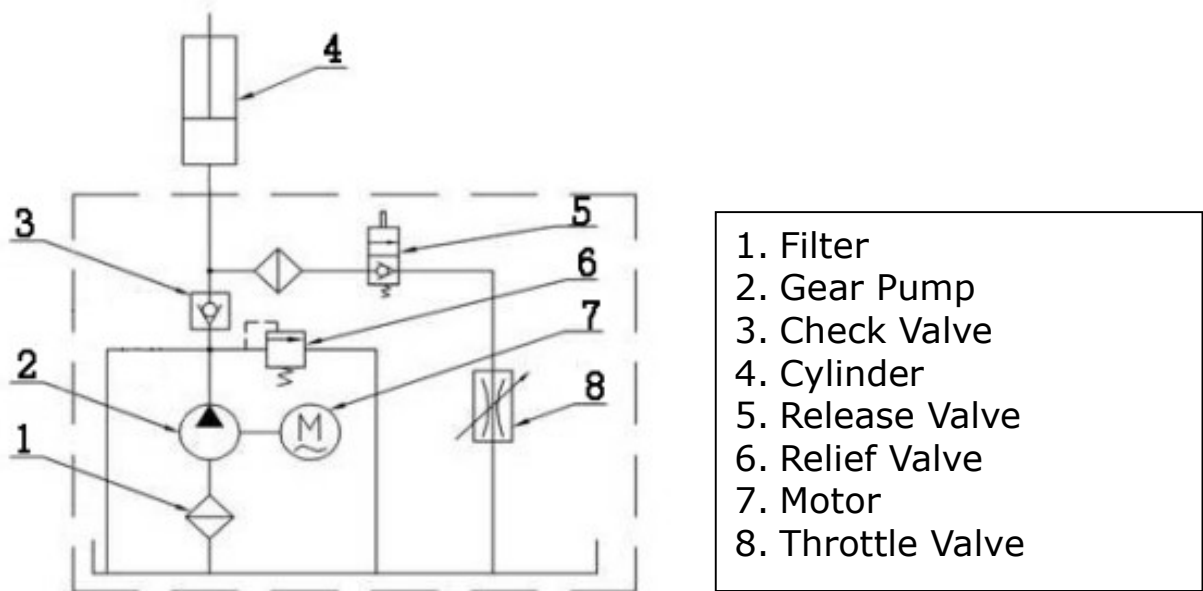

Fig.29

## **VI. OPERATION INSTRUCTIONS**

### **To lift vehicle**

1. Keep clean of site near the lift;
2. Position lift arms to the lowest position;
3. To shortest lift arms;
4. Open lift arms;
5. Position vehicle beside of the lifting arm, car should at the other side of the column;
6. Move arms to the vehicle's lifting point;

**Note: The four lift arms must at the same time contact the vehicle's lifting point where manufacturers recommended**

7. Turn on the power of the power unit and press **up** button until the rubber pads fully contact the car, making sure it is safe;
8. Slowly lift the lift. Make sure that the car is in a balanced state, then lift the car to the required height and release the **UP** button
9. Press the release handle of the power unit and lower the lift to the safety lock position. Only after confirming that the safety device is in a normal working state then the car can be maintained.

### **To lower vehicle**

1. Be sure the clearance of around and under the lift, only leaving operator in lift area;
2. Press the start button of the power unit to raise the vehicle slightly, and then open the safety device, then lower the vehicle by pressing the release handle of the power unit;
3. Open the arms and position them to the shortest length;
4. Drive away the vehicle.

## **VII.MAINTENANCE SCHEDULE**

Monthly:

1. Check all connectors, bolts and pins to insure proper mounting;
2. Lubricate cable with lubricant;
3. Make a visual inspection of all hydraulic hoses/lines for possible wear or leakage;
4. Check Safety device and make sure proper condition;
5. Lubricate all Rollers and Pins with 90wt. Gear oil or equivalent;

### **Every six months:**

1. Make a visual inspection of all moving parts for possible wear, interference or damage.
2. Check and adjust as necessary, equalizer tension of the cables to insure level lifting.
3. Check the vertical of columns.
4. Check Rubber Pads and replace as necessary.
5. Check Safety device and make sure proper condition.

### **Oil cylinder maintenance:**

In order to extend the service life of the oil cylinder, please operate according to the following requirements.

1. Recommend to use N46 anti-wear hydraulic oil.
2. The hydraulic oil of the lifts should be replaced regularly during using. Replace the hydraulic oil 3 months after the first installation, Replace the hydraulic oil once a year afterwards.
3. Make at least one full trip raising and lowering per day. For exhausting the air from the system, which could effectively avoid the corrosion of the cylinder and damage to the seals caused by presence of air or water in the system.
4. Protect the outer surface of the oil cylinder's piston rod from bumping and scratching, and timely clean up the debris on the oil cylinder dust-ring and the piston rod.

## VIII. TROUBLE SHOOTING

TROUBLE	CAUSE	REMEDY
Motor does not run	<ol style="list-style-type: none"> <li>1. Button does not work</li> <li>2. Wiring connections are not in good condition</li> <li>3. AC contactor burned out</li> <li>4. Motor burned out</li> </ol>	<ol style="list-style-type: none"> <li>1. Replace button</li> <li>2. Repair all wiring connection</li> <li>3. Repair or replace contactor</li> <li>4. Repair or replace motor</li> </ol>
Motor runs but the lift is not raised	<ol style="list-style-type: none"> <li>1. Motor runs in reverse rotation</li> <li>2. Release valve in damage</li> <li>3. Gear pump in damage</li> <li>4. Relief valve or check valve in damage</li> <li>5. Low oil level</li> </ol>	<ol style="list-style-type: none"> <li>1. Reverse two power wire</li> <li>2. Repair or replace</li> <li>3. Repair or replace</li> <li>4. Repair or replace</li> <li>5. Fill tank</li> </ol>
Lift does not stay up	<ol style="list-style-type: none"> <li>1. Release valve out of work</li> <li>2. Relief valve or check valve leakage.</li> <li>3. Cylinder or fittings leaks</li> </ol>	Repair or replace
Lift raises too slow	<ol style="list-style-type: none"> <li>1. Oil line is jammed</li> <li>2. Motor running on low voltage</li> <li>3. Oil mixed with air</li> <li>4. Gear Pump leaks</li> <li>5. Overload lifting</li> </ol>	<ol style="list-style-type: none"> <li>1. Clean the oil line</li> <li>2. Check Electrical System</li> <li>3. Fill tank</li> <li>4. Replace Pump</li> <li>5. Check load</li> </ol>
Lift cannot lower	<ol style="list-style-type: none"> <li>1. Safety device are locking</li> <li>2. Release valve in damage</li> <li>3. Safety cable broken</li> <li>4. Oil system is jammed</li> <li>5. Hydraulic solenoid valve out of work</li> </ol>	<ol style="list-style-type: none"> <li>1. Release the safeties</li> <li>2. Repair or replace</li> <li>3. Replace</li> <li>4. Clean the oil system</li> <li>5. Replace the solenoid valve</li> </ol>

## IX. Lift disposal.

When the car lift cannot meet the requirements for normal use and needs to be disposed, it should follow local laws and regulations.



**Address:** 1931 Jo Rogers Blvd, Manning, South Carolina, USA

**No:** 72210501

**Date:** 2022/10