

MaxJax™ Portable Mid-Rise Lift

Operation and Maintenance Manual

Manual P/N 5900268 — Manual Revision A5 — February 2023

Model:

- M7K



Original Instructions
in the English
Language

US Design Patent No. 8.256.577 B2
US Design Patent No. 9.150.395 B2

Designed and engineered by BendPak Inc. in Southern California, USA. Made in China.

 **DANGER**

IMPORTANT SAFETY INSTRUCTIONS, SAVE THESE INSTRUCTIONS! Read this entire manual thoroughly before installing, operating, servicing or maintaining this Lift. Failure to follow the instructions and safety precautions in this manual can result in serious injury or death. Make sure all other operators also read this manual. Keep the manual near the product for future reference. ***By proceeding with setup and operation, you agree that you fully understand the contents of this manual and assume full responsibility for product use.***

Manual. MaxJax™ Portable Mid-Rise Lift, *Operation and Maintenance Manual*, Manual Part Number 5900268, Manual Revision A5, Released February 2023.

Copyright. Copyright © 2023 by BendPak Inc. All rights reserved. You may make copies of this document if you agree that: you will give full attribution to BendPak Inc., you will not make changes to the content, you do not gain any rights to this content, and you will not use the copies for commercial purposes.

Trademarks. MaxJax, the MaxJax logo, BendPak, and the BendPak logo are registered trademarks of BendPak Inc. All other company, product, and service names are used for identification only. All trademarks and registered trademarks mentioned in this manual are the property of their respective owners.

Limitations. Every effort has been made to ensure complete and accurate instructions are included in this manual. However, product updates, revisions, and/or changes may have occurred since this manual was published. BendPak reserves the right to change any information in this manual without incurring any obligation for equipment previously or subsequently sold. BendPak is not responsible for typographical errors in this manual. You can always find the latest version of the **Operation and Maintenance Manual for your product on the MaxJax website.**

Warranty. The MaxJax warranty is more than a commitment to you: it is also a commitment to the value of your new product. Contact your nearest BendPak dealer or visit www.maxjax.com/warranty for full warranty details.

Safety. Your product was designed and manufactured with safety in mind. However, your safety also depends on proper training and thoughtful operation. Do not install, operate, maintain, or repair the unit without reading and understanding this manual and the labels on the unit; **do not use your Lift unless you can do so safely!**

Owner Responsibility. In order to ensure operator safety and maintain your product properly, it is the responsibility of the product owner to read and follow these instructions:



- Follow all setup, operation, and maintenance instructions.
- Make sure product setup and use conforms to all applicable local, state, and federal codes, rules, and regulations, such as state and federal OSHA regulations and electrical codes.
- Read and follow all safety instructions. Keep them readily available for operators.
- Make sure all operators are properly trained, know how to safely operate the unit, and are properly supervised.
- Do not operate the product until you are certain all parts are in place and operating correctly.
- Carefully inspect the product on a regular basis and perform all maintenance as specified.
- Service and maintain the unit only with approved replacement parts.
- Keep all instructions permanently with the product and make sure all labels are clean and visible.
- MaxJax makes no promises, guarantees or assurances that our products meet any state, county, federal or international mandated permit, license, code, standard, certification, or any other mandate other than what is listed or shown on MaxJax website(s), or any MaxJax or Dannmar or BendPak online or published catalog. Not all MaxJax lift models meet the standards as prescribed by ANSI/ALI ALCTV-(current edition) or ANSI/UL 201. Consult www.autolift.org for a complete list of lift models that meet ANSI/ALI ALCTV-(current edition) or ANSI/UL 201, or contact MaxJax via maxjax.com/support. Buyer assumes full responsibility for any state, county, federal or international mandated permit, license, code, standard, certification, or any other mandate required related to the installation and/or operation of any MaxJax, Dannmar or BendPak product. MaxJax, Dannmar, Ranger and BENDPAK will not be responsible for any charges, fines, liens, or other levies imposed on the Buyer related to any special or regional structural, seismic or any other building code and/or codes such as the Uniform Building Code (UBC), International Building Code (IBC), or any other state, county, federal or international mandated permit, license, code, standard, certification, or other mandate, law, rule, regulation or directive by any other agency, government, administrations, or corporations whether state, county, federal, or international mandated.
- **Only use the Lift if it can be used safely!**

Unit Information. Enter the Model Number, Serial Number, and the Date of Manufacture from the label on your unit. This information is required for part or warranty issues.

Model: _____

Serial: _____

Date of Manufacture: _____

MAXJAX <small>MaxJax is a wholly-owned subsidiary of BengPak, Inc.</small>		1645 Lemonwood Drive Santa Paula, CA USA www.MaxJax.com	
MODEL NUMBER			
DESCRIPTION			
LIFT CAPACITY		DATE CODE	
VOLTAGE		SERIAL NUMBER	
<input type="checkbox"/> 110-120V, 50-60 Hz, 1 Ph <input type="checkbox"/> 208-240V, 50-60 Hz, 1 Ph			
		UPC	
 DANGER! Disconnect Power Before Servicing			
MADE IN CHINA		WARRANTY VOID IF DATA PLATE IS REMOVED	
		PN 5906036	

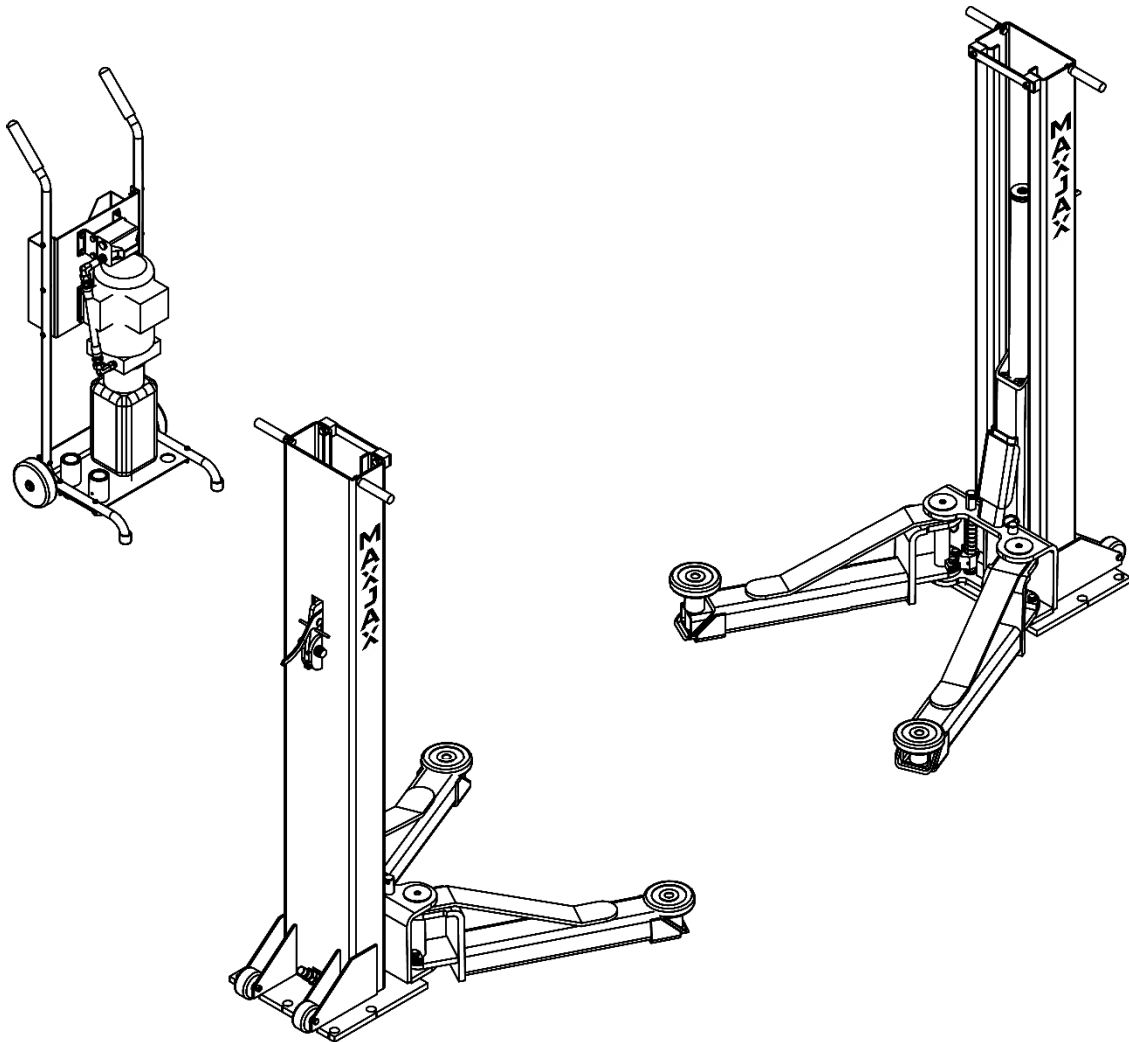

Table of Contents

Introduction	4	Troubleshooting	21
Shipping Information	4	Labels	22
Safety Considerations	5	Part Drawings	24
Specifications	8	ALI Store	29
Operation	9	Maintenance Log	30
Maintenance	20		

Introduction

MaxJax is a portable Mid-Rise Lift with a small footprint designed for low-ceiling garages. MaxJax can raise Vehicles up to 7,000 lbs. (3,175 kg). CE Approved when installed with the CE Safety Release Kit.

This manual is mandatory reading for all MaxJax users, including anyone who sets up, operates, maintains, or repairs them. Keep this manual on or near the device so that anyone who uses or services it can read it.

⚠ DANGER Be very careful when setting up, operating, maintaining, or repairing this equipment; failure to do so could result in property damage, product damage, injury, or (in very rare cases) death. Make sure only authorized personnel operate this equipment. Do not make modifications to the unit; this voids the warranty and increases the chances of injury or property damage. Make sure to read and follow the instructions on the labels on the unit.

If you are having issues, refer to the **Troubleshooting** section of this manual for assistance.

Technical support and service is available from your dealer, on the Web at maxjax.com/support, by email at support@maxjax.com, or by phone at **(844) 629-5291**.

Shipping Information

Your equipment was carefully checked before shipping. Nevertheless, you should thoroughly inspect the shipment **before** you sign to acknowledge that you received it.

When you sign the bill of lading, it tells the carrier that the items on the invoice were received in good condition. ***Do not sign the bill of lading until after you have inspected the shipment.*** If any of the items listed on the bill of lading are missing or damaged, do not accept the shipment until the carrier makes a notation on the bill of lading that lists the missing and/or damaged goods.

If you discover missing or damaged goods **after** you receive the shipment and have signed the bill of lading, notify the carrier at once and request the carrier to make an inspection. If the carrier will not make an inspection, prepare a signed statement to the effect that you have notified the carrier (on a specific date) and that the carrier has failed to comply with your request.

It is difficult to collect for loss or damage after you have given the carrier a signed bill of lading. If this happens to you, file a claim with the carrier promptly. Support your claim with copies of the bill of

loading, freight bill, invoice, and photographs. Our willingness to assist in helping you process your claim does not make us responsible for collection of claims or replacement of lost or damaged materials.

Safety Considerations

Read this entire manual thoroughly before installing, operating, servicing or maintaining this Lift. Do not install or operate the product until you are familiar with all operating instructions and warnings. Do not allow anyone else to operate it until they are familiar with all operating instructions and warnings.

 **WARNING** **California Proposition 65.** This product can expose you to chemicals including styrene and vinyl chloride which are on the list of over 900 chemicals identified by the State of California to cause cancer, birth defects, or other reproductive harm. Always use this product in accordance with BendPak Danmark's instructions. For more information, visit www.p65warnings.ca.gov.

IMPORTANT SAFETY INSTRUCTIONS!

SAVE THESE INSTRUCTIONS!

1. Read all instructions.
2. Care must be taken as burns can occur from touching hot parts.
3. Do not operate equipment with a damaged cord or if the equipment has been dropped or damaged – until it has been examined by a qualified service person.
4. Do not let a cord hang over the edge of a table, bench, or counter or come in contact with hot manifolds or moving fan blades.
5. If an extension cord is necessary, a cord with a current rating equal to or more than that of the equipment should be used. Cords with a current rating less than the equipment may overheat. Care should be taken to arrange the cord so that it will not be tripped over or pulled.
6. Always unplug the equipment from the electrical outlet when not in use. Never use the cord to pull the plug from the outlet. Grasp the plug and pull to disconnect.
7. Let the equipment cool completely before putting away. Loop cord loosely around equipment when storing.
8. To reduce the risk of fire, do not operate in the vicinity of open containers of flammable liquids (gasoline).
9. Adequate ventilation should be provided when working on operating internal combustion engines.
10. Keep hair, loose clothing, fingers, and all parts of body away from moving parts.
11. To reduce the risk of electric shock, do not use on wet surfaces or expose to rain.
12. Use only as described in this manual. Use only BendPak recommended attachments.
13. ALWAYS WEAR SAFETY GLASSES. Everyday eyeglasses only have impact resistant lenses, they are not safety glasses.
14. To reduce the risk of injury, close supervision is necessary when this product will be used around children.
15. To reduce the risk of injury, **never** attempt to lift more than the rated capacity. Refer to loading instructions.

-
16. The Lift uses electrical energy; if your organization has Lockout/Tagout policies, make sure to implement them after connecting the Lift to a power source.
 17. Refer to markings for proper load on electrical receptacles.
 18. Only operate your Lift between temperatures of +41°F to +104°F (+5°C to +40°C).
 19. The Lift should **only** be operated by authorized personnel. Keep children and untrained personnel away from the Lift.
 20. Do not make any modifications to the Lift; this voids the warranty and increases the chances of injury or property damage.
 21. Do not use the Lift while tired or under the influence of drugs, alcohol, or medication.
 22. Consider the work environment. Keep the work area clean. Cluttered work areas invite injuries. Keep areas well lit.
 23. **Always** make sure the Lift is secured on Safety Locks before attempting to work on or near a Vehicle.
 24. Make a thorough inspection of the product at least once a year. Replace any damaged or severely worn parts, decals, or warning labels. Replace worn or damaged parts with BendPak or BendPak approved parts and assemblies only.
 25. BendPak recommends referring to the ANSI/ALI ALIS Standard *Safety Requirements for Installation and Service* for more information about safely installing, using, and servicing your Lift.
 26. The MaxJax M7K Lift is a Mid-Rise Service Lift. **Use it only for its intended purpose.**
 27. You **must** wear OSHA-approved (publication 3151) personal protective equipment at all times when installing, using, maintaining, or repairing the Lift. Leather gloves, steel-toed work boots, eye protection, back belts, and hearing protection are **mandatory**.
 28. Keep loads balanced on the Lift Arms at all times. Clear the area immediately if a Vehicle is in danger of falling off the Lift.
 29. Do not make any modifications to the Lift. Modifications void the warranty and increases the chances of injury or property damage. Do not modify any safety-related features in any way.
 30. Make sure all operators read and understand this Installation and Operation Manual. Keep the manual near the Lift at all times.
 31. While handling a Hydraulic Cylinder or a Hydraulic Hose, **always** wear gloves. In rare cases, a needle-like stream of hydraulic fluid (even at low pressure) can penetrate fingers, hands, or arms; such a puncture can feel like a bite, electric shock, or a needle prick. While it may seem like a minor issue, any amount of Hydraulic Fluid injected into the human body is a serious issue. Anyone suffering such a puncture wound should be **immediately** taken to a hospital emergency room to determine the extent of the injury. Explain the circumstances of the injury to the attending physician, including what kind of Hydraulic Fluid was involved. Do not assume a puncture wound that could have been caused by Hydraulic Fluid is a minor issue; it could be life threatening.
 32. MaxJax is portable, so you may move it to different mounting locations around your workspace; however, when the Lift is in use, it **must** be anchored in place.
 33. Make sure the Lift Controls are dry, clean, and free from grease and oil.
 34. Make a visual inspection of the product before using it. Check for damage, worn or missing parts. Do not use the product if you find any issues. Instead, take it out of service, then contact your dealer, email support@maxjax.com, visit maxjax.com/support, or call **(844) 629-5291**.
 35. Make a thorough inspection at least once a year. Replace any damaged or severely worn parts, decals, or warning labels.

Symbols

Following are the symbols used in this manual:

 **DANGER** Calls attention to an immediate hazard that **will** result in injury or death.

 **WARNING** Calls attention to a hazard or unsafe practice that **could** result in injury or death.

 **CAUTION** Calls attention to a hazard or unsafe practice that could result in minor personal injury, product, or property damage.

NOTICE Calls attention to a situation that, if not avoided, could result in product or property damage.



Tip

Calls attention to information that can help you use your product better.

Liability Information

BendPak Inc. assumes **no** liability for damages resulting from:

- Use of the product for purposes other than those described in this manual.
- Modifications to the equipment without prior, written permission from BendPak Inc.
- Injury or death caused by modifying, disabling, overriding, or removing safety features.
- Damage to the equipment from external influences.
- Incorrect operation of the equipment.

Specifications

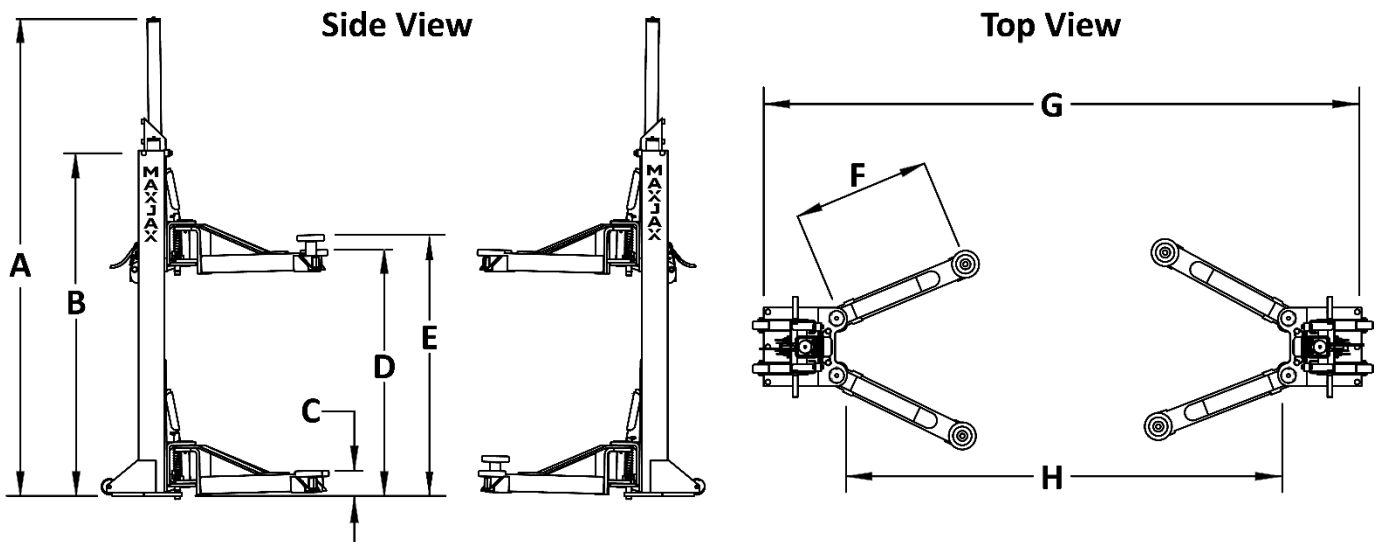

Model	M7K
Lifting capacity	7,000 lbs. / 3,175 kg
Maximum capacity front axle	3,500 lbs. / 1,587 kg
Maximum capacity rear axle	3,500 lbs. / 1,587 kg
Max Load per Arm	1,750 lbs. / 794 kg
A Overall Height (Hydraulic Cylinders at full height)	89.5" / 2,273 mm
B Column Height	64" / 1,629 mm
C Minimum Pad Height	5.5" / 138 mm
D Maximum Lift Height (Pad Only)	47.5" / 1,204 mm
E Maximum Lifting Height (with 2.75" Adapter)	50" / 1,270 mm
F Arm Reach (Min.-Max.)	26" / 658 mm – 40" / 1,016 mm
G Typical Width (Outside Edge of Base Plates, Min. – Max.)	105" / 2,667 mm – 135" / 3,429 mm
H Drive-thru Clearance	74" / 1,883 – 104" / 2,642 mm
Safety Locks	8
Post Weight	300 lbs. / 136 kg
Raising/Lowering Time*	45 seconds
Motor**	110/220 VAC, 50/60 Hz, 1 Ph

* Lowering is much slower with no Vehicle on the Lift.

**Must specify at time of purchase.

Specifications subject to change without notice.

Operation

This section describes how to operate your MaxJax.

⚠ DANGER Automotive Lifts are dangerous tools when used by inexperienced or impaired operators. When you even hear the words “Automotive Lift,” your brain should automatically remember that lifting a **Vehicle is a serious endeavor with life-threatening risks**. Focus on what you are doing.

Operating the MaxJax Safely

⚠ WARNING Your safety is dependent on reading, understanding, and implementing these Safety Rules. **Do not skip over them—read them carefully and follow them; your life could literally depend on it!**

Do the following **before** you raise a Vehicle on your MaxJax, do the following each time:

- **Check the Lift.** Walk all the way around the Lift, checking for any missing, heavily worn, or damaged parts. Do not operate the Lift if you find any issues; instead, take it out of service, then contact your dealer, email support@maxjax.com, or call **(844) 629-5291**.
- **Check the area.** Keep the area around and under the Lift clean and free of obstructions; anything that could impact the raising or lowering of the Vehicle. Do not forget to check **above** the Lift. Remove obstructions. The MaxJax is intended for indoor use and has an operating ambient temperature range of +41° to +104°F (+5° to +40°C). **Outdoor installations are prohibited.**
- **Check the operators.** Make sure everyone who is going to operate the Lift has been trained in its use, has read the labels on the unit, and has read the manual. Only the operator at the Controls should be within 30 feet of the Lift while it is moving. Do not allow children to operate the Lift. Do not allow anyone under the influence of drugs, alcohol, or medication to operate the Lift. Do not allow any unauthorized personnel to operate the Lift.
- **Check for safety.** Make sure everyone who is going to be walking near the Lift is aware of its presence and takes appropriate safety measures. Only put Vehicles on the Lift. When raising a Vehicle, do not leave it until it is **engaged** on a Safety Lock. When lowering the Lift, do not leave it until it is on the ground.
- **Check the Vehicle.** Never exceed the Lift’s weight rating. Do not allow people inside a Vehicle you are going to raise. Make sure the Vehicle is not overbalanced on either end or either side. You must use the factory-recommended Lifting Points for the Vehicle. Never raise just one side, one corner, or one end of a Vehicle. Refer to the *Lifting it Right: A Safety Manual from ALI and Vehicle Lifting Points for Frame Engaging Lifts* guide shipped with your Lift.

⚠ WARNING A complete pre-operation inspection is required before using this equipment.







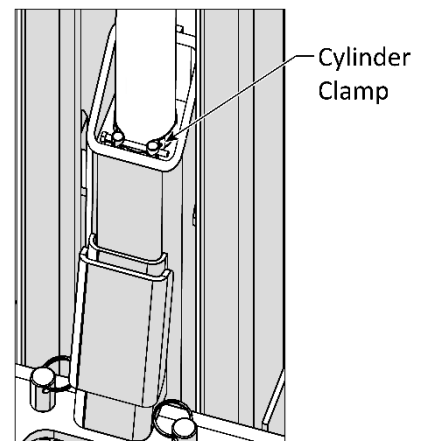



⚠ WARNING The Hydraulic Hoses and connections must be inspected before any attempt to raise a Vehicle is made.

⚠ WARNING Always verify the Cylinder Clamp is secured in place on **both** Lift Cylinders above the Lift Head.

⚠ WARNING **Always** promptly clean any Fluid spills. If a leak is the source of the spill, lockout the Lift to prevent use until the Hydraulic System is repaired.



Hydraulic System Warnings

-  **WARNING** Failure to observe these precautions can result in serious personal injury, including, in rare cases, death.
-  **WARNING** Do **not** run your Power Unit without Hydraulic Fluid; it will be damaged.
-  **WARNING** All Hydraulic Hose fittings must be inspected before any attempt is made to raise a Vehicle.
-  **WARNING** Do not attempt to connect or disconnect Hydraulic Hoses while equipment is loaded or while the Hydraulic System is under pressure.
-  **WARNING** Keep the Hydraulic System clean; keep the Quick-Connect Fittings free of debris.
-  **WARNING** Keep bare hands away from Hydraulic Fluid; always wear gloves when handling Hydraulic Cylinders or Hydraulic Hoses.
-  **WARNING** Before applying power to the Hydraulic system, systematically verify all hydraulic connections are tight, including fittings, hoses, and auxiliary port plugs. Inspect for pinched or damaged Hydraulic Hoses and replace before operation.
-  **WARNING** When handling Hydraulic Fluid, observe the safety instructions from the manufacturer.
-  **WARNING** This Hydraulic Power Unit cannot be run continuously. The motor is not rated for continuous duty.
-  **WARNING** The MaxJax is a Hydraulically Balanced Lift. The Hydraulic Hoses supplying the Lift Cylinders must be the same length within 5%. If a hose is replaced verify the length is within 5% of the original MaxJax Hydraulic Hose.
-  **WARNING** This Power Unit contains a Hydraulic Pump capable of developing extremely high pressure. A Pressure Relief Valve is used to set the pressure at the desired level. Tampering with, adjusting, modifying, or removing the Relief Valve is extremely dangerous. Only trained Hydraulics technicians, using calibrated Hydraulic Pressure Gauges to assure the proper pressure setting is achieved, should make adjustments to the Relief Valve.

Additional Operating Information

Keep the following in mind when operating your MaxJax:

- Use it only on a hard, flat surface. MaxJax is portable; if you move it to a new location, make sure the location has a hard, flat surface.
- Always verify that you have the proper overhead clearance.
- **Visually inspect the Lift before each use.** Do not use it if you find any damage or severe wear to the Lift components.
- Both Posts **must** be anchored in place when the Lift is in operation.

-
- Make sure the Anchor Bolts are securely tightened before each use; if any Anchor Bolts are loose, do not use the Lift until all Anchor Bolts are adjusted.
 - Do not block, open, or override self-closing Lift Controls; they are designed to return to the “Off” or Neutral position when released.
 - Always remain clear of the Lift when raising or lowering Vehicles.
 - Do not attempt to lift a Vehicle in any way with less than all four Lift Arms.
 - Do not remove or disable the Lift Arm Restraints.
 - Do not rock the Vehicle or remove heavy components while on the Lift; removal of Vehicle components may alter the weight distribution.
 - Do **not** begin working on the Vehicle until you have confirmed that both Lift Heads are securely engaged on a Safety Lock position.
 - Never move under a raised Vehicle without first confirming that both Safety Locks are secured on a locking position of the same height.
 - Always remove tools, trays, and all other equipment before lowering the Lift.
 - Never drive over the Lift Arms; make sure to rotate the Lift Arms to provide an unobstructed exit before moving the Vehicle from the Lift area.

About Lifting Points, Lift Pad Adapters and Lift Pad Extensions

An important note to keep in mind when using the MaxJax is that the raised Vehicle must be balanced on the four Lift Arms. If the Vehicle is not balanced, it is more likely to become unstable and slide off the Lift, possibly damaging the Lift, the Vehicle, and anything under the Lift, including injuring people.

 **WARNING** You **must** use all four Lift Arms when raising a Vehicle. Never use just one, two, or three Lift Arms to raise a Vehicle. The Vehicle will be unstable and could slip off the Lift, possibly damaging the Lift, damaging the Vehicle, and injuring anyone under it.

To balance a Vehicle on the MaxJax Lift, you need to have the Lift Pad Adapters contact the Vehicle on the manufacturer’s recommended Lifting Points. By definition, when you raise a Vehicle by its Lifting Points, the Vehicle is balanced.

NOTICE The manufacturer’s recommended Lifting Points do not take into consideration any major changes that might have been made to the Vehicle. If the motor is removed, for instance, or there is a 5,000 pound / 2,268 kg weight in the trunk, the Vehicle’s Lifting Points will not be the best balancing points.

Some Vehicles have indicators on the underside that identify the Lifting Points; many do not.

The best approach is to find the Vehicle’s recommended lifting points in the *Vehicle Lifting Points for Frame Engaging Lifts* guide, which is provided with your Lift, or contact the manufacturer of the Vehicle. This guide also includes safe lifting suggestions, which everyone who uses the Lift should read.

Lifting it Right: A Safety Manual from the Automotive Lift Institute, also provided with your Lift, includes a wide variety of information about Lifts and how to use them safely.

The Lift Pad Adapters and Lift Pad Extensions (also called height adapters) supplied with every MaxJax Lift include:

- **Four Round Lift Pad Adapters** (5215507).
- **Four Medium Lift Pad Extensions** - Ø35 x 113 mm (5746390).

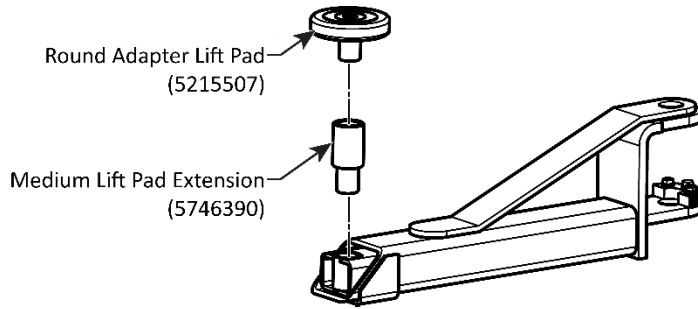

MaxJax Accessories include a variety of Stackable Lift Pad adapters and Frame Cradle Pads.

Raising a Vehicle

This section describes how to raise a vehicle on the MaxJax Lift.

⚠ WARNING Never raise a Vehicle whose weight exceeds the rated capacity of the Lift. Do not leave the controls until the Lift is engaged on a Safety Lock position or fully lowered. Only trained personnel should raise and lower the Lift.

To Raise a Vehicle:

1. Check the items listed in **Safety Considerations**.
2. Verify the Lift is fully lowered to the ground and the Lift Arms are rotated out of the Vehicle's path in the full drive-through position.
3. Carefully drive the Vehicle in between the Lift Posts and then stop.

⚠ CAUTION When driving a Vehicle into position, keep to the middle of the area between the Posts. If you hit a Lift Arm or any other portion of the Lift, you could damage the Vehicle and/or the Lift.

4. Put the Vehicle in park, put on the parking brake, and turn off the Vehicle.
If the Vehicle is a manual transmission, put it into first gear before turning off the motor.
5. Get out of the Vehicle; open the doors carefully to avoid damaging them on the Lift's Post.
6. Position the Lift Arms until the Lift Pads are under the Vehicle and **directly under** the manufacturer's recommended Lifting Points for the Vehicle you are raising.

⚠ WARNING Do not guess the best location for the Adapters. **You must use the manufacturer's recommended Lifting Points.** If you do not, the Vehicle could become unstable and fall, which could damage the Vehicle, damage the Lift, or injure or even kill anyone under the Vehicle.

If you are unsure where the Lifting Points are, consult *Vehicle Lifting Points for Frame Engaging Lifts*, which was provided with the Lift, or the manufacturer of the Vehicle. If you no longer have *Vehicle Lifting Points for Frame Engaging Lifts*, contact MaxJax support maxjax.com/support, by email at support@maxjax.com, or by phone at **(844) 629-5291**, to secure a replacement copy.

Some vehicles may have the manufacturers' recommended Service Garage Lift Point locations identified by a triangle mark on the underside of the vehicle, reference SAE J2184-(Current Edition). On some vehicles, specific Lifting Points are indicated by a label located on the driver's side door jamb.

⚠ WARNING Many specialty or modified Vehicles or Vehicles with unusually short or long wheelbases cannot be on raised on a Two-Post Frame Engaging Lift. Contact the Vehicle's manufacturer for Raising or Jacking guidance.

⚠ DANGER *Never place Contact Pads on non-approved, non-load holding Sill Covers or Side Skirts!*

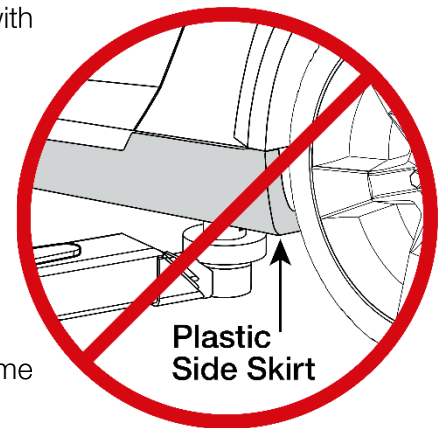

The figure below illustrates typical lifting points based on Vehicle Frame type.

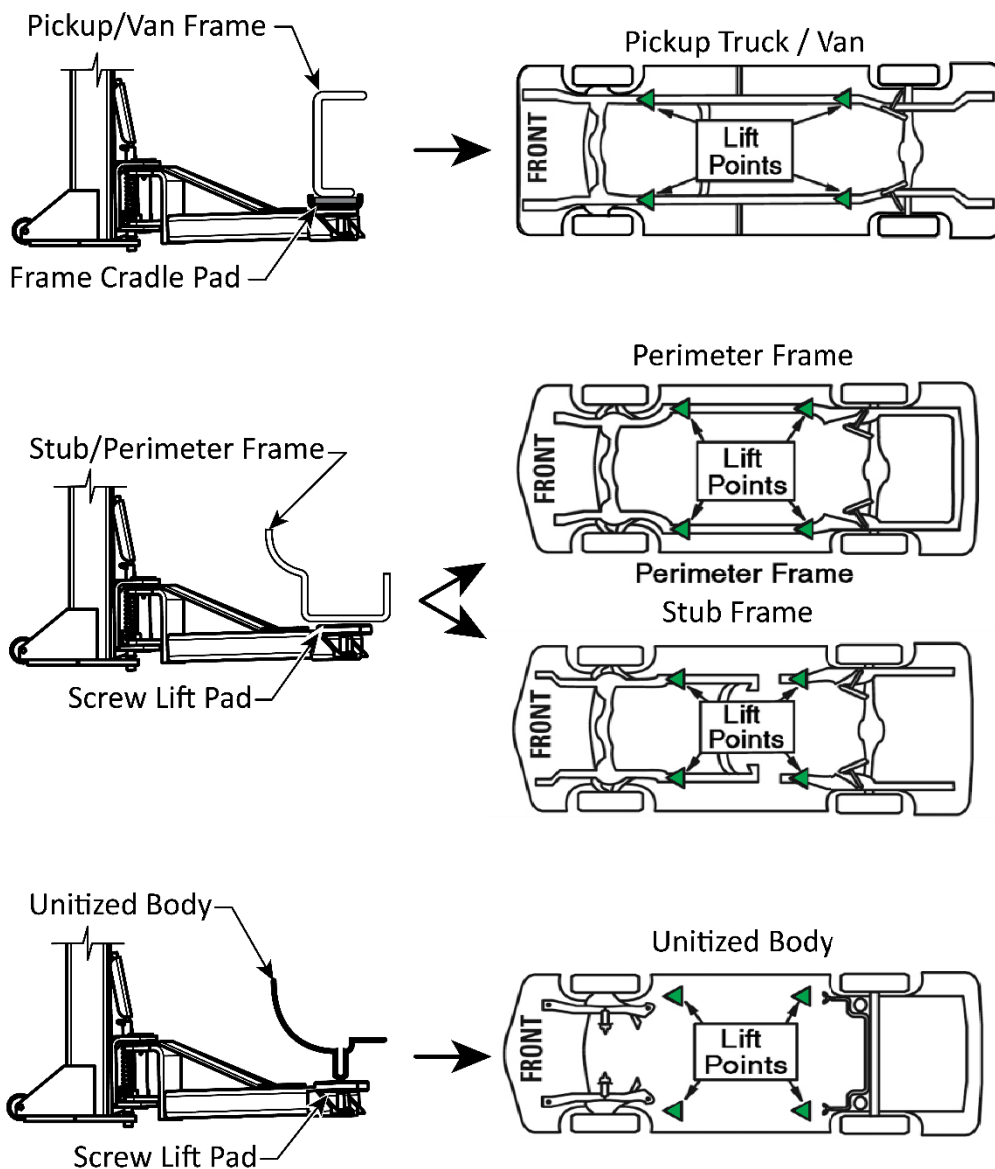

-
- ⚠ WARNING** Before attempting to lift a Vehicle verify:
- The Vehicle Frame is strong enough to support its weight and has not been weakened or compromised by modification, damage or corrosion.
 - The Vehicle individual axle weight does not exceed one-half the Lift capacity.
 - The Lift Adapters are in secure contact with the Frame at the Vehicle manufacturers' recommended Lift Points.
 - The Vehicle is stable on the Lift and the center of gravity is not shifted making the Vehicle off balance.
- ⚠ WARNING** Always use Safety Stands when removing or installing heavy components that may affect the Vehicle's center of gravity.
- ⚠ WARNING** Use the correct Adapters. Do not attempt to lift trucks or other frame type vehicles with standard Rubber Contact Pads.
- ⚠ WARNING** Never use the Lift with missing or damaged rubber Contact Pads. Always replace Rubber Contact Pads when worn or damaged.
7. Verify the **both** Safety Lock Release Cam handles are **down** in the **engage** position. Refer to the figure below.

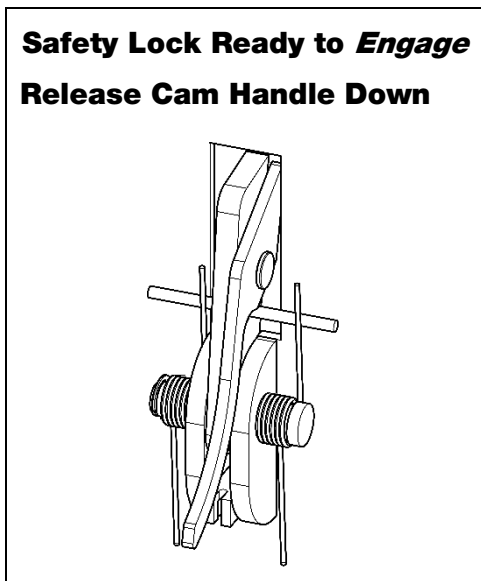

8. Press and hold the **Up** Button on the Power Unit to raise the Lift until **just before** the Adapters make contact with the Lifting Points, then release the **Up** Button.
9. Check the Arm Restraint Gears **on all four Lift Arms** to make sure they are engaged and that the Lift Pads will make solid contact with the Lifting Points when raised further.
- a. To **disengage** the Arm Restraint Gear and unlock the Lift Arm, use the Ring to lift up on the Shaft. Refer to the figure on the next page.
 - b. To **engage** the Arm Restraint Gear and lock the Lift Arm, push down on the Shaft while rocking the Lift Arm slightly. Refer to the figure on the next page.

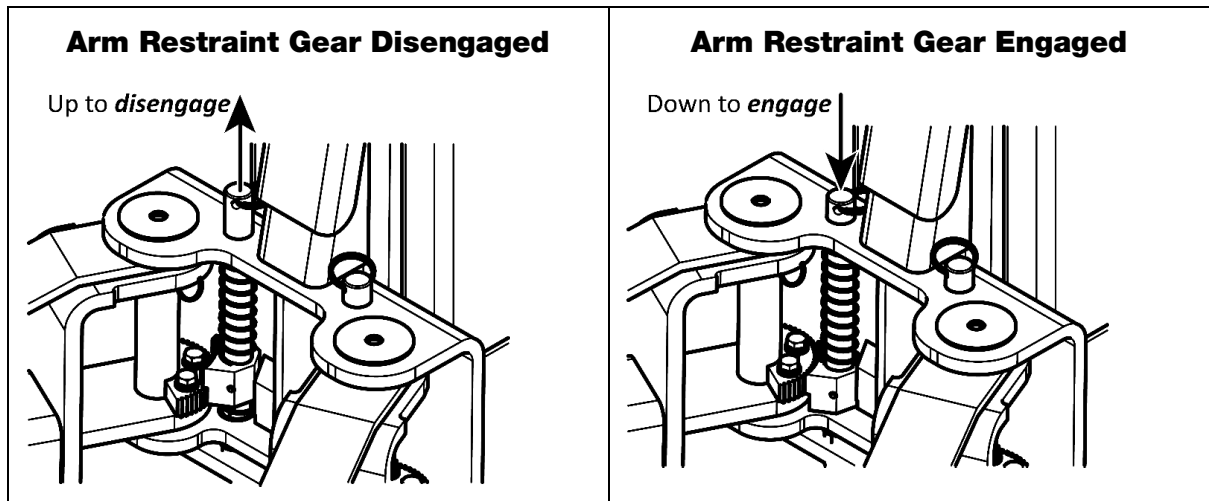

10. Press the **Up** Button until the Tires of the Vehicle are a few inches off the ground.
If the Lift becomes unstable or the Vehicle starts moving, release the **Up** Button immediately.
11. Verify all four of the Lift Pads are making solid contact with the Lifting Points.
If any of the Lift Pads are **not** making solid contact with the Lifting Points, lower the Lift and adjust the Lift Arms and Pads until they make better contact.
12. When the Vehicle is just a few inches off the ground, rock the Vehicle to make sure it is stable and balanced.
 - If the Vehicle is **not** stable and balanced, lower the Lift back to the ground and start over.
 - If the Vehicle **is** stable and balanced, you can raise it to the desired height.

⚠ DANGER Do **not** raise the Lift further until you are certain the Vehicle on the Lift is both stable and balanced. If the Vehicle is **not** stable and balanced, it could fall, which could damage the Vehicle, damage the Lift, or injure or kill anyone under the Vehicle.

⚠ WARNING Always keep a line of sight on the Lift at all times. Ensure personnel and objects are clear of the Lift at all times.

⚠ WARNING Remain Clear of the elevated Lift until visual confirmation is made that all Safety Locks are fully engaged and the Lift is lowered onto the Safety Locks.

13. Raise the Lift until the Vehicle reaches the desired height, go up a bit further, then release the **Up** Button.
14. Press and hold the Lowering Handle briefly to move the Lift back down, which engages it on the closest Safety Lock.
15. When the Lift stops moving down, it is engaged on its Safety Locks; release the Lowering Handle.

Do not leave the Lift controls unless the Lift is engaged on its Safety Locks or fully lowered.

If you miss the desired Safety Lock, press and hold the **Up** Button again and move just past the desired Safety Lock. You'll hear a click indicating the Safety Lock has passed a Safety Block. Release the **Up** Button, then hold the Lowering Handle again to lower the Lift onto the desired Safety Lock.

⚠ DANGER Do **not** move under the Vehicle until you have confirmed that the Lift is engaged on Safety Locks.

⚠ DANGER Always ensure both Safety Locks are engaged. If the Lift Heads are engaged on Safety Locks at two different heights or only one Safety Lock is engaged, the Vehicle could become unbalanced and fall causing damage, injury or death.

16. Recheck the Lift Arms and Pads to verify they are still making solid contact with the Vehicle Lifting points.
17. Verify the Lift is engaged on the same Safety Lock on both posts (all four arms are at the same height).
18. Begin work on the Vehicle.

Lowering a Vehicle

NOTICE If the MaxJax *CE Safety Release Kit* is installed on this Lift, refer to **Lowering a Vehicle using the CE Safety Release Kit** Section, below.

1. Check under and around the Vehicle to verify the area is clear of all personnel, tools and obstructions.
2. Press and hold the **Up** Button on the Power Unit for a few seconds. This moves the Lift Heads off of the Safety Locks.
3. On each Post, move the Safety Lock Release Cam handle **Up** to the **disengage** position. Refer to the figure below.

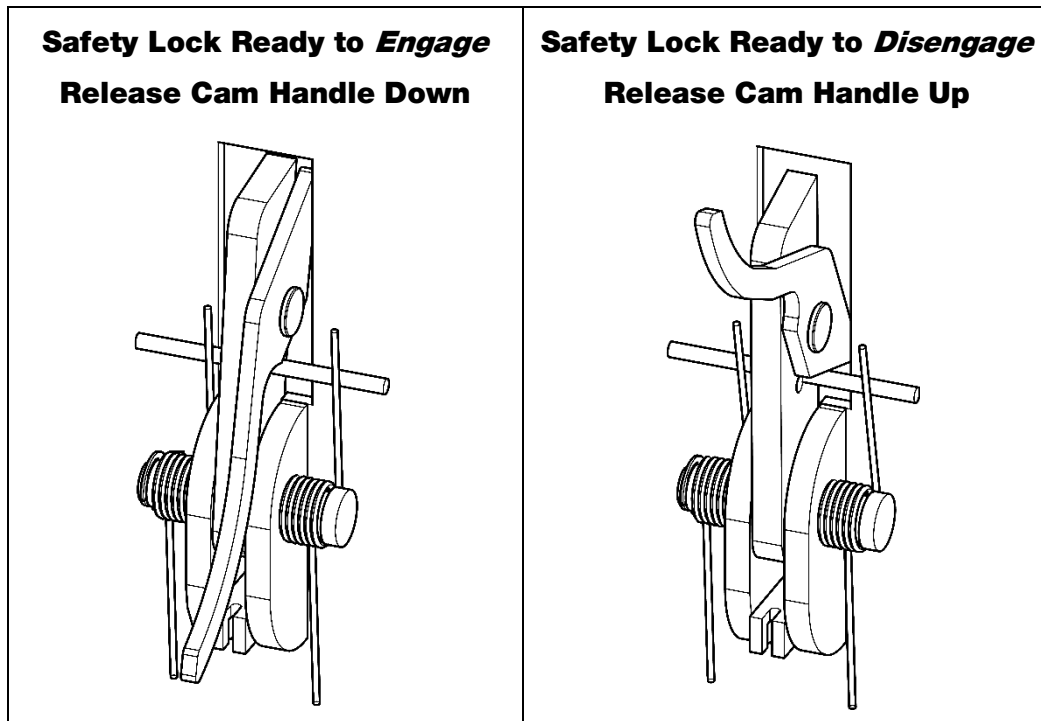

4. **Press** and **hold** the Lowering Handle on the Power Unit.

⚠ WARNING Stay clear of the Lift as it lowers; obey the pinch points warning decals.

5. When the Lift is fully lowered to the ground, release the Lowering Handle on the Power Unit.
6. Return both Safety Lock Release Cam Handles to the **down** or ready to engage position.
7. When the Lift Arms have lowered enough to clear the bottom of the Vehicle, rotate the Lift Arms out from under the Vehicle and toward the MaxJax Posts into the full drive-through positions.

This clears a path for the Vehicle to move out of the Lift area.

8. Carefully drive the Vehicle out of the Lift.

Lowering a Vehicle using the CE Safety Release Kit

NOTICE The following procedure is intended for MaxJax Lifts equipped with the *CE Safety Release Kit* only.

1. Check under and around the Vehicle to verify the area is clear of all personnel and obstructions.
2. Move the Lift Heads off the Safety Locks by pressing and holding the **Up** Button on the Power Unit for a few seconds.
3. Squeeze and hold the CE Safety Release Handle. If the Safety Release Handle will not move, the Lift Heads are not yet clear of the Safety Locks. Press and hold the **Up** button on the Power Unit for a few more seconds, then attempt to squeeze and hold the Safety Lock Release again.

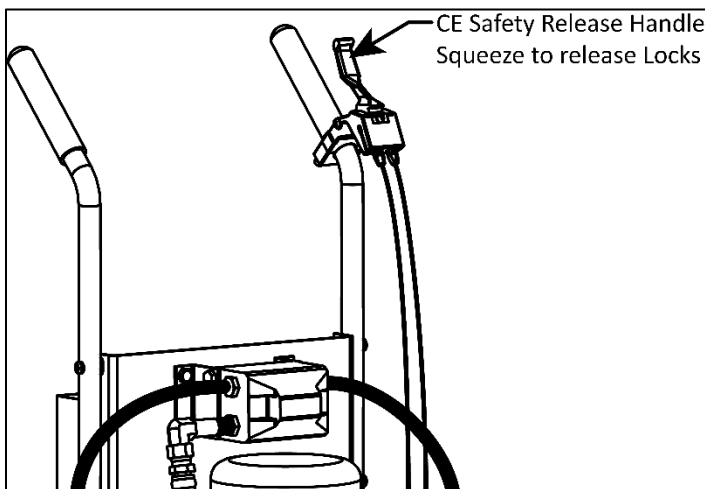

Press and *hold* the Lowering Handle on the Power Unit while squeezing and holding the Safety Lock Release.

⚠ WARNING Stay clear of the Lift as it lowers; obey the pinch points warning decals.

4. When the Lift Arms have lowered to the ground, release the CE Safety Release Handle and the Lowering Handle on the Power Unit.
5. The Lift Arms should have lowered enough to clear the bottom of the Vehicle, rotate the Lift Arms out from under the Vehicle and towards the MaxJax Frame.

This clears a path for the Vehicle to move out of the Lift area.

6. Carefully drive the Vehicle out of the Lift.

Moving the Lift

The MaxJax is portable, which means you can move it around your work space, if you have installed additional anchors.

To move the Lift:

1. Make sure the Lift is fully lowered and the Lift Arms have been removed.

 **WARNING** Do not connect or disconnect the Hoses with the Lift in an elevated position.

2. Press and hold the Lowering Handle for a few seconds to relieve any hydraulic pressure in the Hydraulic Hoses.
3. Unplug the Power Cord and wrap it around the Portable Stand.

 **DANGER** Do *not* perform any maintenance or reinstallation without first making sure that the Lift is **completely disconnected from the power source** and cannot be re-energized until all maintenance tasks are complete.

4. Put a clean rag under the hydraulic connections near the bottom of the Hydraulic Cylinder, then disconnect the Hydraulic Hose.

Make sure to clean any Hydraulic Fluid from the Hydraulic Hoses.

5. Loosen then remove the five Anchor Bolts from the Base Plate; Remove any shims and keep both the Bolts and shims handy for future use.

 **CAUTION** Be careful not to disturb the Post until you are ready to move it to your storage area.



Tip

We recommend that you mark or otherwise note the Shim locations used at each Anchor to help at the time of re-installation.

6. Insert an Anchor Plug (5530412) in each Anchor Sleeve in the ground, to prevent the Anchor Sleeves from filling with debris while the Posts are in storage.
7. Using a downward force, push and tilt the Post onto its Wheels, and then carefully move the Post to the desired location.
8. Repeat Steps 4 through 7 for the other Post.

Re-installation

When you are ready, you can easily re-install your MaxJax using the Anchor Sleeves already in place.

To re-install your Lift:

1. Verify the installation area and path is clear of debris, tools, and equipment.
2. Remove the Anchor Plugs (5530412) from each anchor.
3. Clean the Anchor holes with compressed air or with a nylon brush.

 **WARNING** You must wear OSHA-approved (publication 3151) personal protective equipment at all times when installing, using, maintaining, or repairing the Lift: safety glasses, leather gloves, steel-toed boots, back belts, and hearing protection are required.

4. Make a visual inspection of all the Drop-in Anchors for damage or extreme wear.

 **WARNING** You must inspect all Drop-in Anchors for proper setting and or damage ***each time the Lift is re-installed***. Do ***not*** use the Lift if the Drop-in Anchors are damaged, extremely worn, or if the Concrete is cracked or defective.

5. Align the Posts with the Anchor locations.
6. Verify the Lift Arms are level, the Lift Posts are Perpendicular to the Floor and install any needed Shims under the Base Plates.
7. Tighten all the Anchor Bolts in place.

Important: Do ***not*** use an impact wrench to tighten the Anchor Bolts.

 **DANGER** The Lift must be re-leveled, shimmed, and bled each time the Lift is re-installed. Failure to do so may result in damage to the Lift or serious injury.

Maintenance

 **DANGER** Before performing maintenance on your Lift, verify it is disconnected from power. The Lift uses electrical energy; if your organization has Lockout/Tagout policies, make sure to implement them before performing any maintenance. If you come into contact with high voltage/current, you could be injured or killed.

A complete pre-operation inspection is required before using this equipment.

Read your manual and understand how this equipment works before using, maintaining or repairing. Routine maintenance and adjustments are the responsibility of the owner/user and are not covered under warranty.

Routine maintenance and adjustments should be carried out on a regular basis. *Unless stated otherwise, all maintenance may be performed by the owner/employer and does not require trained lift service personnel.* Replace worn, damaged or broken parts with original BendPak or BendPak approved parts or with parts that meet or exceed the original specifications.

Routine maintenance and adjustments are the **responsibility of the owner/user** and are **not** covered under warranty.

To maintain your Lift:

- **Daily:** Keep the Lift clean. Wipe up any oil spills, clean any dirt.
- **Daily:** Make a visual inspection of all moving parts and check for damage or excessive wear. If you find any damaged or worn parts, take the Lift out of service until they are replaced.
- **Daily:** Make sure the Safety Locks are in good operating condition. If you find that the Safety Locks are damaged or excessively worn, take the Lift out of service until they are replaced. **Do not use your Lift if the Safety Locks are damaged or excessively worn.**
- **Daily:** If the CE Safety Release Kit is installed, verify the Safety Locks engage and disengage freely. If you find that the Safety Release mechanism is damaged or excessively worn, take the Lift out of service until is repaired or replaced.
- **Daily:** Verify the Cylinder Clamp is secured and in place at the top of the Lift Head.
- **Weekly:** Check all controls to make sure they are functioning normally.
- **Weekly:** Check all labels on the unit. Replace them if they are illegible or missing.
- **Monthly:** Lubricate the inside of the Posts where the Lift Head's Slide Blocks move. We recommend using white lithium grease or similar.
- **Monthly:** Make sure all pivot arm pins are properly secured.
- **Monthly:** Check the Power Unit's Hydraulic Fluid levels. Refill if low.

 **WARNING** If one of the long Hydraulic hoses requires replacement, replace it with a hose of the same length $\pm 5\%$. The MaxJax is a Hydraulically Equalized Lift. Unequal Hose lengths may cause unequal lifting, resulting in an imbalance and subsequent loss of load. Order a replacement hose, contact MaxJax support at maxjax.com/support, via email support@maxjax.com, or call **(844) 629-5291**.

 **WARNING** Do not operate your Lift if you find maintenance issues; instead, take it out of service, then contact your dealer, email support@maxjax.com, visit maxjax.com/support, or call **(844) 629-5291**.

Troubleshooting

Note: If your Lift is not functioning correctly, you must take it out of service until it is repaired.

Important: Unless stated otherwise, all maintenance may be performed by the owner/employer and does not require trained lift service personnel.

⚠ WARNING The Lift uses electrical energy; if your organization has Lockout/Tagout policies, make sure to implement them before performing any Troubleshooting.

Issue	Action to Take
Lift becomes inoperative with vehicle raised.	Verify the Lift Head is clear of the Safety Locks and the Safety Lock has been disengaged before attempting to lower the Lift. If the Lift continues to be inoperative, contact MaxJax Support by email at support@maxjax.com or by phone at (844) 629-5291 .
Arms move erratically or squeaks when in use.	Move the Arms up and down a few times, with a break between each; there could be residual air in the Hydraulic System.
Lift does not go up or down.	<p>Make sure there is sufficient Hydraulic Fluid in the Reservoir.</p> <p>Make sure the Power Unit is connected to an appropriate power source.</p> <p>Make sure there is no air in the Hydraulic System.</p> <p>Make sure none of the Hydraulic Hoses are pinched or leaking.</p> <p>If the Hydraulic Fluid is dirty, replace it with clean Fluid.</p>
Lift does not stay up.	<p>Make sure to leave the Lift engaged on its Safety Locks.</p> <p>Check for Hydraulic Fluid leaks.</p>
Vehicle on the Lift is not level.	<p>Verify the Lift is engaged on Safety Locks at the same height.</p> <p>Make sure the Safety Locks in both Posts are engaged.</p> <p>If the Lift is not on a Safety Lock, carefully lower the Vehicle back down to the ground and raise it again.</p>
Motor is not running.	<p>Check connection to power source; make sure it is plugged in and the appropriate voltage.</p> <p>Check wiring diagram.</p>
Lift makes odd noises when in use.	Lubricate the Slide Blocks and hinge points using white lithium grease. Cycle the Lift up and down a few times to bleed air out of the system.

If you continue to have problems with your Lift, take the Lift out of service, then contact your dealer, visit maxjax.com/support, via email support@maxjax.com, or call **(844) 629-5291**.

Labels



PN 5906033

⚠ WARNING

ENGAGE SAFETY LOCKS

ALWAYS make sure the lift is lowered onto the safety locks and fully engaged before working on or near the vehicle. Failure to do so may result in **SERIOUS INJURY OR DEATH.**

Safety in **LOCKED** Position
Sécurité en position
VERROUILLÉE

Safety **NOT** Locked
Sécurité **NON** verrouillée

Safety lock **DISENGAGED** (To lower)
Verrou de sécurité **DÉSENGAGÉ**
(Baisser)

S Safety Lock
Verrou de sécurité

R Release Cam
Libérer la came

S Safety Lock Blocks
Blocs de sécurité

⚠ ATTENTION

ENGAGER LES VERROUS DE SÉCURITÉ

TOUJOURS s'assurer que le pont élévateur est abaissé sur les verrous de sécurité et complètement engagé avant de travailler sur ou à proximité du véhicule. Ne pas le faire peut entraîner des **BLESSURES GRAVES OU LA MORT.**

PN 5906033

PN 5906035

⚠ IMPORTANT OPERATION / MAINTENANCE - PLEASE READ
FONCTIONNEMENT / MAINTENANCE - VÉRIFIEZ LIRE

⚠ DANGER ⚠

CYLINDER BLEEDING INSTRUCTIONS

INSTRUCTIONS DE PURGE DES CYLINDRES

LIFT OPERATION **OPÉRATION DE LEVAGE**

USE PROPER ADAPTERS **UTILISEZ LES ADAPTEURS APPROPRIÉS**

FRAME CRADLE ADAPTERS **ADAPTEURS DE BENCHALU DE CHASSIS**

SUV & VAN ADAPTERS **ADAPTEURS SUV ET VAN**

⚠ WARNING **⚠ AVERTISSEMENT**

TO PLACE ORDER / POUR PASSER COMMANDE

visit / visite www.MaxJax.com or call / appelez 1-866-963-5655

⚠ ATTENTION ⚠

MAXIMUM LIFTING CAPACITY
CAPACITÉ DE LEVAGE MAXIMUM

7000 Lbs.

3175 Kg.

PN 5906044

PN 5906045

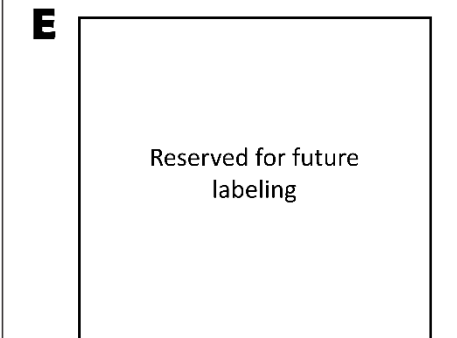

MAXJAX
MaxJax is a wholly owned subsidiary of Blaupunkt, Inc.

1645 Lemonwood Drive
Santa Paula, CA USA
www.MaxJax.com

MODEL NUMBER	
DESCRIPTION	
LIFT CAPACITY	DATE CODE
VOLTAGE	SERIAL NUMBER
UPC	

⚠ DANGER!
Disconnect Power Before Servicing

UK CE EAC

MADE IN CHINA WARRANTY VOID IF DATA PLATE IS REMOVED PN 5906036

NOTICE

If attachments, accessories, or configuration modifying components used on this lift are located in the load path and affect operation of the lift, affect the lift electrical listing, or affect intended vehicle accommodation; and if they are not certified for use on this lift, then the certification of this lift shall become null and void. Contact the participant for information pertaining to certified attachments, accessories, or configuration modifying components.

www.autolift.org ©2011 by ALI, Inc. ALI / WLSIA01

PN 5906377

H

NOTICE	NOTICE
Read operating and safety manuals before using lift.	Proper maintenance and inspection is necessary for safe operation.
NOTICE	NOTICE
Do not operate a damaged lift.	The messages and pictographs shown are generic in nature and are meant to generally represent hazards common to all automotive lifts regardless of specific style. Funding for the development and validation of these labels was provided by the Automotive Lift Institute, P.O. Box 33116 Jacksonville, FL 32003. They are protected by copyright. Set of labels may be obtained from ALI or its member companies.

PN 5905109

I

CALIFORNIA PROPOSITION 65

⚠ WARNING ⚠

WARNING! This product can expose you to chemicals including styrene and vinyl chloride which are on the list of over 900 chemicals identified by the State of California to cause cancer, birth defects or reproductive harm. ALWAYS use this product in accordance with the manufacturer's instructions. For more information, go to www.p65warnings.ca.gov.

PN 5905775

CAUTION	CAUTION
Lift to be used by trained operator only.	Authorized personnel only in lift area.
CAUTION	CAUTION
Use vehicle manufacturer's lift points.	Always use safety stands when removing or installing heavy components.
CAUTION	CAUTION
Use height extenders when necessary to ensure good contact.	Auxiliary adapters may reduce load capacity.

The messages and pictographs shown are generic in nature and are meant to generally represent hazards common to all automotive lifts regardless of specific style. Funding for the development and validation of these labels was provided by the Automotive Lift Institute, P.O. Box 33116 Jacksonville, FL 32003. They are protected by copyright. Set of labels may be obtained from ALI or its member companies.

WARNING	WARNING
Clear area if vehicle is in danger of falling.	Position vehicle with center of gravity midway between adapters.
WARNING	WARNING
Remain clear of lift when raising or lowering vehicle.	Avoid excessive rocking of vehicle while on lift.
WARNING	WARNING
Do not override self-closing lift controls.	Keep feet clear of lift while lowering.

The messages and pictographs shown are generic in nature and are meant to generally represent hazards common to all automotive lifts regardless of specific style. Funding for the development and validation of these labels was provided by the Automotive Lift Institute, P.O. Box 33116 Jacksonville, FL 32003. They are protected by copyright. Set of labels may be obtained from ALI or its member companies.

J



PN 5906044

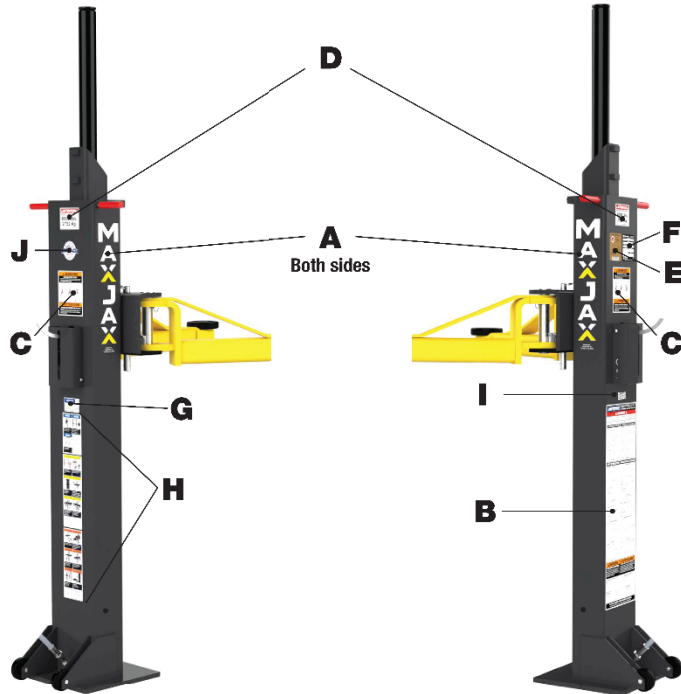

Part Drawings

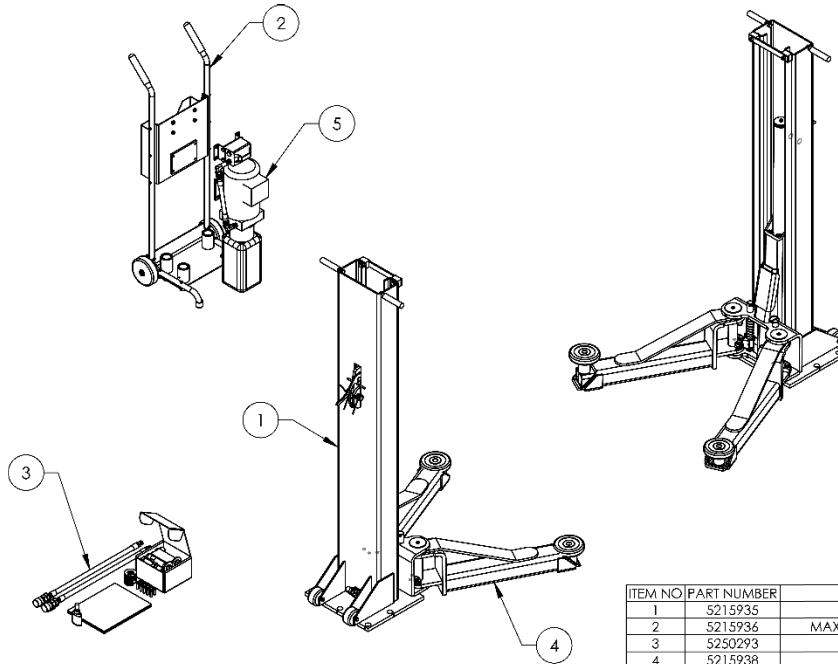

ITEM NO	PART NUMBER	DESCRIPTION	QTY	REV
1	S215935	M7K POST ASSEMBLY	2	G
2	S215936	MAX JAX POWER UNIT STAND ASSEMBLY	1	B
3	S250293	M7K PARTS BOX	1	H
4	S215938	MAX JAX ARM ASSEMBLY	4	A
5	REF	M7K POWER UNIT, 110V	1	-

DO NOT SCALE DRAWINGS		NAME:	DATE:	 1645 LEMONWOOD DR. SANTA PAULA, CA 93060
DRAWN:	TM	01/10/2022		
DIMENSIONS ARE IN MAX		CHECKED:		TITLE:
		THIRD ANGLE PROJECTION		M7K PRODUCTION LIFT, 110V
PROPRIETARY AND CONFIDENTIAL THE INFORMATION CONTAINED HEREIN IS THE PROPERTY OF BENDPAK INC. ANY REPRODUCTION OR TRANSMISSION OF THIS INFORMATION WITHOUT WRITTEN PERMISSION FROM BENDPAK INC. IS STRICTLY PROHIBITED.		SIZE:	DWG. NO.:	REV:
		A	5260671	C
			SCALE: 1:20	SHEET 1 OF 3

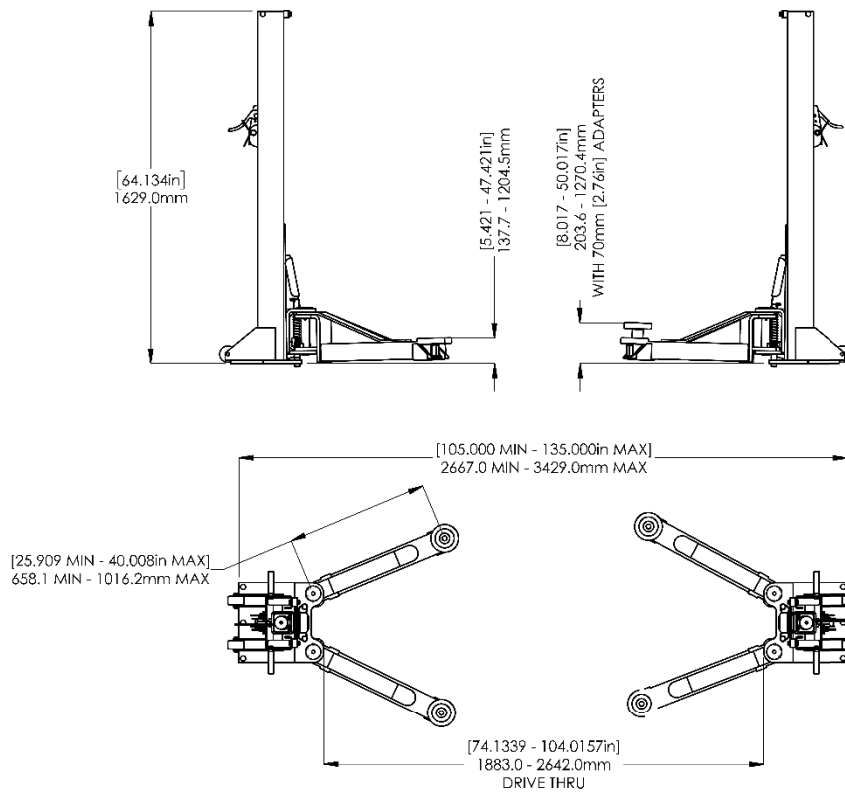

 1645 LEMONWOOD DR. SANTA PAULA, CA 93060	
TITLE: M7K PRODUCTION LIFT, 110V	
SIZE:	DWG. NO.:
A	5260671
REV:	C
SCALE: 1:20	
SHEET 2 OF 3	

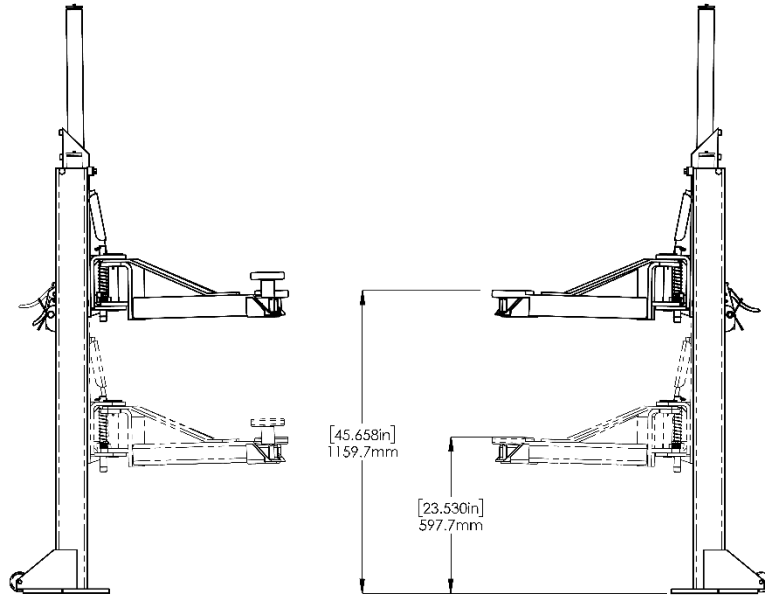

BendPak.	
1445 LEMONWOOD DR. SANTA PAULA, CA 93060	
TITLE: M7K PRODUCTION LIFT, 110V	
SIZE: DWG. NO.	REV
A 5260671	B
SCALE: 1:16 SHEET 3 OF 3	

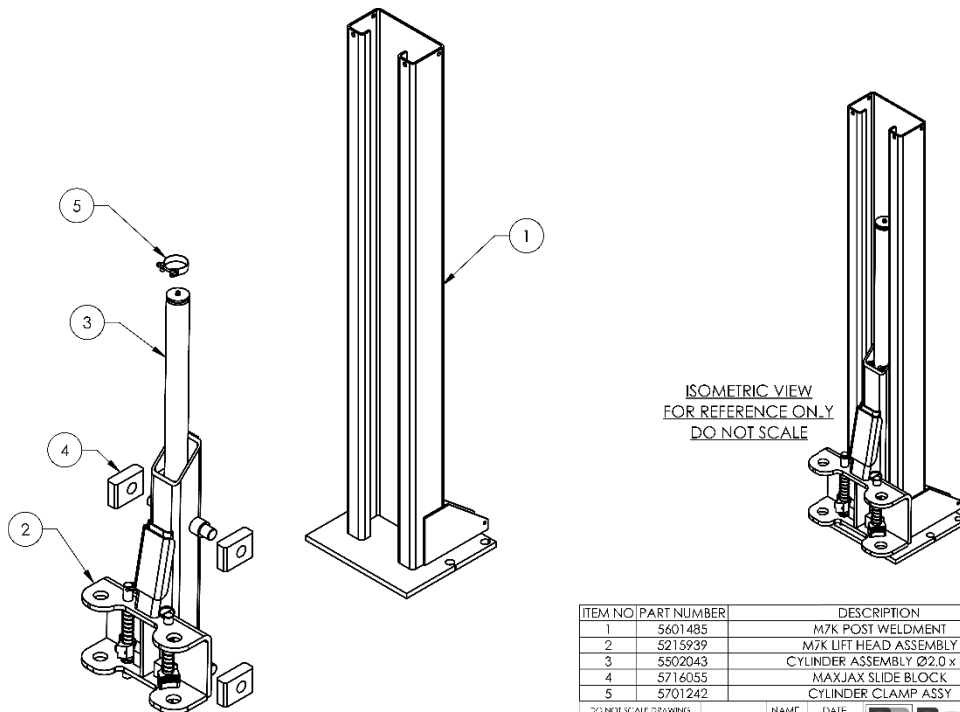

ITEM NO	PART NUMBER	DESCRIPTION	QTY	REV
1	5601485	M7K POST WELDMENT	1	E
2	5215939	M7K LIFT HEAD ASSEMBLY	1	B
3	5502043	CYLINDER ASSEMBLY Ø2.0 x 42	1	C
4	5716055	MAXJAX SLIDE BLOCK	4	A
5	5701242	CYLINDER CLAMP ASSY	1	A

DO NOT SCALE DRAWING		NAME	DATE	BendPak. 1445 LEMONWOOD DR. SANTA PAULA, CA 93060
DRAWN	OR			
CHECKED				TITLE: M7K POST ASSEMBLY
THIRD ANGLE PROJECTION				SIZE: DWG. NO.
				REV
				A 5215935
SCALE: 1:12				SHEET 1 OF 2

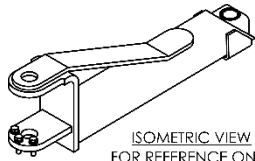

ISOMETRIC VIEW
FOR REFERENCE ONLY
DO NOT SCALE

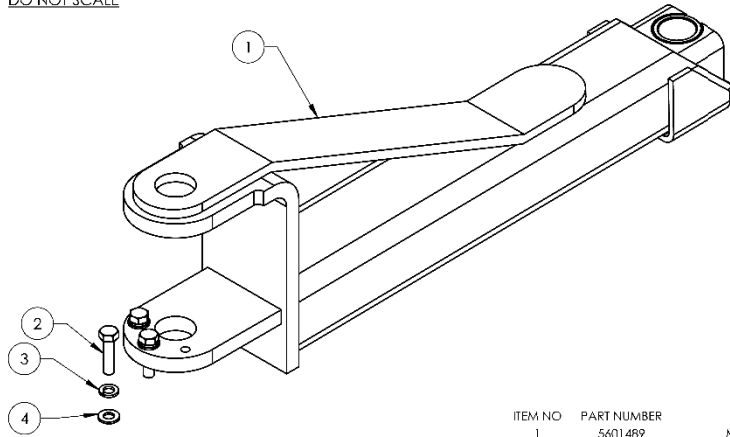

ITEM NO	PART NUMBER	DESCRIPTION	QTY	REV
1	5601489	MAXJAX ARM WELDMENT	1	A
2	5530302	HHB M10 x 1.5 x 40 FULLY THREAD	3	-
3	5545200	WASHER M10 x Ø18 SL	3	-
4	5545341	WASHER M10 x Ø20 FLAT	3	-

ISO NO: SCALE: DRAWING	NAME	DATE	BendPak 1445 LEMONWOOD DR. SANTA PAULA, CA 93060
DRAWN	OR	05/21/2020	
CHECKED	CR	07/20/2020	
THIRD ANGLE PROJECTION			TITLE
			MAXJAX ARM ASSEMBLY
SIZE DWG. NO.		REV	
A 5215938		A	
SCALE: 1:4			SHEET 1 OF 2

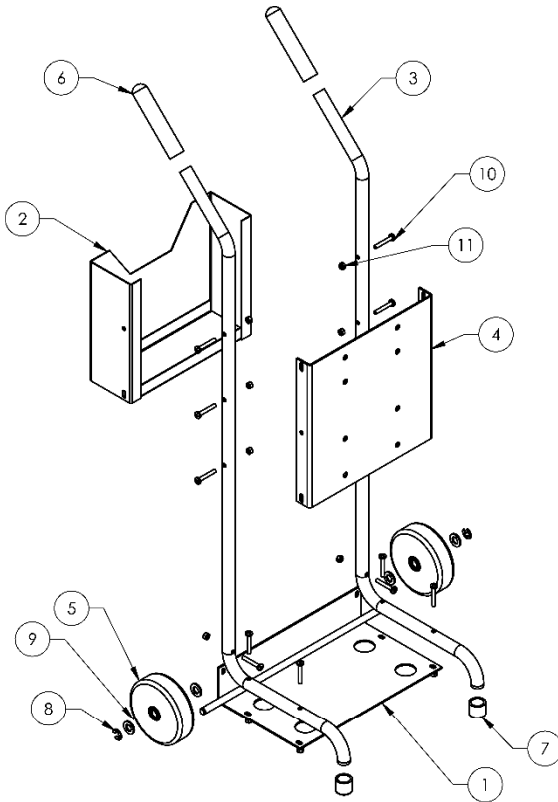

ISOMETRIC VIEW
FOR REFERENCE ONLY
DO NOT SCALE

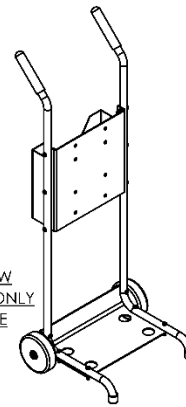

ITEM NO	PART NUMBER	DESCRIPTION	QTY	REV
1	5601535	MAX JAX BOTTOM PLATE WELDMENT, STAND	1	A
2	5601474	M6K HOSE STORAGE BOX WELDMENT	1	B
3	5755171	MAX JAX STAND HANDLE	2	B
4	5737162	MAX JAX STAND SUPPORT PLATE	1	A
5	5215970	MAX JAX HAND CART WHEEL ASSEMBLY	2	-
6	5715041	MAX JAX VINYL GRIP, Ø22 I.D.	2	A
7	5716056	MAX JAX VINYL CAP, Ø22 I.D.	2	B
8	5540113	E RING Ø1 1/2" OD TRUARC 5133-50	2	-
9	5545141	WASHER M12 x 24 FLAT CL 10.9	4	-
10	5530378	PHPS M6 x 1.0 x 40mm	12	-
11	5535357	NUT M6 x 1.0 NL	12	-

ISO NO: SCALE: DRAWING	NAME	DATE	BendPak 1445 LEMONWOOD DR. SANTA PAULA, CA 93060
DRAWN	OR	05/27/2020	
CHECKED	CR		
THIRD ANGLE PROJECTION			TITLE
			MAX JAX POWER UNIT STAND ASSEMBLY
SIZE DWG. NO.		REV	
A 5215936		B	
SCALE: 1:8			SHEET 1 OF 1

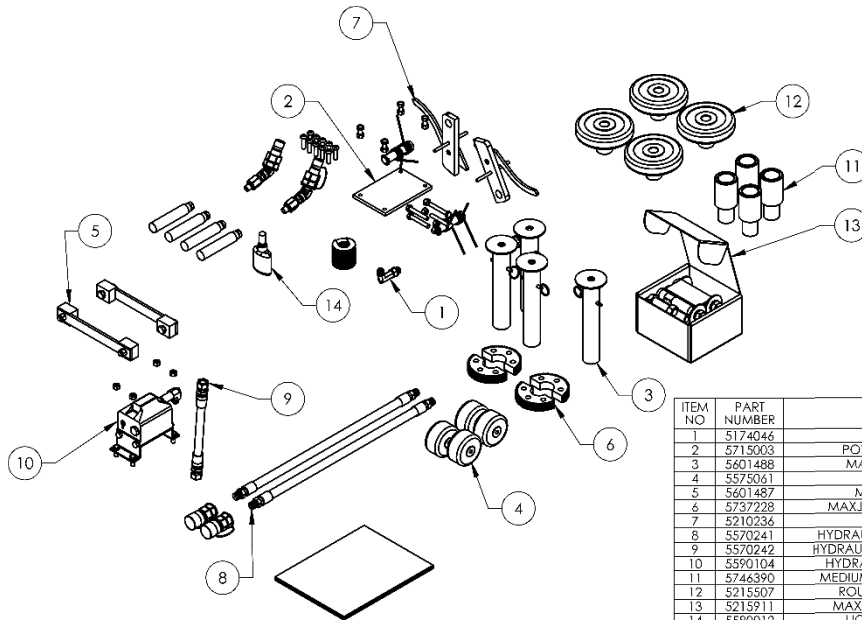

ITEM NO	PART NUMBER	DESCRIPTION	QTY	REV
1	5174046	M7K PARTS BAG	1	F
2	5715003	POWER UNIT VIBRATION DAMPENER	1	B
3	5601498	MAXJAX LIFT HEAD PIN WELDMENT	4	B
4	5575061	M7K POST WHEEL	4	-
5	5601487	MAXJAX POST STRAP ASSEMBLY	2	A
6	5737228	MAXJAX BOLT ON ARM RESTRAINT GEAR	4	A
7	5210236	MAXJAX SAFETY WELDMENT	2	B
8	5570241	HYDRAULIC HOSE ASSEMBLY Ø10 x 4405mm	2	B
9	5570242	HYDRAULIC HOSE ASSEMBLY Ø10 x 295mm DS	1	C
10	5590104	HYDRAULIC FLOW DIVIDER CAST IRON; ST	1	-
11	5746390	MEDIUM LIFT PAD EXTENSION Ø35 x 113mm	4	E
12	5215507	ROUND LIFT PAD ADAPTER ASSEMBLY	4	G
13	5215911	MAXJAX STANDARD ANCHOR BOLT KIT	1	-
14	5580012	LIQUID PTFE THREAD SEALANT 50ml	1	-
-	5900268	MAXJAX OPERATION MANUAL	1	-
-	5900304	M7K INSTALLATION MANUAL	1	-

EG 1:2 SCALE DRAWING

DRAWN OR 06/01/2020
 CHECKED CR 01/14/2022

DIMENSIONS ARE IN MM

THIRD ANGLE PROJECTION

SMILEY FACE

PROPRIETARY AND CONFIDENTIAL
 ALL RIGHTS RESERVED. THIS DRAWING IS THE PROPERTY OF BENDPAK INC. AND IS NOT TO BE REPRODUCED OR TRANSMITTED IN ANY FORM OR BY ANY MEANS, ELECTRONIC OR MECHANICAL, INCLUDING PHOTOCOPYING, RECORDING, OR BY ANY INFORMATION STORAGE AND RETRIEVAL SYSTEM.

BendPak
 745 LEMONWOOD DR.
 SANTA PAULA, CA 93060

TITLE: M7K PARTS BOX

SIZE DWG. NO. REV
 A 5250293 H

SCALE: 1:25 SHEET 1 OF 1

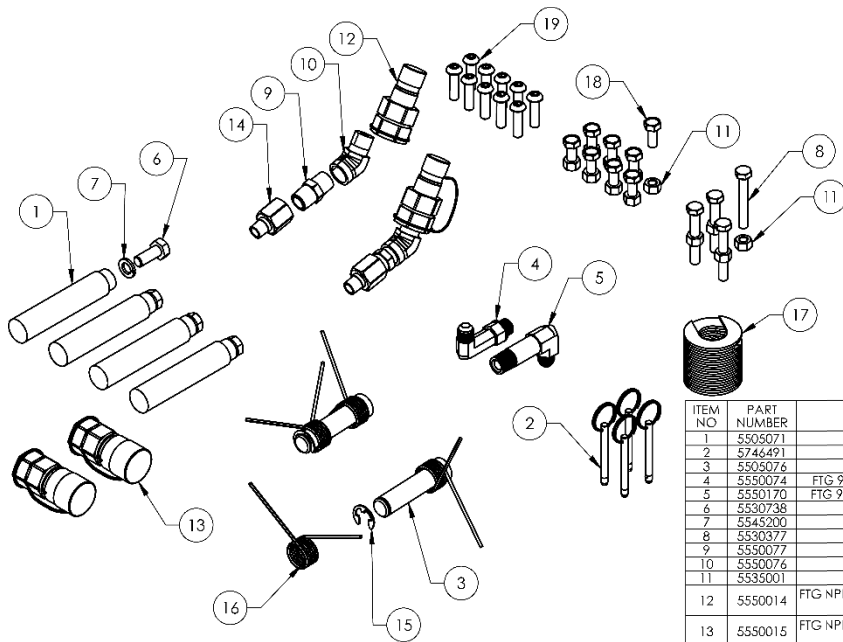

ITEM NO	PART NUMBER	DESCRIPTION	QTY	REV
1	5505071	M7K SAFETY PIN ASSEMBLY	4	C
2	5744491	MAXJAX LIFT HEAD RELEASE PIN	4	A
3	5505076	MAXJAX SAFETY CLEVIS PIN	2	A
4	5550074	FTG 90° ELB 3/8" JIC MALE x 3/8" ORB MALE, LONG	1	-
5	5550170	FTG 90° ELB 3/8" JIC MALE x 3/8" NPTF MALE, LONG	1	-
6	5530738	HNB M10 x 1.5 x 25	4	-
7	5545200	WASHER M10 x Ø18 SL	4	-
8	5530377	HNB M8 x 1.25 x 55	4	-
9	5550077	FTG -06 NPTF x -06 NPTF, HEX NIPPLE	2	-
10	5550076	FTG 45° ELB -06 NPTF x -06 NPTF	2	-
11	5535001	NUT M8 x 1.25 NL	12	-
12	5550014	FTG NPL -06 NPT F x 3/8 QUICK-CONNECTOR COUPLER MALE; NON SPILL DESIGN	2	-
13	5550015	FTG NPL -06 NPT F x 3/8 QUICK-CONNECTOR COUPLER FEMALE; NON SPILL DESIGN	2	-
14	5550209	FTG -04 NPTF x -06 NPTF, STRAIGHT EXPANDER	2	-
15	5540109	E RING Ø16mm OD DIN 6799 0160	2	-
16	5540075	R.H., 2.5 WIRE DIA., Ø20.5 x 75 LG	4	-
17	5545535	C WASHER SHIM FOR LIFTS	21	-
18	5530304	HNB M8 x 1.25 x 20mm	8	-
19	5530412	BHSK M8 x 1.25 x 30 CL110.9	10	-

EG 1:2 SCALE DRAWING

DRAWN OR 06/19/2020
 CHECKED CR 01/14/2022

DIMENSIONS ARE IN MM

THIRD ANGLE PROJECTION

SMILEY FACE

PROPRIETARY AND CONFIDENTIAL
 ALL RIGHTS RESERVED. THIS DRAWING IS THE PROPERTY OF BENDPAK INC. AND IS NOT TO BE REPRODUCED OR TRANSMITTED IN ANY FORM OR BY ANY MEANS, ELECTRONIC OR MECHANICAL, INCLUDING PHOTOCOPYING, RECORDING, OR BY ANY INFORMATION STORAGE AND RETRIEVAL SYSTEM.

BendPak
 745 LEMONWOOD DR.
 SANTA PAULA, CA 93060

TITLE: M7K PARTS BAG

SIZE DWG. NO. REV
 A 5174046 F

SCALE: 1:4 SHEET 1 OF 1

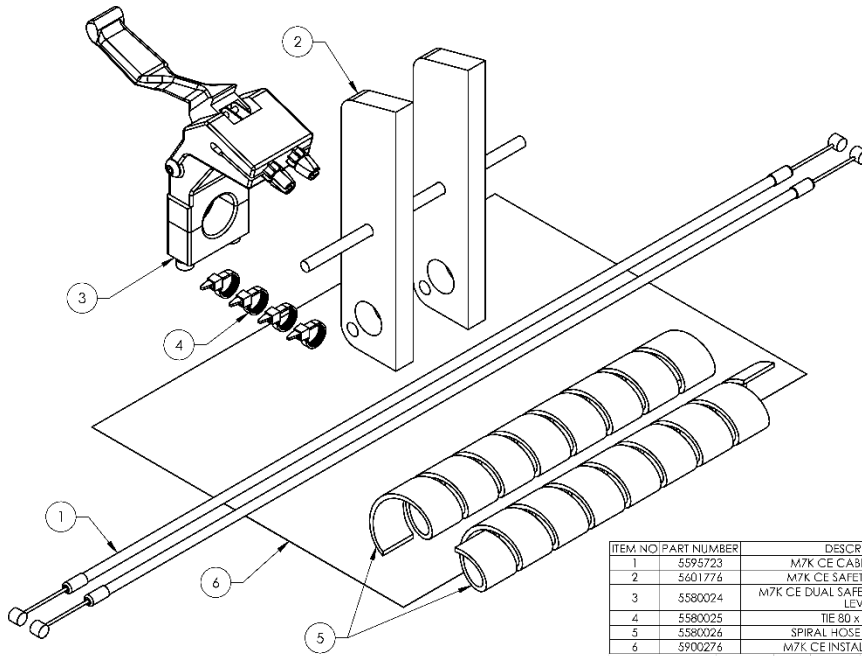

ITEM NO.	PART NUMBER	DESCRIPTION	QTY	REV
1	5595723	M7K CE CABLE ASSEMBLY	2	-
2	5601776	M7K CE SAFETY WELDMENT	2	A
3	5580024	M7K CE DUAL SAFETY CABLE RELEASE LEVER	1	-
4	5580025	TIE 80 x 2.9mm	4	-
5	5580026	SPIRAL HOSE COVER Ø25	4405mm*	-
6	5900276	M7K CE INSTALLATION SHEET	1	-

DO NOT SCALE DRAWING		NAME	DATE	
DRAWN	CA	02/16/2022		
CHECKED	OR	02/16/2022		645 LINDEN WOOD DR. SANTA FE VALLEY, CA 95660
DIMENSIONS ARE IN MM		THIRD ANGLE PROJECTION		TITLE
				M7K CE KIT
<small> PROPRIETARY AND CONFIDENTIAL THIS INFORMATION IS UNCLASSIFIED UNLESS INDICATED OTHERWISE BY THE U.S. GOVERNMENT REPRODUCTION BY ANY MEANS IS PROHIBITED WITHOUT THE WRITTEN PERMISSION OF BENDPAK INC. BENDPAK INC. </small>		SIZE	DWG. NO.	REV
		A	5210308	A
		SCALE: 1:2		SHEET 1 OF 1

Automotive Lift Institute (ALI) Store

The ALI Store is your trusted source for workplace safety!

Visit www.autolift.org/ali-store/

You probably checked the ALI's Directory of Certified Lifts (www.autolift.org/ali-directory-of-certified-lifts/) before making your most recent Lift purchase, but did you know the ALI Store (www.autolift.org/ali-store/) offers a wide variety of professional, easy-to-use, and reasonably priced training and safety materials that will make your garage a safer place to work? To find a Certified Lift Inspector in your local area, visit Directory of ALI Certified Lift Inspection Providers (www.autolift.org/find-a-certified-auto-lift-inspector/).



Lifting It Right Online Certificate Course. Make sure you and your people are lifting vehicles the right way.



ALI Lift Inspector Certification Program Registration. Become a ALI Certified Lift Inspector.

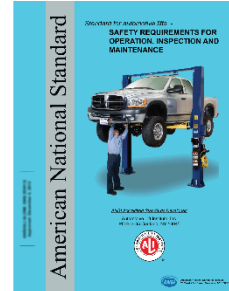

ANSI/ALI ALOIM Standard for Automotive Lifts. Safety Requirements for Operation, Inspection, and Maintenance.

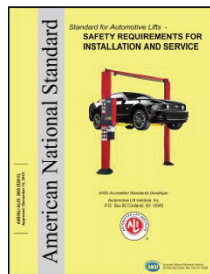

ANSI/ALI ALIS Standard. Safety Requirements for Installation and Service.



Guide to Identifying Vehicle Lifting Points for Frame-Engaging Lifts. Don't eyeball your lifting points, *know* where they are.



Lift Operator Safety Materials. Five safety documents in a single package.

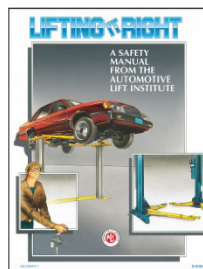

Lifting It Right. A hardcopy version of the *Lifting It Right* safety manual from the Automotive Lift Institute.



Uniform Warning Labels and Placards for 2-Posts. Labels in Mandarin, French Canadian, and Spanish are also available.



Safety Tips Card. Reminds your people of 13 key safety tips to follow daily.

Get the training and materials you need to work safely at www.autolift.org/ali-store/



1645 Lemonwood Drive
Santa Paula, CA 93060 USA
bendpak.com