



Toll Free: 1-800-579-8088 Web: www.zinko.com

MODEL

ZHP-90, ZHP-120, ZHP-150 & ZHP-180 Heavy Duty Two-Speed Hydraulic Hand Pumps

Operation & Maintenance Manual

Important Receiving Instructions

Visually inspect all components for shipping damage. Shipping damage is NOT covered by warranty. If shipping damage is found, notify carrier at once. The carrier is responsible for all repairs and replacement costs during product shipping.

Safety Information

Read and follow all **instructions, warnings, cautions** and carefully. Follow all safety precautions to avoid personal injury or property damage during system operation. **ZINKO** is not responsible for damage or injury resulting from unsafe product use, lack of maintenance, or incorrect product and/or system operation. Contact **ZINKO** when in doubt as to the safety precautions and operations. Failure to comply with the following cautions and warnings could cause equipment damage and personal injury.

Caution Remarks Used In This Manual

WARNING indicates a potential danger that requires correct procedures or practices to avoid personal injury.

CAUTION is used to indicate correct operating maintenance procedures and practices to prevent damage to or destruction of equipment or other property.

Operator Responsibility

It is the operator's responsibility to read and understand all of the following safety statements:

WARNING

1. Make sure that all system components are protected from external sources of damage, such as excessive heat, flame, moving machine parts, sharp edges, and corrosive chemicals.
2. **WEAR PROPER PERSONAL PROTECTIVE GEAR WHEN OPERATING HYDRAULIC EQUIPMENT.**
3. Always check product limitations regarding pressure ratings, load capacities, and setup requirements. The system operating pressure **MUST NOT** exceed the pressure rating of the lowest rated component in the system.
4. **NEVER** set the relief valve to a higher pressure than the maximum rated pressure of the pump. Higher settings may result in equipment damage and/or personal injury.

Installation

Connecting the Pump

1. Thread hose into pump outlet. Use 1-1/2 wraps of Teflon tape (or suitable thread sealant) on hose fitting, leaving the first complete thread free of tape to ensure that tape does not shed into the hydraulic system causing damage. Trim loose ends.
2. Install a pressure gauge in-line from the pump for added safety and better control.
3. Connect the hose(s) to your cylinder or tool.

NOTE: **For single-acting cylinders:** Connect one hose from the pump to the cylinder.

For double-acting cylinders: Connect two hoses. Connect one from the pressure port of the pump to the pressure port of the cylinder. Connect another hose from the retract port of the pump to the retract port of the cylinder.

Pump Venting

Vented pumps provide slightly better performance. For pumps with a nylon reservoir, turn vent/fill cap 1/4 turn counter-clockwise to vent. Close vent prior to transporting pump to prevent oil leakage.

NOTE: When operating the pump in the vertical position, the hose end must be pointed down or the pump will pick up air and will not build pressure properly.

Operation

Before Using the Pump

1. Check all system fittings and connections to make sure they are tight and leak-free.
2. Check oil level in reservoir before operating pump. See *Maintenance* on page 2.

WARNING a) **Never add extensions to the pump handle.** Extensions cause unstable pump operation.
b) In certain situations the pump handle can "**kick back**". Always keep your body to the side of the pump and away from the line of force.

NOTE: To reduce handle effort at high pressure, take short strokes. Maximum leverage is obtained in the last 5 degrees of the stroke.

Zinko Hydraulic Jack

Model: ZHP-90, ZHP-120, ZHP-150 & ZHP-180

Using Two-Speed Pumps

These pumps provide two-stage flow. Under no load, the pump operates in the high flow stage for rapid advance. When the load is contracted, the pump automatically shifts to the second stage for building pressure. When pump pressure reaches approximately 200 psi, you must momentarily stop pumping and raise the handle to shift to the high pressure stage. After the pump shifts, pumping takes less effort.

NOTE: For best performance, operate handle at moderate speed during the high flow first stage. Rapid handle speed in the first stage will prevent the pump from delivering a full volume of oil.

Single-Acting Applications with Release Valve

1. Close the release valve by turning clockwise.

CAUTION Close release valve finger tight **ONLY**. Using tools on release valve can damage it and cause the pump to malfunction.

2. Operate pump handle to deliver hydraulic power to the system. Pressure will be maintained until release valve is opened.
3. Open release valve (turn counterclockwise) to release pressure allowing oil to flow back to the reservoir.

Single-Acting Applications with 3-Way Position Manual Valve

1. Shift valve handle to position 1.
2. Operate pump handle to deliver hydraulic power to the system. Pressure will be maintained until the valve is shifted.
3. To allow oil to return to the reservoir, shift valve handle to position 2.

Relief Valve Adjustment

All pumps contain a factory set relief valve to prevent over pressurization of the system. Lower pressure settings can be obtained: contact your Authorized Service Center for more information.

Bleeding Air From the System

Air Removal

Removing air from the hydraulic system will help the cylinder to advance and retract smoothly. Air can accumulate in the hydraulic system during the initial setup, or after prolonged use, which causes the cylinder to respond slowly or in an unstable manner.

To Remove Air

1. Position the cylinder at a lower level than the pump and turn the cylinder rod down.
2. With no load on the system and the pump vented, extend and retract the cylinder several times. Air will be released into the pump reservoir. Follow the fluid level instructions for your reservoir type to release the air from the reservoir and top off the fluid supply.

Maintenance

Use only **ZINKO** hydraulic oil with these pumps to promote long pump life and protect your warranty. **ZINKO** seal kits are available for some hand pumps. Contact your **ZINKO** representative for more information on these products and/or other products.

Adding Oil to the Pump

WARNING Check oil level regularly. Always add oil with cylinders fully retracted (extended if pull cylinders) or the system will contain more oil than the reservoir can hold.

1. Remove vent/fill cap from reservoir.
2. Fill reservoir only to level mark shown on pump.
3. Remove air from system if necessary. Recheck oil level after removing air.
4. Return vent/fill cap to proper position.

NOTE: Non-vented hand pumps require air completely filled or a vacuum will form preventing oil from flowing out of the pump.

Keeping Oil Lines Clean

When coupler halves are disconnected, always screw on dust caps. Use every precaution to guard unit from dirt entering the system because foreign matter may cause pump, cylinder, or valve failure.

Lubricating the Pump

To extend pump life and improve performance, lubricate the beam pin, cross pin, and piston head and close release valve.

Changing the Oil

1. Drain all oil and refill with clean **ZINKO** oil every 12 months. If pump is used in dirty environments, change oil more often. Be sure to dispose of used oil properly.
2. Remove vent/fill cap or plug from reservoir.
3. Tilt pump to drain out old oil.
4. Replace the vent/fill cap or plug.
5. Regularly use roller bearing grease.

Zinko Hydraulic Jack

Model: ZHP-90, ZHP-120, ZHP-150 & ZHP-180

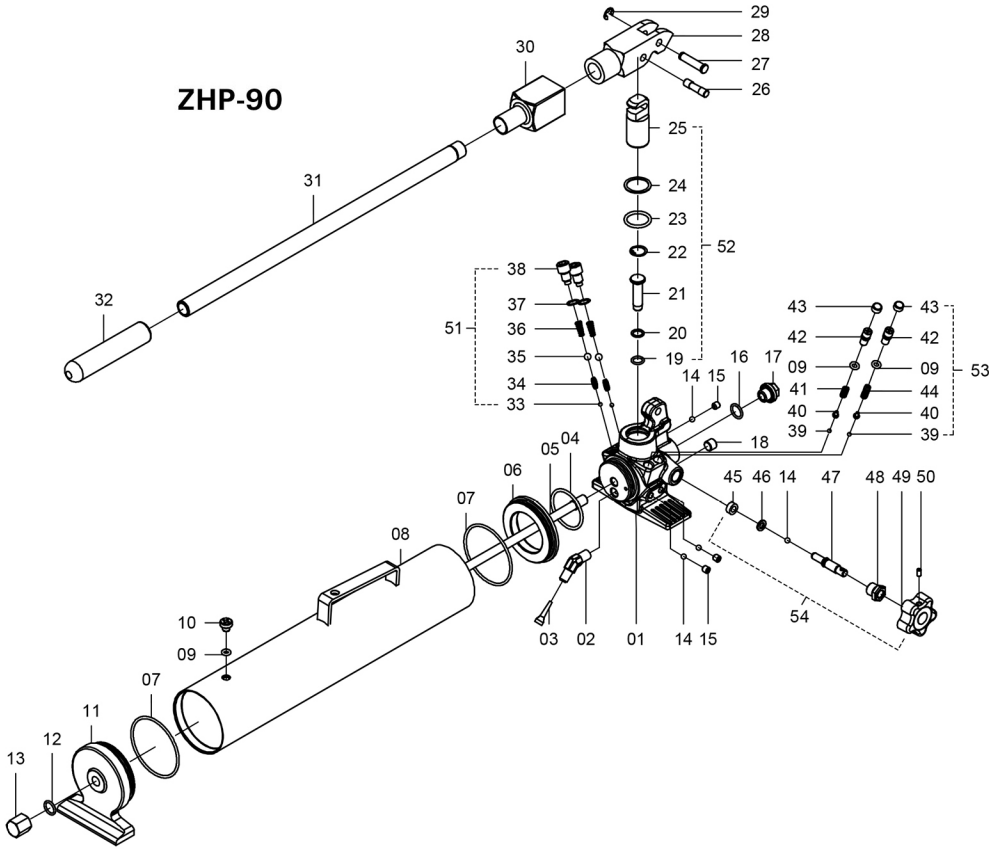

No.	Description
1	Pump Housing
2	45° Elbow
3	Oil Filter
4	O-Ring*
5	Screw
6	Head Base
7	O-Ring*
8	Reservoir
9	O-Ring*
10	Air Release Screw
11	Tail Base
12	O-Ring*
13	Nipple
14	Check Ball
15	Set Screw
16	O-Ring*
17	Screw
18	Screw
19	O-Ring*
20	Backup Ring*
21	Pump Piston
22	Snap Ring*
23	O-Ring*
24	Backup Ring*
25	Pump Piston
26	Piston Pin
27	Yoke Pin
28	Yoke

No.	Description
29	Retaining Pin
30	Yoke Cover
31	Handle
32	Handle Grip
33	Check Ball
34	Spring
35	Check Ball
36	Spring
37	Washer
38	Valve Cover Screw
39	Check Ball
40	Spring End Cap
41	Short Sep. Spring
42	Overload Cover Spring
43	Cap
44	Long Sep. Spring
45	Oil Seal
46	Washer
47	Release Nut
48	Release Valve Screw
49	Release Knob
50	Set Screw
51	Pressure Valve Kit
52	Plunger Kit
53	Relief Valve Pressure Kit
54	Release Valve Kit
55	Repair Kit (*)

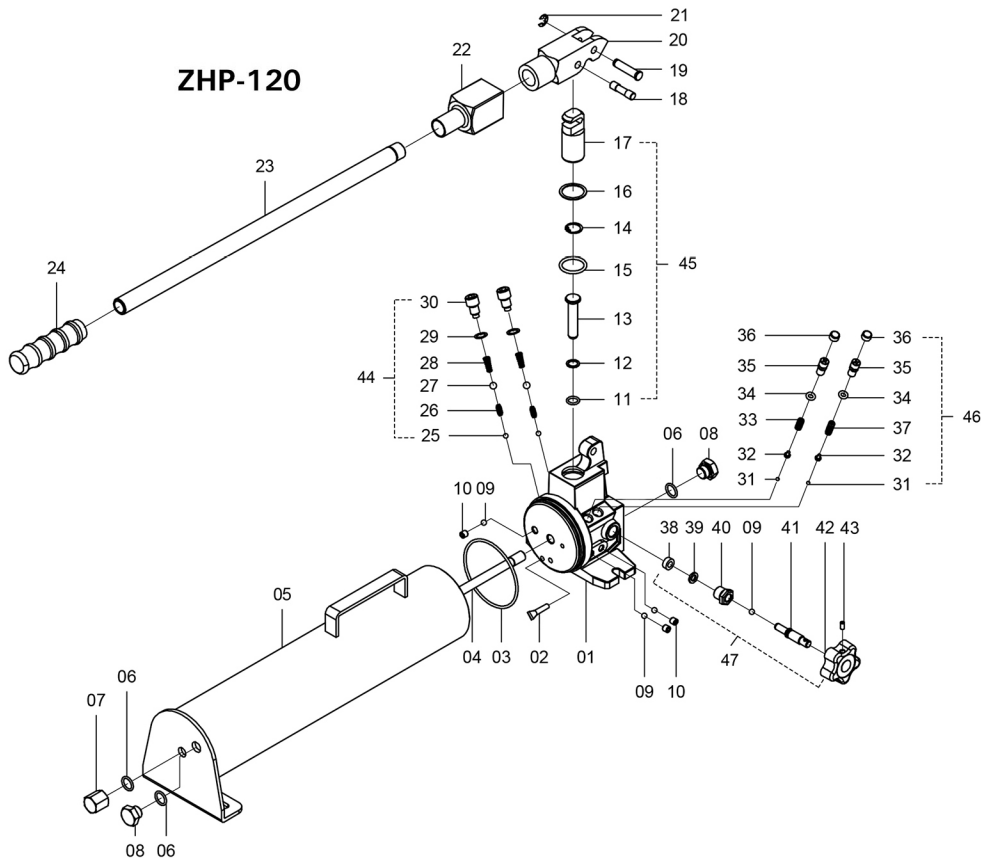

No.	Description
1	Pump Housing
2	Oil Filter
3	O-Ring*
4	Screw
5	Reservoir
6	O-Ring*
7	Nipple
8	Screw
9	Check Ball
10	Set Screw
11	O-Ring*
12	Backup Ring*
13	Pump Piston
14	Snap Ring*
15	O-Ring*
16	Backup Ring*
17	Pump Piston
18	Piston Pin
19	Yoke Pin
20	Yoke
21	Retaining Pin
22	Yoke Cover
23	Handle
24	Handle Grip

No.	Description
25	Check Ball
26	Spring
27	Check Ball
28	Spring
29	Washer
30	Valve Cover Screw
31	Check Ball
32	Spring End Cap
33	Short Sep. Spring
34	O-Ring*
35	Overload Cover Spring
36	Cap
37	Long Sep. Spring
38	Oil Seal
39	Washer
40	Release Nut
41	Release Valve Screw
42	Release Knob
43	Set Screw
44	Pressure Valve Kit
45	Plunger Kit
46	Relief Valve Pressure Kit
47	Release Valve Kit
48	Repair Kit (*)

Zinko Hydraulic Jack

Model: ZHP-90, ZHP-120, ZHP-150 & ZHP-180

ZHP-150

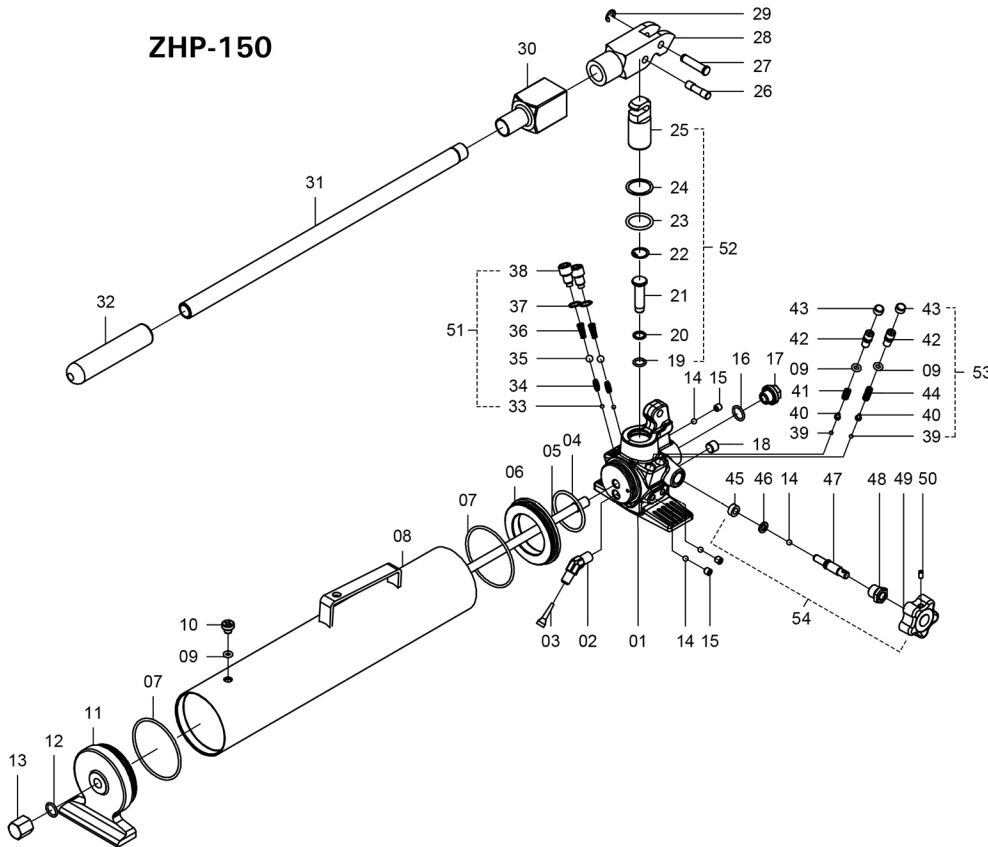

No.	Description
1	Pump Housing
2	45° Elbow
3	Oil Filter
4	O-Ring*
5	Screw
6	Head Base
7	O-Ring*
8	Reservoir
9	O-Ring*
10	Air Release Screw
11	Tail Base
12	O-Ring*
13	Nipple
14	Check Ball
15	Set Screw
16	O-Ring*
17	Screw
18	Screw
19	O-Ring*
20	Backup Ring*
21	Pump Piston
22	Snap Ring*
23	O-Ring*
24	Backup Ring*
25	Pump Piston
26	Piston Pin
27	Yoke Pin
28	Yoke

No.	Description
29	Retaining Pin
30	Yoke Cover
31	Handle
32	Handle Grip
33	Check Ball
34	Spring
35	Check Ball
36	Spring
37	Washer
38	Valve Cover Screw
39	Check Ball
40	Spring End Cap
41	Short Sep. Spring
42	Overload Cover Spring
43	Cap
44	Long Sep. Spring
45	Oil Seal
46	Washer
47	Release Nut
48	Release Valve Screw
49	Release Knob
50	Set Screw
51	Pressure Valve Kit
52	Plunger Kit
53	Relief Valve Pressure Kit
54	Release Valve Kit
55	Repair Kit (*)

ZHP-180

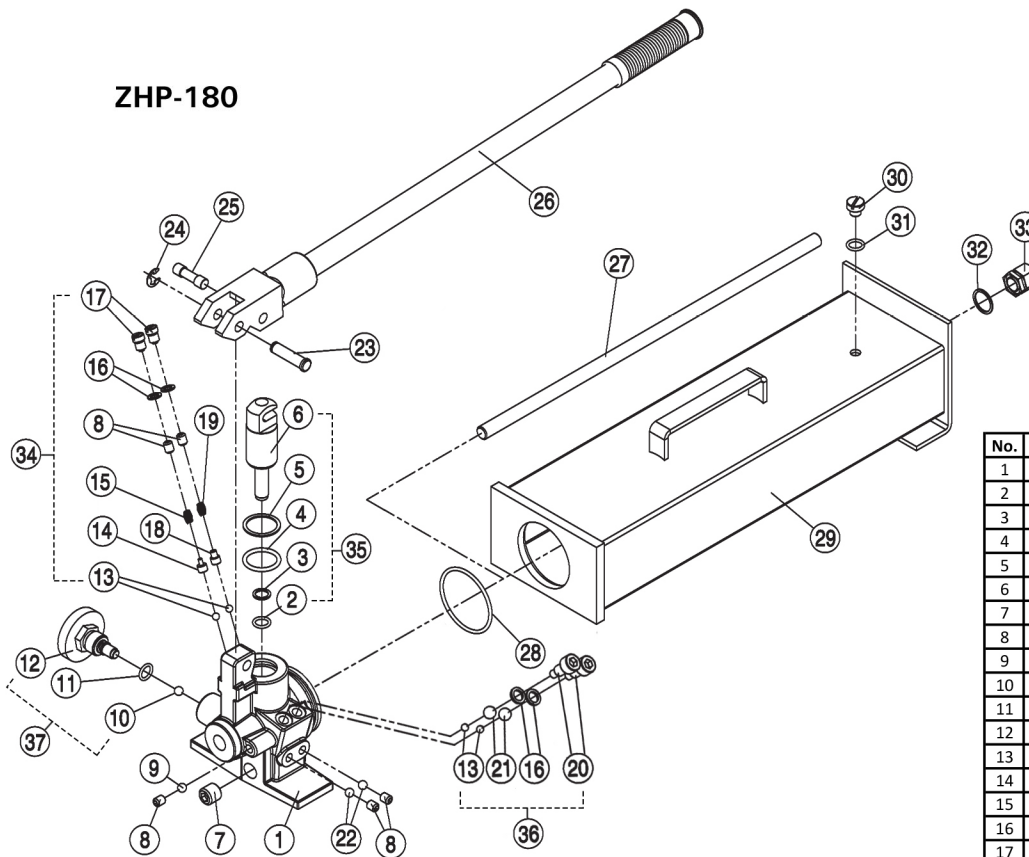

No.	Description
1	Pump Housing
2	O-Ring*
3	Backup Ring*
4	O-Ring*
5	Backup Ring*
6	Pump Piston
7	Screw
8	Screw
9	Steel Ball
10	Steel Ball
11	O-Ring*
12	Release Valve
13	Steel Ball
14	Bearing
15	Spring
16	Washer
17	Screw
18	Bearing
19	Steel Ball

No.	Description
20	Cover Screw
21	Steel Ball
22	Steel Ball
23	Pin
24	E Ring
25	Pin
26	Handle
27	Screw
28	O-Ring*
29	Reservoir
30	Fill Plug
31	O-Ring*
32	Gasket
33	Nipple
34	Pressure Valve Kit
35	Plunger Kit
36	Relief Valve Pressure Kit
37	Release Valve Kit
38	Repair Kit (*)

Zinko Hydraulic Jack

Model: **ZHP-90, ZHP-120, ZHP-150 & ZHP-180**

Troubleshooting

PROBLEM	POSSIBLE CAUSE	SOLUTION
Cylinder does not advance, advances slowly, or advances in spurts.	Oil level in pump reservoir is low.	Add oil according to <i>Maintenance</i> section (page 2).
	Release valve is open.	Close the release valve.
	Loose hydraulic coupler.	Check that all couplers are fully tightened.
	Load is too heavy.	Do not attempt to lift more than rated tonnage.
	Air trapped in system.	Remove air according to instructions on page 2.
	Cylinder plunger binding.	Check for damage to the cylinder. Have cylinder serviced by a qualified hydraulic technician.
Cylinder advances, but does not hold pressure.	Leaking connection.	Check that all connection are tight and leak free.
	Leaking seals.	Locate leak(s) and have equipment serviced by a qualified hydraulic technician.
	Internal leakage in pump.	Locate leak(s) and have equipment serviced by a qualified hydraulic technician.
Cylinder does not retract, retracts part way, or retracts more slowly than normal.	Release valve close.	Open release valve.
	Pump reservoir is overfilled	Drain oil level to full mark. See page instructions for adding oil.
	Loose hydraulic coupler.	Check that all couplers are fully tightened.
	Air trapped in system.	Remove air according to instructions on page 2.
	Hose I.D. too narrow.	Use larger diameter hydraulic hose.
	Cylinder retraction spring broken or other cylinder damage.	Have cylinder serviced by a qualified service technician.

If the above procedures do not correct the problem, contact your nearest **ZINKO** service facility. When submitting any jack or equipment to be repaired, be sure to state the nature of the problem and indicate whether an estimate of the repair cost is needed.



ZINKO HYDRAULIC JACK

PO Box 4903, Ontario, CA 91761

Toll Free: 1-800-579-8088

www.zinkojack.com

Phone: (909) 230-4100

Fax: (909) 230-4137