



OPERATOR'S MANUAL

Metal Working



SWIVEL HEAD HORIZONTAL BAND SAW MODEL: BS-712MS

Baileigh Industrial
P.O. Box 531
Manitowoc, WI 54221-0531
Phone: 920.684.4990
Fax: 920.684.3944
sales@baileigh.com

REPRODUCTION OF THIS MANUAL IN ANY FORM WITHOUT WRITTEN APPROVAL OF BAILEIGH INDUSTRIAL IS PROHIBITED. Baileigh Industrial does not assume and hereby disclaims any liability for any damage or loss caused by an omission or error in this Operator's Manual, resulting from accident, negligence, or other occurrence.



Table of Contents

THANK YOU & WARRANTY	1
INTRODUCTION.....	3
GENERAL NOTES.....	3
SAFETY INSTRUCTIONS	4
SAFETY PRECAUTIONS	6
Dear Valued Customer:.....	6
TECHNICAL SPECIFICATIONS	9
TECHNICAL SUPPORT	9
UNPACKING AND CHECKING CONTENTS.....	10
TRANSPORTING AND LIFTING	13
INSTALLATION.....	13
OVERALL DIMENSIONS.....	15
GETTING TO KNOW YOUR MACHINE	16
ASSEMBLY AND SET UP	18
ELECTRICAL.....	22
BEFORE EACH USE	24
Whenever Saw is Running	24
Breaking in a Band Saw Blade	25
Metal Chip Indicators.....	25
Blade Terminology.....	26
Width of Blade	26
Length of Blade	26
Blade structure	27
Blade type	27
SETS	28
BLADE CARE	29
CHOOSING A SAW BLADE.....	29
BLADE BREAKAGE.....	31
MATERIAL SELECTION.....	31
MACHINE ADJUSTMENTS	32
Blade Guide Adjustment.....	32
Swivel Saw Head.....	32
Adjusting Automatic Shut-off	33
Adjusting Blade Tension	34
Adjusting Bow Weight.....	34
Changing the Blade	35
Adjusting Blade Guide Bearings	36
Adjusting Blade Tracking.....	37
Changing Blade Speed.....	38
Vertical Cutting	38
PRIOR TO OPERATION.....	39
Hydraulic Feed Selector	39
OPERATION.....	40



LUBRICATION AND MAINTENANCE	41
Accessing and Cleaning the Coolant System	42
Gearbox Maintenance	43
Oils for Lubricating Coolant	43
Storing Machine for Extended Period of Time	43
PARTS DIAGRAM - A	44
PARTS DIAGRAM – B	45
Parts List For “A” And “B”	46
ELECTRICAL COMPONENTS	52
WIRING DIAGRAM	52
ELECTRICAL SCHEMATIC	53
TROUBLESHOOTING	54



THANK YOU & WARRANTY

Thank you for your purchase of a machine from Baileigh Industrial. We hope that you find it productive and useful to you for a long time to come.

Inspection & Acceptance. Buyer shall inspect all Goods within ten (10) days after receipt thereof. Buyer's payment shall constitute final acceptance of the Goods and shall act as a waiver of the Buyer's rights to inspect or reject the goods unless otherwise agreed. If Buyer rejects any merchandise, Buyer must first obtain a Returned Goods Authorization ("RGA") number before returning any goods to Seller. Goods returned without an RGA will be refused. Seller will not be responsible for any freight costs, damages to goods, or any other costs or liabilities pertaining to goods returned without a RGA. Seller shall have the right to substitute a conforming tender. Buyer will be responsible for all freight costs to and from Buyer and repackaging costs, if any, if Buyer refuses to accept shipment. If Goods are returned in unsalable condition, Buyer shall be responsible for full value of the Goods. Buyer may not return any special-order Goods. Any Goods returned hereunder shall be subject to a restocking fee equal to 30% of the invoice price.

Specifications. Seller may, at its option, make changes in the designs, specifications or components of the Goods to improve the safety of such Goods, or if in Seller's judgment, such changes will be beneficial to their operation or use. Buyer may not make any changes in the specifications for the Goods unless Seller approves of such changes in writing, in which event Seller may impose additional charges to implement such changes.

Limited Warranty. Seller warrants to the original end-user that the Goods manufactured or provided by Seller under this Agreement shall be free of defects in material or workmanship for a period of twelve (12) months from the date of purchase, provided that the Goods are installed, used, and maintained in accordance with any instruction manual or technical guidelines provided by the Seller or supplied with the Goods, if applicable. The original end-user must give written notice to Seller of any suspected defect in the Goods prior to the expiration of the warranty period. The original end-user must also obtain a RGA from Seller prior to returning any Goods to Seller for warranty service under this paragraph. Seller will not accept any responsibility for Goods returned without a RGA. The original end-user shall be responsible for all costs and expenses associated with returning the Goods to Seller for warranty service. In the event of a defect, Seller, at its sole option, shall repair or replace the defective Goods or refund to the original end-user the purchase price for such defective Goods. Goods are not eligible for replacement or return after a period of 10 days from date of receipt. The foregoing warranty is Seller's sole obligation, and the original end-user's exclusive remedy, with regard to any defective Goods. This limited warranty does not apply to: (a) die sets, tooling, and saw blades; (b) periodic or routine maintenance and setup, (c) repair or replacement of the Goods due to normal wear and tear, (d) defects or damage to the Goods resulting from misuse, abuse, neglect, or accidents, (f) defects or damage to the Goods resulting from improper or unauthorized alterations, modifications, or changes; and (f) any Goods that has not been installed and/or maintained in accordance with the instruction manual or technical guidelines provided by Seller.

EXCLUSION OF OTHER WARRANTIES. THE FOREGOING LIMITED WARRANTY IS IN LIEU OF ALL OTHER WARRANTIES, EXPRESS OR IMPLIED. ANY AND ALL OTHER EXPRESS, STATUTORY OR IMPLIED WARRANTIES, INCLUDING BUT NOT LIMITED TO, ANY WARRANTY OF MERCHANTABILITY OR FITNESS FOR ANY PARTICULAR PURPOSE ARE EXPRESSLY DISCLAIMED. NO WARRANTY IS MADE WHICH EXTENDS BEYOND THAT WHICH IS EXPRESSLY CONTAINED HEREIN.

Limitation of Liability. IN NO EVENT SHALL SELLER BE LIABLE TO BUYER OR ANY OTHER PARTY FOR ANY INCIDENTAL, CONSEQUENTIAL OR SPECIAL DAMAGES (INCLUDING, WITHOUT LIMITATION, LOST PROFITS OR DOWN TIME) ARISING FROM OR IN MANNER CONNECTED WITH THE GOODS, ANY BREACH BY SELLER OR ITS AGENTS OF THIS AGREEMENT, OR ANY OTHER CAUSE WHATSOEVER, WHETHER BASED ON CONTRACT, TORT OR ANY OTHER THEORY OF LIABILITY. BUYER'S REMEDY WITH RESPECT TO ANY CLAIM ARISING UNDER THIS AGREEMENT IS STRICTLY LIMITED TO NO MORE THAN THE AMOUNT PAID BY THE BUYER FOR THE GOODS.



Force Majeure. Seller shall not be responsible for any delay in the delivery of, or failure to deliver, Goods due to causes beyond Seller's reasonable control including, without limitation, acts of God, acts of war or terrorism, enemy actions, hostilities, strikes, labor difficulties, embargoes, non-delivery or late delivery of materials, parts and equipment or transportation delays not caused by the fault of Seller, delays caused by civil authorities, governmental regulations or orders, fire, lightening, natural disasters or any other cause beyond Seller's reasonable control. In the event of any such delay, performance will be postponed by such length of time as may be reasonably necessary to compensate for the delay.

Installation. If Buyer purchases any Goods that require installation, Buyer shall, at its expense, make all arrangements and connections necessary to install and operate the Goods. Buyer shall install the Goods in accordance with any Seller instructions and shall indemnify Seller against any and all damages, demands, suits, causes of action, claims and expenses (including actual attorneys' fees and costs) arising directly or indirectly out of Buyer's failure to properly install the Goods.

Work By Others; Safety Devices. Unless agreed to in writing by Seller, Seller has no responsibility for labor or work performed by Buyer or others, of any nature, relating to design, manufacture, fabrication, use, installation or provision of Goods. Buyer is solely responsible for furnishing and requiring its employees and customers to use all safety devices, guards and safe operating procedures required by law and/or as set forth in manuals and instruction sheets furnished by Seller. Buyer is responsible for consulting all operator manuals, ANSI or comparable safety standards, OSHA regulations and other sources of safety standards and regulations applicable to the use and operation of the Goods.

Remedies. Each of the rights and remedies of Seller under this Agreement is cumulative and in addition to any other or further remedies provided under this Agreement or at law or equity.

Attorney's Fees. In the event legal action is necessary to recover monies due from Buyer or to enforce any provision of this Agreement, Buyer shall be liable to Seller for all costs and expenses associated therewith, including Seller's actual attorney fees and costs.

Governing Law/Venue. This Agreement shall be construed and governed under the laws of the State of Wisconsin, without application of conflict of law principles. Each party agrees that all actions or proceedings arising out of or in connection with this Agreement shall be commenced, tried, and litigated only in the state courts sitting in Manitowish County, Wisconsin or the U.S. Federal Court for the Eastern District of Wisconsin. Each party waives any right it may have to assert the doctrine of "forum non conveniens" or to object to venue to the extent that any proceeding is brought in accordance with this section. Each party consents to and waives any objection to the exercise of personal jurisdiction over it by courts described in this section. Each party waives to the fullest extent permitted by applicable law the right to a trial by jury.

Summary of Return Policy.

- 10 Day acceptance period from date of delivery. Damage claims and order discrepancies will not be accepted after this time.
- You must obtain a Baileigh Industrial issued RGA number PRIOR to returning any materials.
- Returned materials must be received at Baileigh Industrial in new condition and in original packaging.
- Altered items are not eligible for return.
- Buyer is responsible for all shipping charges.
- A 30% re-stocking fee applies to all returns.

Baileigh Industrial makes every effort to ensure that our posted specifications, images, pricing and product availability are as correct and timely as possible. We apologize for any discrepancies that may occur. Baileigh Industrial reserves the right to make any and all changes deemed necessary in the course of business including but not limited to pricing, product specifications, quantities, and product availability.

For Customer Service & Technical Support:

Please contact one of our knowledgeable Sales and Service team members at: (920) 684-4990 or e-mail us at Baileigh-Sales@jpwindustries.com



INTRODUCTION

The quality and reliability of the components assembled on a Baileigh Industrial machine guarantee near perfect functioning, free from problems, even under the most demanding working conditions. However, if a situation arises, refer to the manual first. If a solution cannot be found, contact the distributor where you purchased our product. Make sure you have the serial number and production year of the machine (stamped on the nameplate). For replacement parts refer to the assembly numbers on the parts list drawings.

Our technical staff will do their best to help you get your machine back in working order.

In this manual you will find: (when applicable)

- Safety procedures
- Correct installation guidelines
- Description of the functional parts of the machine
- Capacity charts
- Setup and start-up instructions
- Machine operation
- Scheduled maintenance
- Parts lists

GENERAL NOTES

After receiving your equipment remove the protective container. Do a complete visual inspection, and if damage is noted, **photograph it for insurance claims** and contact your carrier at once, requesting inspection. Also contact Baileigh Industrial and inform them of the unexpected occurrence. Temporarily suspend installation.

Take necessary precautions while loading / unloading or moving the machine to avoid any injuries.

Your machine is designed and manufactured to work smoothly and efficiently. Following proper maintenance instructions will help ensure this. Try and use original spare parts, whenever possible, and most importantly; **DO NOT** overload the machine or make any modifications.



Note: *This symbol refers to useful information throughout the manual.*



IMPORTANT

PLEASE READ THIS OPERATORS MANUAL CAREFULLY

It contains important safety information, instructions, and necessary operating procedures. The continual observance of these procedures will help increase your production and extend the life of the equipment.



SAFETY INSTRUCTIONS

LEARN TO RECOGNIZE SAFETY INFORMATION

This is the safety alert symbol. When you see this symbol on your machine or in this manual, **BE ALERT TO THE POTENTIAL FOR PERSONAL INJURY!**



Follow recommended precautions and safe operating practices.

UNDERSTAND SIGNAL WORDS

A signal word – **DANGER**, **WARNING**, or **CAUTION** – is used with the safety alert symbol. **NOTICE**, which is not related to personal injury, is used without a symbol.

DANGER: Indicates a hazardous situation which, if not avoided, will result in death or serious injury.

WARNING: Indicates a hazardous situation which, if not avoided, could result in death or serious injury.

CAUTION: Indicates a hazardous situation which, if not avoided, could result in minor or moderate injury.

NOTICE: Indicates a situation which, if not avoided, could result in property damage.

DANGER

WARNING

CAUTION

NOTICE



SAVE THESE INSTRUCTIONS.
Refer to them often and use them to instruct others.



PROTECT EYES

Wear safety glasses or suitable eye protection when working on or around machinery.

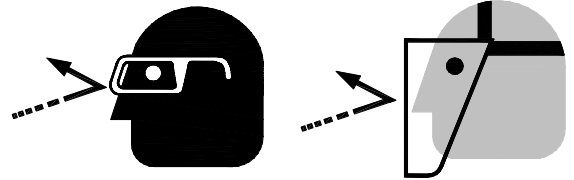

PROTECT AGAINST NOISE

Prolonged exposure to loud noise can cause impairment or loss of hearing. Wear suitable hearing protective devices such as ear muffs or earplugs to protect against objectionable or uncomfortable loud noises.

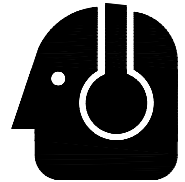

BEWARE OF CUT AND PINCH POINTS

Moving saw blade may result in loss of fingers or limb. **DO NOT** operate with guard removed. **Follow lockout/tagout procedures before servicing.**

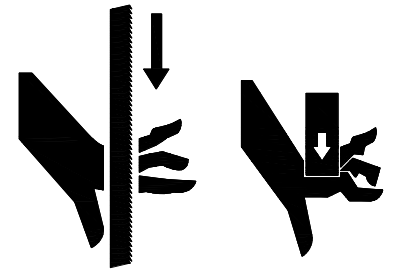

EMERGENCY STOP BUTTON

In the event of incorrect operation or dangerous conditions, the machine can be stopped immediately by pressing the **E-STOP** button. Twist the emergency stop button clockwise (cw) to reset.
Note: Resetting the E-Stop will not start the machine.



CALIFORNIA PROPOSITION 65

WARNING: Cancer and Reproductive Harm.
www.P65Warnings.ca.gov





SAFETY PRECAUTIONS



Metal working can be dangerous if safe and proper operating procedures are not followed. As with all machinery, there are certain hazards involved with the operation of the product. Using the machine with respect and caution will considerably lessen the possibility of personal injury. However, if normal safety precautions are overlooked or ignored, personal injury to the operator may result.

Safety equipment such as guards, hold-downs, safety glasses, dust masks and hearing protection can reduce your potential for injury. But even the best guard will not make up for poor judgment, carelessness or inattention. **Always use common sense** and exercise **caution** in the workshop. If a procedure feels dangerous, don't try it.

REMEMBER: Your personal safety is your responsibility.



WARNING: FAILURE TO FOLLOW THESE RULES MAY RESULT IN SERIOUS PERSONAL INJURY

Dear Valued Customer:

- All Baileigh Industrial machines should be used only for their intended use.
- Baileigh Industrial does not recommend or endorse making any modifications or alterations to a Baileigh Industrial machine. Modifications or alterations to a machine may pose a substantial risk of injury to the operator or others and may do substantial damage to the machine.
- Any modifications or alterations to a Baileigh Industrial machine will invalidate the machine's warranty.

PLEASE ENJOY YOUR BAILEIGH INDUSTRIAL MACHINE!PLEASE ENJOY IT SAFELY!

1. **FOR YOUR OWN SAFETY, READ INSTRUCTION MANUAL BEFORE OPERATING THE MACHINE.** Learn the machine's application and limitations as well as the specific hazards.
2. **Only trained and qualified personnel can operate this machine.**
3. **Make sure guards are in place and in proper working order before operating machinery.**
4. **Remove any adjusting tools.** Before operating the machine, make sure any adjusting tools have been removed.
5. **Keep work area clean.** Cluttered areas invite injuries.



6. **Overloading machine.** By overloading the machine, you may cause injury from flying parts. **DO NOT** exceed the specified machine capacities.
7. **Dressing material edges.** Always chamfer and deburr all sharp edges.
8. **Do not force tool.** Your machine will do a better and safer job if used as intended. **DO NOT** use inappropriate attachments in an attempt to exceed the machine's rated capacity.
9. **Use the right tool for the job. DO NOT** attempt to force a small tool or attachment to do the work of a large industrial tool. **DO NOT** use a tool for a purpose for which it was not intended.
10. **Dress appropriately. DO NOT** wear loose fitting clothing or jewelry as they can be caught in moving machine parts. Protective clothing and steel toe shoes are recommended when using machinery. Wear a restrictive hair covering to contain long hair.
11. **Use eye protection.** Always wear ISO approved protective eye wear when operating machinery. Wear a full-face shield if you are producing metal filings. Eye wear shall be impact resistant, protective safety glasses with side shields which comply with ANSI Z87.1 specification. Use of eye wear which does not comply with ANSI Z87.1 specification could result in severe injury from breakage of eye protection.
12. **Do not overreach.** Maintain proper footing and balance at all times. **DO NOT** reach over or across a running machine.
13. **Stay alert.** Watch what you are doing and use common sense. **DO NOT** operate any tool or machine when you are tired.
14. **Check for damaged parts.** Before using any tool or machine, carefully check any part that appears damaged. Check for alignment and binding of moving parts that may affect proper machine operation.
15. **Observe work area conditions. DO NOT** use machines or power tools in damp or wet locations. Do not expose to rain. Keep work area well lighted. **DO NOT** use electrically powered tools in the presence of flammable gases or liquids.
16. **Blade adjustments and maintenance.** Always keep blades sharp and properly adjusted for optimum performance.
17. **Keep children away.** Children must never be allowed in the work area. **DO NOT** let them handle machines, tools, or extension cords.
18. Keep visitors a safe distance from the work area.
19. **Store idle equipment.** When not in use, tools must be stored in a dry location to inhibit rust. Always lock up tools and keep them out of reach of children.
20. **DO NOT operate machine if under the influence of alcohol or drugs.** Read warning labels on prescriptions. If there is any doubt, **DO NOT** operate the machine.
21. **Turn off** power before checking, cleaning, or replacing any parts.
22. Be sure **all** equipment is properly installed and grounded according to national, state, and local codes.



23. Keep **all** cords dry, free from grease and oil, and protected from sparks and hot metal.
24. Inspect power and control cables periodically. Replace if damaged or bare wires are exposed. **Bare wiring can kill!** **DO NOT** touch live electrical components or parts.
25. **DO NOT** bypass or defeat any safety interlock systems.



WARNING: This product can expose you to chemicals including titanium dioxide which is known to the State of California to cause cancer, and lead which is known to the State of California to cause cancer and birth defects or other reproductive harm.

For more information go to <http://www.p65warnings.ca.gov>.



WARNING: Some dust, fumes and gases created by power sanding, sawing, grinding, drilling, welding, and other construction activities contain chemicals known to the State of California to cause cancer and birth defects or other reproductive harm. Some examples of these chemicals are:

- lead from lead-based paint.
- crystalline silica from bricks, cement, and other masonry products.
- arsenic and chromium from chemically treated lumber.

Your risk of exposure varies, depending on how often you do this type of work. To reduce your exposure to these chemicals, work in a well-ventilated area and work with approved safety equipment, such as dust masks that are specifically designed to filter out microscopic particles.

For more information go to <http://www.p65warnings.ca.gov/> and <http://www.p65warnings.ca.gov/wood>.



TECHNICAL SPECIFICATIONS

Capacity 90° Round	7" (180mm)
Rectangular	7" x 10.23" (180 x 260mm)
Capacity 45° Round	4" (100mm)
Rectangular	3.75" x 4" (95 x 100mm)
Return	Manual
Miter Adjustment	Swivel Head
Miter Angle	0 - 45°
Vise Table Height	30.625" (777mm)
Blade Size (H x T x L)	.75" x .035" x 92.91" (19 x .9 x 2360mm)
Blade Speed	3@ 145, 200, 245fpm (48, 66, 80mpm)
Bow Decent Control	Closed Hydraulic with needle valve
Drive	Gear
Table Height	23" (584mm)
Power	120V, 1ph, 60hz
Motor	1hp (.75kw) 120V, 1ph, 60hz, 14A
Net Weight	397lbs. (181kg)
Shipping Weight	462lbs. (210kg)
Shipping Dimensions	50" x 22" x 44" (1270 x 559 x 1118mm)

TECHNICAL SUPPORT

Our technical support department can be reached at 920.684.4990 and asking for the support desk for purchased machines. Tech Support handles questions on machine setup, schematics, warranty issues, and individual parts needs: (other than die sets and blades).

For specific application needs or future machine purchases contact the Sales Department at: Baileigh-Sales@jpwindustries.com, Phone: 920.684.4990, or Fax: 920.684.3944.



Note: *The photos and illustrations used in this manual are representative only and may not depict the actual color, labeling or accessories and may be intended to illustrate technique only.*



Note: *The specifications and dimensions presented here are subject to change without prior notice due to improvements of our products.*



UNPACKING AND CHECKING CONTENTS

Your Baileigh Industrial machine is shipped complete. Separate all parts from the packing material and check each item carefully. Make certain all items are accounted for before discarding any packing material.

⚠ WARNING: SUFFOCATION HAZARD! Immediately discard any plastic bags and packing materials to eliminate choking and suffocation hazards to children and animals.
If any parts are missing, **DO NOT** place the machine into service until the missing parts are obtained and installed correctly.

Cleaning

⚠ WARNING: DO NOT USE gasoline or other petroleum products to clean the machine. They have low flash points and can explode or cause fire.

⚠ CAUTION: When using cleaning solvents work in a well-ventilated area. Many cleaning solvents are toxic if inhaled.

Your machine may be shipped with a rustproof waxy coating and/or grease on the exposed unpainted metal surfaces. Fully and completely remove this protective coating using a degreaser or solvent cleaner. Moving items will need to be moved along their travel path to allow for cleaning the entire surface. For a more thorough cleaning, some parts will occasionally have to be removed. **DO NOT USE** acetone or brake cleaner as they may damage painted surfaces.

Follow manufacturer's label instructions when using any type of cleaning product. After cleaning, wipe unpainted metal surfaces with a light coating of quality oil or grease for protection.



Important: This waxy coating is **NOT** a lubricant and will cause the machine to stick and lose performance as the coating continues to dry.





Shipping Container Contents

- 1 Saw
- 1 Base-left end
- 1 Base-right end
- 2 Base-sides
- 1 Hardware bag (includes (4) ea. hex bolt and flat washers.)





- 1 Stop bracket
- 1 Stop rod
- 1 Work stop
- 1 Saw bow guard w/hardware
- 1 Drain screen
- 1 Lift handle w/hardware
- 1 Support leg w/hardware
- 2 Wheels w/bearings
- 1 Axle w/ (2) hitch pins & (2) flat washers





TRANSPORTING AND LIFTING

NOTICE: *Lifting and carrying operations should be carried out by skilled workers, such as a truck operator, crane operator, etc. If a crane is used to lift the machine, attach the lifting chain carefully, making sure the machine is well balanced.*

Follow these guidelines when lifting with truck or trolley:

- The lift truck must be able to lift at least 1.5 – 2 times the machines gross weight.
- Make sure the machine is balanced. While transporting, avoid rough or jerky motion, and maintain a safe clearance zone around the transport area.
- Use a forklift with sufficient lifting capacity and forks that are long enough to reach the complete width of the machine.
- Remove the securing bolts that attach the machine to the pallet.
- Approaching the machine from the side, lift the machine on the frame taking care that there are no cables or pipes in the area of the forks.
- Move the machine to the required position and lower gently to the floor.
- Level the machine so that all the supporting feet are taking the weight of the machine and no rocking is taking place.

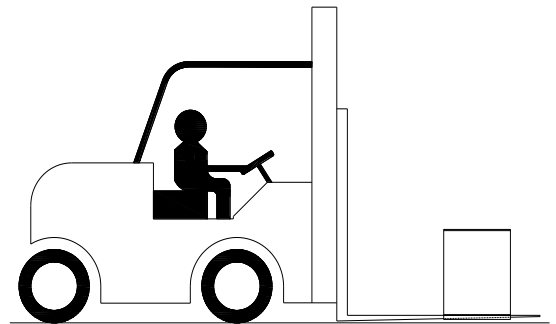

INSTALLATION

IMPORTANT:

Consider the following when looking for a suitable location to place the machine:

- Overall weight of the machine.
- Weight of material being processed.
- Sizes of material to be processed through the machine.
- Space needed for auxiliary stands, worktables, or other machinery.
- Clearance from walls and other obstacles.
- Maintain an adequate working area around the machine for safety.
- Have the work area well illuminated with proper lighting.
- Keep the floor free of oil and make sure it is not slippery.



- Remove scrap and waste materials regularly, and make sure the work area is free from obstructing objects.
- If long lengths of material are to be fed into the machine, make sure that they will not extend into any aisles.
- **LEVELING:** The machine should be sited on a level, concrete floor. Provisions for securing it should be in position prior to placing the machine. The accuracy of any machine depends on the precise placement of it to the mounting surface.
- **FLOOR:** This machine distributes a large amount of weight over a small area. Make certain that the floor is capable of supporting the weight of the machine, work stock, and the operator. The floor should also be a level surface. If the unit wobbles or rocks once in place, be sure to eliminate by using shims.
- **WORKING CLEARANCES:** Take into consideration the size of the material to be processed. Make sure that you allow enough space for you to operate the machine freely.
- **POWER SUPPLY PLACEMENT:** The power supply should be located close enough to the machine so that the power cord is not in an area where it would cause a tripping hazard. Be sure to observe all electrical codes if installing new circuits and/or outlets.



OVERALL DIMENSIONS

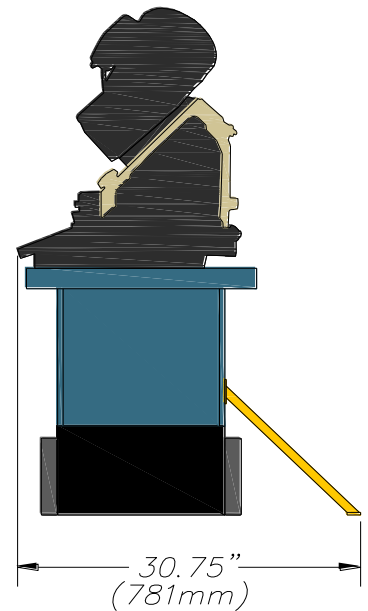
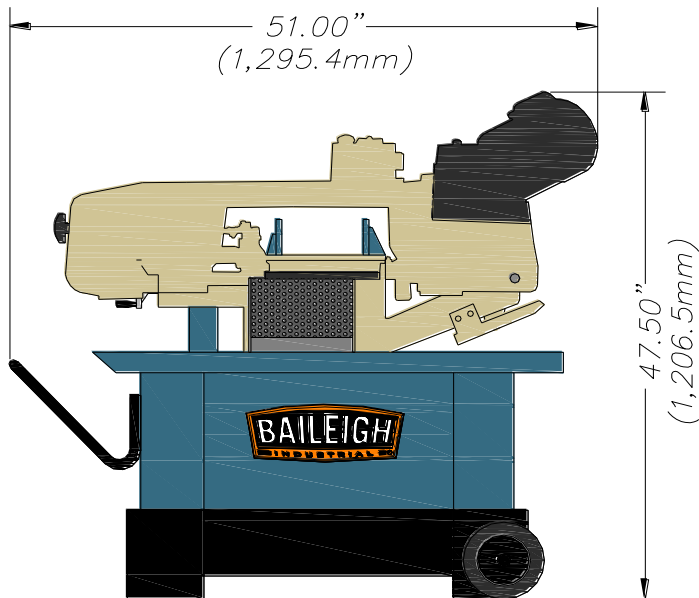
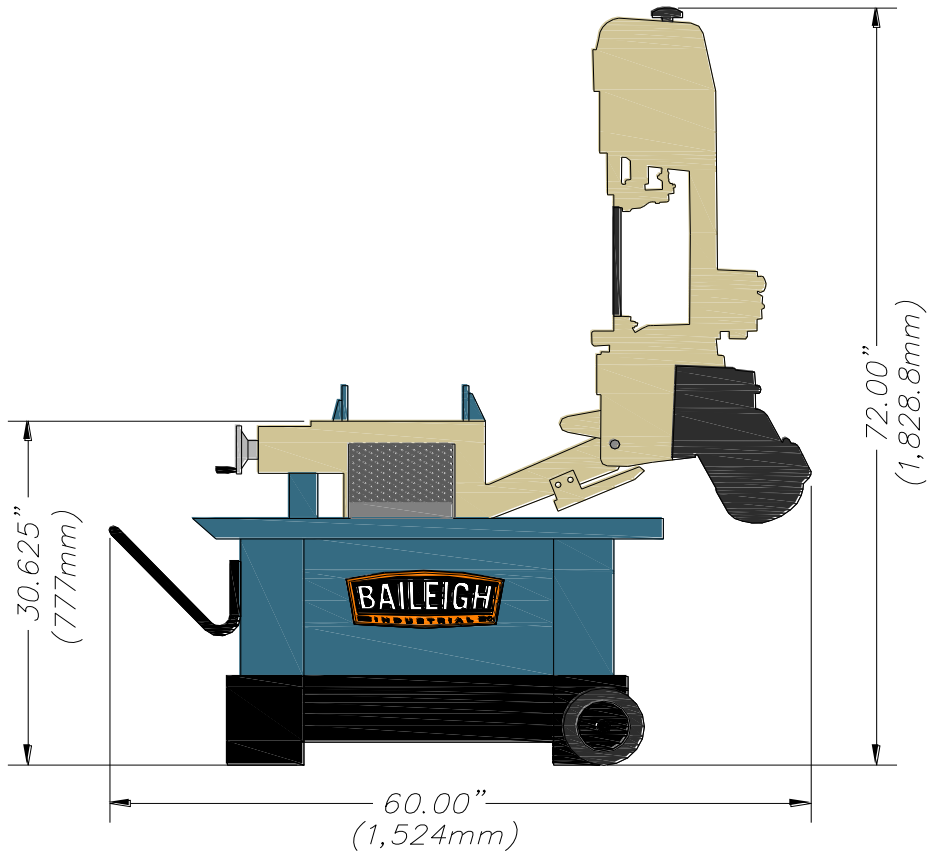



GETTING TO KNOW YOUR MACHINE



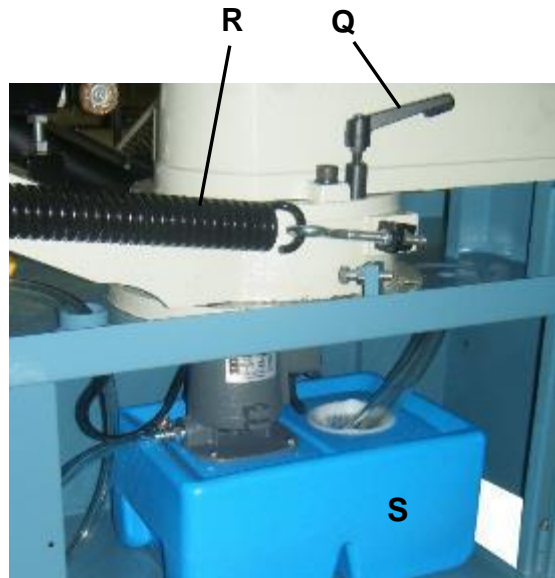
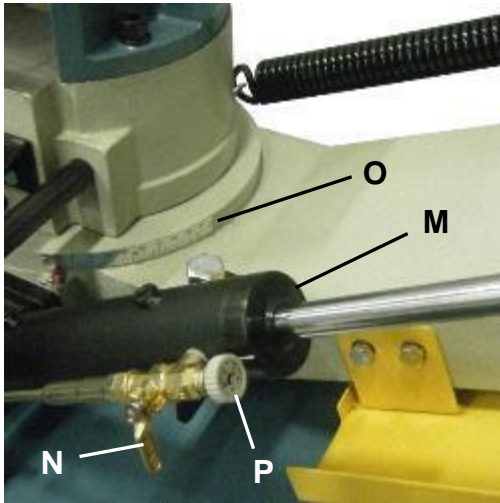

Item	Description	Function
A	Front and rear jaw	For clamping material.
B	Blade tension knob	Used to increase or decrease blade tension
C	Blade tension side plate	Holds adjustable head pulley
D	Blade adjustment assembly	Adjusts front end of blade
E	Blade adjustment assembly	Adjusts rear end of blade
F	On - Off pushbuttons	Used to start and stop saw motor
G	"E" - Stop pushbutton	Press to stop saw motor in an emergency
H	Vise hand wheel	Turning hand wheel opens and closes vise
I	Motor/gearbox	Drives the saw blade
J	Discharge Tray	Directs the cut piece part from the saw
K	Speed knob	3 position gear selector to change blade speeds
L	Material stop bar	For setting the length of cut
M	Hydraulic drop cylinder	Handles up/down movement of the blade head
N	Ball valve	Starts and stops the blade descent
O	Mitering Scale	Indicates angle that material is to be cut at.
P	Needle valve	Turn (cw) to slow descent, (ccw) to accelerate
Q	Miter Lock Lever	Turn counterclockwise (ccw) to unlock the saw head to set the cut angle
R	Tension spring	Assists with raising and lowering saw head
S	Coolant System	Circulates coolant to lubricate and cool blade



ASSEMBLY AND SET UP

⚠ WARNING: For your own safety, DO NOT connect the machine to the power source until the machine is completely assembled and you read and understand the entire instruction manual.

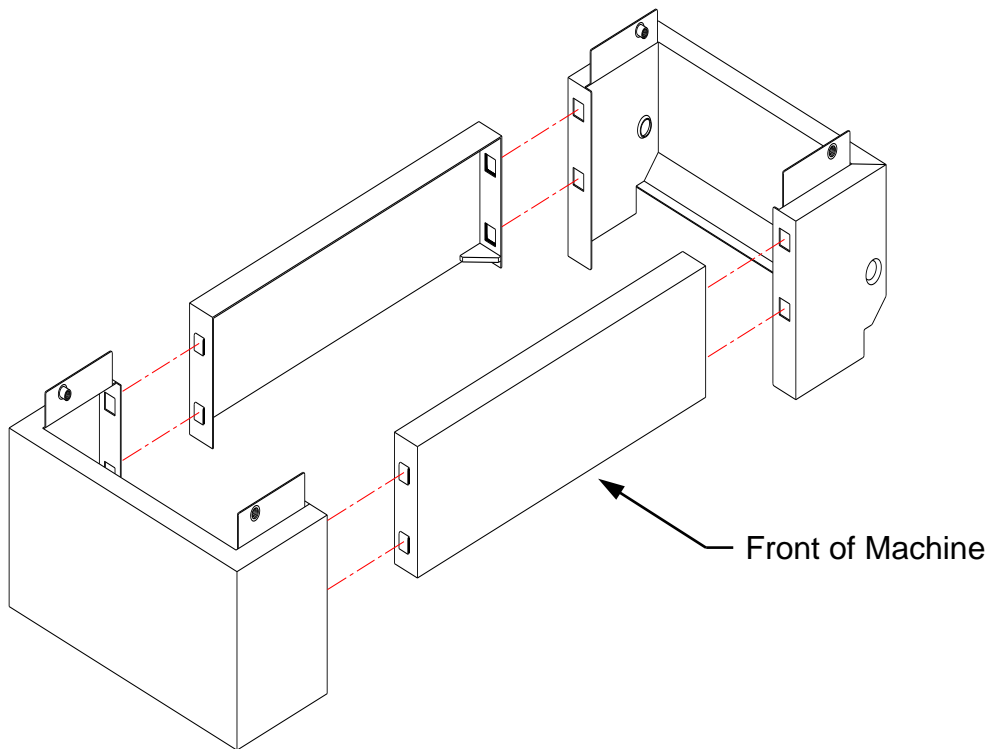

1. Insert the tabs on the side panels into the square openings of the end panels.
2. Push down on the side panels until they lock.
3. Insert the axle into the holes on the right end panel as shown.
4. Push each wheel onto the axle, slip on a flat washer, and secure each with a cotter pin.

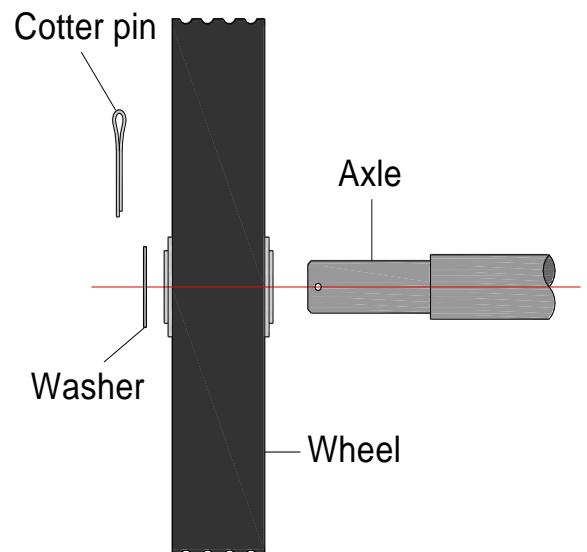

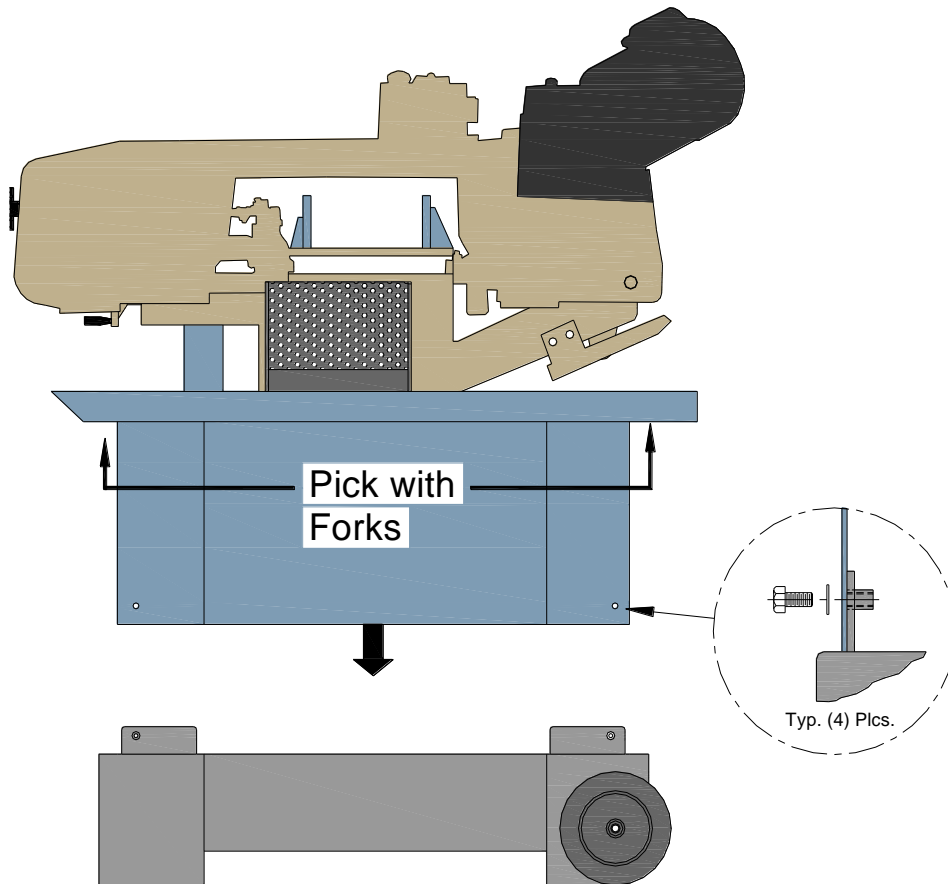

5. Unbolt and remove the (4) angle brackets that hold the saw to the pallet base.
6. Carefully pick up the saw and place onto the assembled wheelbase.
7. Secure with the (4) bolts and flat washers provided.
8. Screw the threaded stop rod into the vise base and assemble the material stop onto the stop rod as shown. The material stop can be adjusted to suit a variety of material configurations.





9. Remove the shipping strap that holds the saw bow down. Save the strap and use whenever transporting the saw.



10. Attach the handle to the saw with the hex bolts, flat washers, lock washers, and hex nuts provided. For the correct orientation. Use the access door on the rear of the machine when attaching the nuts.



Attaching the Support Bar

The support bar helps to prevent the saw from tipping over when the bow is in the vertical sawing position.

Attach the bar to the back of the saw, just left of the coolant access doorknob. Use the (2) hex bolts and lock washers provided.

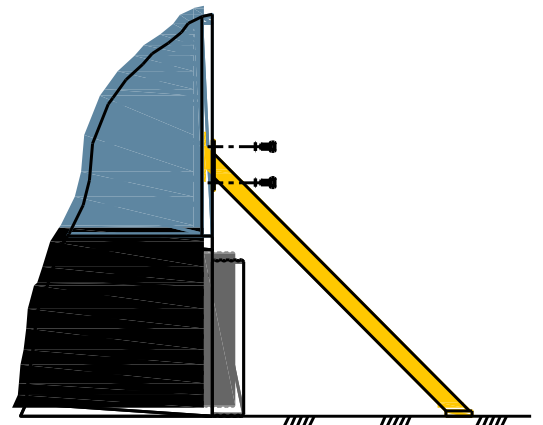

⚠ CAUTION: AVOID TIP OVER! The Support Bar must be installed prior to using the saw in the vertical position.



Attaching the Saw Bow Cover Guard

Using the (2) hex bolts, lock washers, and flat washers provided, attach the bow cover guard.



Coolant Tank Preparation

Use a 20:1 (water to coolant) solution to increase cutting efficiency and prolong blade life.

1. Disconnect machine from the power source.
2. Remove the coolant return hose from the drain pan fitting and the strainer basket.
3. Slide the tank out from the lower compartment.
4. Remove the strainer basket and fill the tank to 80% capacity with coolant.
5. Replace the strainer basket and return the tank assembly back into the base.
6. Place the drain hose into the basket and connect to the drain fitting.
7. Assemble the bolt to the drain screen as shown and set over the drain hole.

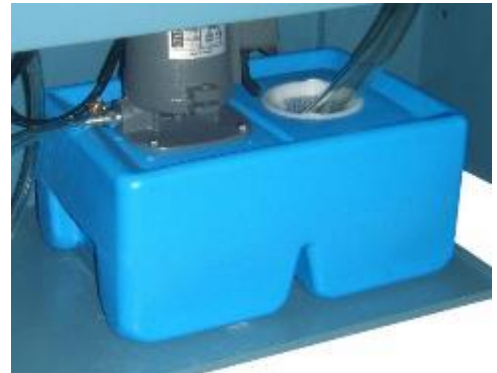



ELECTRICAL

 **CAUTION:** HAVE ELECTRICAL UTILITIES CONNECTED TO MACHINE BY A CERTIFIED ELECTRICIAN!
Check if the available power supply is the same as listed on the machine nameplate.

 **WARNING:** Make sure the grounding wire (green) is properly connected to avoid electric shock. DO NOT switch the position of the green grounding wire if any electrical plug wires are switched during hookup.

Power Specifications

Your machine is wired for 220 volts, 60hz alternating current. Before connecting the machine to the power source, make sure the power source is OFF.

Before switching on the power, you must check the voltage and frequency of the power to see if they meet with the requirement, the allowed range for the voltage is $\pm 5\%$, and for the frequency is $\pm 1\%$.

Considerations

- Observe local electrical codes when connecting the machine.
- The circuit should be protected with a time delay fuse or circuit breaker with an amperage rating slightly higher than the full load current of machine.
- A separate electrical circuit should be used for your machines. Before connecting the motor to the power line, make sure the switch is in the "OFF" position and be sure that the electric current is of the same characteristics as indicated on the machine.
- All line connections should make good contact. Running on low voltage will damage the motor.
- In the event of a malfunction or breakdown, grounding provides a path of least resistance for electric current to reduce the risk of electric shock. This machine is equipped with an electric cord having an equipment-grounding conductor and a grounding plug. The plug must be plugged into a matching outlet that is properly installed and grounded in accordance with all local codes and ordinances.

 **WARNING:** In all cases, make certain the receptacle in question is properly grounded. If you are not sure, have a qualified electrician check the receptacle.



- Improper connection of the equipment-grounding conductor can result in risk of electric shock. The conductor with insulation having an outer surface that is green with or without yellow stripes is the equipment-grounding conductor. If repair or replacement of the electric cord or plug is necessary, do not connect the equipment-grounding conductor to a live terminal.
- Check with qualified electrician or service personnel if the grounding instructions are not completely understood, or if in doubt as to whether the machine is properly grounded.
- Repair or replace damaged or worn cord immediately.

Extension Cord Safety

Extension cord should be in good condition and meet the minimum wire gauge requirements listed below:

AMP RATING	LENGTH		
	25ft	50ft	100ft
1-12	16	16	14
13-16	14	12	12
17-20	12	12	10
21-30	10	10	No
WIRE GAUGE			

An undersized cord decreases line voltage, causing loss of power and overheating. All cords should use a ground wire and plug pin. Replace any damaged cords immediately.

Power cord connection:

1. Turn the main disconnect switch on the control panel to the OFF position.
2. Unwrap the power cord and route the cord away from the machine toward the power supply.
 - a. Route the power cord so that it will NOT become entangled in the machine in any way.
 - b. Route the cord to the power supply in a way that does NOT create a trip hazard.
3. Connect the power cord to the power supply and check that the power cord has not been damaged during installation.
4. When the machine is clear of any obstruction. The main power switch may be turn ON to test the operation. Turn the switch OFF when the machine is not in operation.



BEFORE EACH USE

- For dusty operations, wear a face shield along with safety goggles.
- It is important to choose the right blade for the material and the type of cutting you plan to do. This saw is equipped with a bi-metallic blade which can be used to cut stainless steel, steel, iron, brass, aluminum, wood, plastic.
- Make sure the direction of rotation arrow on the blade matches the direction arrow on the saw. The blade teeth should always point downward at the front of the saw.
- Make sure the blade is sharp, undamaged and properly aligned. With the saw unplugged, push the power-head all the way down. Rotate the blade by hand checking for clearance. If the blade hits anything, make the adjustments shown in the Maintaining Maximum Cutting Capacity section.
- Never cut freehand.
- Make sure the cut-off piece can move sideways after it is cut off. Otherwise, it could get wedged against the blade and thrown violently.
- Never turn the saw "ON" before clearing everything except the work piece beneath the blade.
- Never put lubricants on the blade while it is spinning.

Whenever Saw is Running

- Never confine the piece being cut out.
- Never hold it, clamp it, touch it, or use length stops against it. It must be free to move sideways. If confined, it could get wedged against the blade and thrown violently.
- Avoid awkward hand positions where a sudden slip could cause a hand to move into the blade.
- Let the blade reach full speed before cutting.
- Feed the saw into the work piece only fast enough to let the blade cut without bogging down or binding.
- Before freeing jammed material, turn the switch off and unplug the saw. Wait for all moving parts to stop.
- After finishing a cut, keep holding the saw bow down, release the switch, and wait for all moving parts to stop before moving your hands.



Breaking in a Band Saw Blade

Sharp cutting edges with extremely small edge radii are required for high cutting capacity. To achieve the optimal tool life we recommend breaking-in the blade accordingly. The correct cutting speed is determined by the material being cut and its dimensions. It is very important that the new blade is first used with only 50% of the determined feed rate. This will avoid micro-breakages of the blade because of too large chip thicknesses. New band saw blades may tend toward vibrations and vibration sounds. In this case a slight reduction of the cutting speed is helpful. With small workpiece dimensions approximately 300cm² of the material should be cut for breaking-in. If large work piece dimensions are to be cut we recommend a breaking-in period of about 15 minutes. After breaking-in you may slowly increase the feed rate up to the determined value.

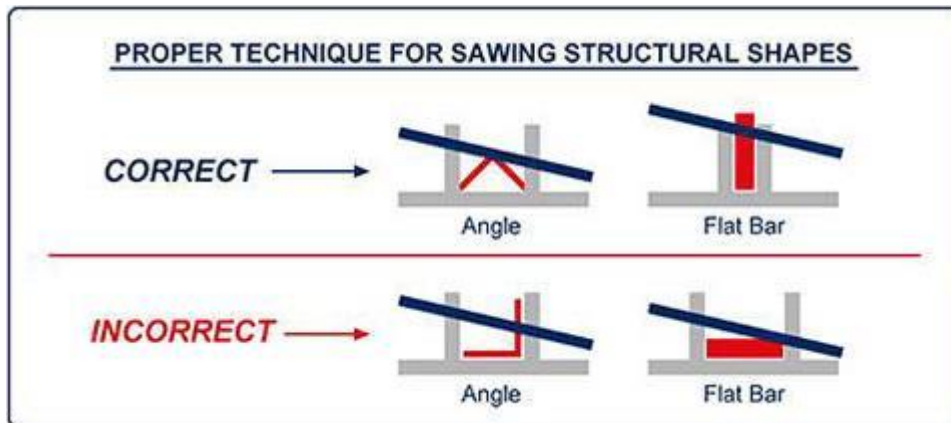

Metal Chip Indicators

Chips are the best indicator of correct material feed force. Monitor chip information and adjust feed accordingly.

- Thin or Powdered Chips – increase feed rate or reduce saw speed
- Burned Chips – reduce feed rate and / or saw speed
- Curly Silvery and Warm Chips – optimum feed rate and saw speed

Baileigh Industrial offers a wide selection of tooth styles for various cutting applications. Please phone Baileigh Industrial at (920.684.4990) or fax to (920.684.3944) to have one of our technicians assist you in selecting the proper band saw blade for your cutting applications.



Blade Terminology

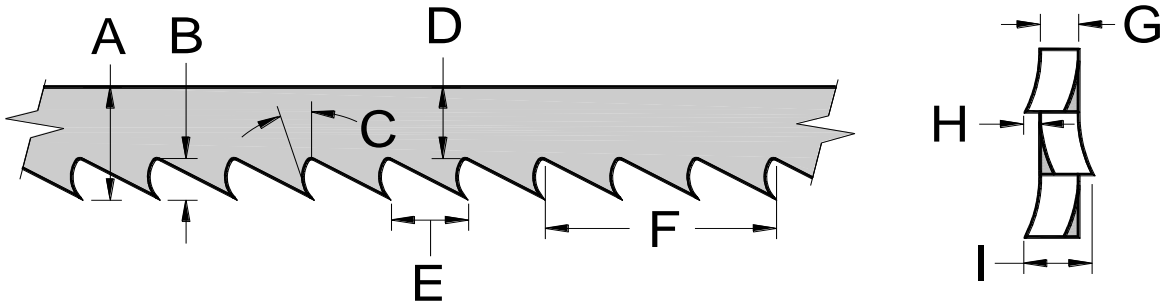

A	BLADE WIDTH	The widest part of the blade measured from the back edge of the blade to the tip of the tooth.
B	GULLET DEPTH	The distance from the tooth tip to the bottom of the curved area.
C	TOOTH RAKE	The angle of the tooth face from a line perpendicular to the length of the blade.
D	BLADE BACK	The distance between the back edge of the blade and the bottom of the gullet.
E	TOOTH PITCH	The distance between tooth tips.
F	TPI	The number of teeth per inch when measured from gullet to gullet.
G	GAUGE	The thickness of the blade.
H	TOOTH SET	The distance a tooth is bent from the blade.
I	KERF	The width of material that is removed by the blade when cutting.

Width of Blade

The blade width determines the largest and the smallest curve that can be cut. Usually the wider a blade is, the more accurate and straighter it will cut.

Length of Blade

The length of the band saw blade can be measured with a tape measure at it's circumference or by the formula below:

$$\text{Blade Length} = (2 \times A) + (3.14 \times B)$$

A = the distance in inches between the band saw pulley centers (when the upper pulley is midway in its adjustment range).

B = the band saw pulley diameter.



Blade structure

Bi-metal blades are the most commonly used. They consist of a silicon-steel blade backing by a laser welded high speed steel (HSS) cutting edge. The type of stocks are classified in M2, M42, M51 and differ from each other because of their major hardness due to the increasing percentage of Cobalt (C_c) and molybdenum (Mo) contained in the metal alloy.

Blade type

They differ essentially in their constructive characteristics, such as:

- Shape and cutting angle of tooth
- Pitch
- Set

Shape and angle of tooth

REGULAR TOOTH: 0° rake and constant pitch.



Most common form for transversal or inclined cutting of solid small and average cross-sections or pipes, in laminated mild steel and gray iron or general metal.

POSITIVE RAKE TOOTH: 9° - 10° positive rake and constant pitch.



Particular use for crosswise or inclined cuts in solid sections or large pipes, but above all harder materials (highly alloyed and stainless steels, special bronze and forge pig iron).

COMBO TOOTH: pitch varies between teeth and consequently varying teeth size and varying gullet depths. Pitch varies between teeth, which ensures a smoother, quieter cut and longer blade life owing to the lack of vibration.

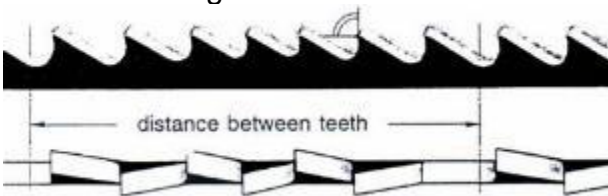

Another advantage offered in the use of this type of blade in the fact that with an only blade it is possible to cut a wide range of different materials in size and type.



COMBO TOOTH: 9° - 10° positive rake.

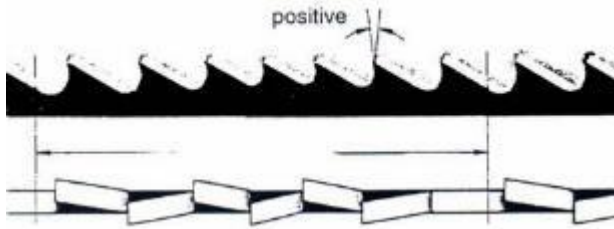

This type of blade is the most suitable for the cutting of section bars and large and thick pipes as well as for the cutting of solid bars at maximum machine capacity. Available pitches: 3-4/4-6.

SETS

Saw teeth bent out of the plane of the saw body, resulting in a wide cut in the workpiece.

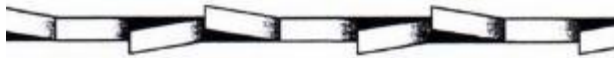

REGULAR OR RAKER SET: Cutting teeth right and left, alternated by a straight tooth.

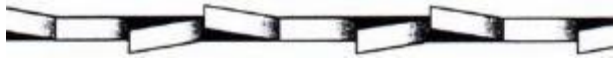

Of general use for materials with dimensions superior to 5 mm. Used for the cutting of steel, castings and hard nonferrous materials.

WAVY SET: Set in smooth waves.



This set is associated with very fine teeth and it is mainly used for the cutting of pipes and thin section bars (from 1 to 3 mm).

ALTERNATE SET (IN GROUPS): Groups of cutting teeth right and left, alternated by a straight tooth.



This set is associated with very fine teeth and it is used for extremely thin materials (less than 1mm).

ALTERNATE SET (INDIVIDUAL TEETH): Cutting teeth right and left.



This set is used for the cutting of nonferrous soft materials, plastics and wood.



BLADE CARE

The bandsaw blade is subjected to a tremendous amount of strain. Make sure to always use the appropriate feed rate for the type material you are cutting.

Be sure to select a blade of the proper width, style, and pitch that will produce the best cut in your material. Choosing the wrong blade can produce excess heat that can adversely affect the life of the blade.

A clean blade performs much better than one that is dirty. Blades that are gummed up and dirty offer more resistance when cutting through the material. This in turn creates unnecessary heat in the blade.

CHOOSING A SAW BLADE

A general purpose blade is furnished with this band saw.

To achieve a quality, economical, and efficient saw cut, the following points must be taken into consideration:

- Type of material being cut (ferrous or non ferrous)
- Material hardness and physical dimensions
- Blade descent rate
- Longitudinal speed of blade
- Blade tooth profile

Choose a tooth pitch that is suitable for the workpiece. Thin walled profiles, including tubes and pipes require close toothing. At least 3-6 teeth should be in contact with the material while cutting. Large solid or transverse sections require widely spaced toothing to allow for greater volume of chips and better tooth penetration. Soft materials such as plastics, light alloys, mild bronze, Teflon, etc. require widely spaced toothing to avoid clogging.



S	Outer Diameter of the Tube (inch) / Tooth pitch																
	0.787	1.574	2.362	3.15	4	4.724	6	7.873	11.811	15.75	19.685	23.621	27.5	31.5	35.5	39.5	59
0.079	14	14	14	14	14	14	10-14tpi	10-14tpi	8-12tpi	8-12tpi	8-12tpi	6-10tpi	5-8tpi	5-8tpi	5-8tpi	5-8tpi	5-8tpi
0.118	14	14	10-14tpi	10-14tpi	10-14tpi	10-14tpi	8-12tpi	8-12tpi	6-10tpi	6-10tpi	5-8tpi	5-8tpi	5-8tpi	4-6tpi	4-6tpi	4-6tpi	4-6tpi
0.157	14	14	10-14tpi	10-14tpi	10-14tpi	10-14tpi	8-12tpi	8-12tpi	6-10tpi	6-10tpi	5-8tpi	4-6tpi	4-6tpi	4-6tpi	4-6tpi	4-6tpi	4-6tpi
0.197	14	10-14tpi	10-14tpi	10-14tpi	10-14tpi	10-14tpi	8-12tpi	8-12tpi	6-10tpi	6-10tpi	5-8tpi	4-6tpi	4-6tpi	4-6tpi	3-4tpi	3-4tpi	3-4tpi
0.236	14	10-14tpi	10-14tpi	8-12tpi	8-12tpi	8-12tpi	8-12tpi	8-12tpi	6-10tpi	6-10tpi	5-8tpi	4-6tpi	4-6tpi	3-4tpi	3-4tpi	3-4tpi	3-4tpi
0.315	14	10-14tpi	8-12tpi	8-12tpi	8-12tpi	8-12tpi	8-12tpi	8-12tpi	6-10tpi	6-10tpi	5-8tpi	4-6tpi	4-6tpi	3-4tpi	3-4tpi	3-4tpi	2-3tpi
0.394		8-12tpi	6-10tpi	6-10tpi	6-10tpi	5-8tpi	5-8tpi	4-6tpi	4-6tpi	4-6tpi	4-6tpi	3-4tpi	3-4tpi	3-4tpi	2-3tpi	2-3tpi	2-3tpi
0.472		8-12tpi	6-10tpi	6-10tpi	5-8tpi	5-8tpi	4-6tpi	4-6tpi	4-6tpi	3-4tpi	3-4tpi	3-4tpi	3-4tpi	2-3tpi	2-3tpi	2-3tpi	2-3tpi
0.591		8-12tpi	6-10tpi	5-8tpi	5-8tpi	4-6tpi	4-6tpi	4-6tpi	3-4tpi	3-4tpi	2-3tpi	2-3tpi	2-3tpi	2-3tpi	2-3tpi	2-3tpi	2-3tpi
0.787			6-10tpi	5-8tpi	4-6tpi	4-6tpi	4-6tpi	3-4tpi	3-4tpi	3-4tpi	2-3tpi	2-3tpi	2-3tpi	2-3tpi	2-3tpi	2-3tpi	2-3tpi
1.181				4-6tpi	4-6tpi	3-4tpi	3-4tpi	3-4tpi	2-3tpi	2-3tpi	2-3tpi	2-3tpi	2-3tpi	2-3tpi	1-4-2tpi	1-4-2tpi	1-4-2tpi
2						3-4tpi	3-4tpi	2-3tpi	2-3tpi	2-3tpi	2-3tpi	2-3tpi	2-3tpi	2-3tpi	1-4-2tpi	1-4-2tpi	1-4-2tpi
3								2-3tpi	2-3tpi	2-3tpi	2-3tpi	2-3tpi	1-4-2tpi	1-4-2tpi	1-4-2tpi	1-4-2tpi	1-4-2tpi
4								2-3tpi	2-3tpi	2-3tpi	2-3tpi	1-4-2tpi	1-4-2tpi	1-4-2tpi	1-4-2tpi	1-4-2tpi	1-4-2tpi
6												1-4-2tpi	1-4-2tpi	1-4-2tpi	1-4-2tpi	1-4-2tpi	1-4-2tpi
7.873												1-4-2tpi	1-4-2tpi	1-4-2tpi	1-4-2tpi	1-4-2tpi	1-4-2tpi
9.842												1-4-2tpi	1-4-2tpi	1-4-2tpi	1-4-2tpi	1-4-2tpi	1-4-2tpi
11.81												1-4-2tpi	1-4-2tpi	1-4-2tpi	1-4-2tpi	1-4-2tpi	1-4-2tpi
13.778																	
15.747																	
17.716																	
19.685																	

S= Wall Thickness
 If you have to cut two or more tubes lying side by side please use this table in consideration of the double wall thickness (s).



BLADE BREAKAGE

In some cases blade breakage is unavoidable due to the stresses that are imparted on the blade. Avoidable breakage is often the result of poor care, or poor operator judgment when it comes to adjusting or mounting the blade or blade guides.

Listed below are some of the more common reasons for blade breakage.

- Top blade guide assembly is set too high above the piece part.
- The blade is tensioned incorrectly.
- Piece part is fed into the blade too quickly.
- Blade teeth are dull or broken.
- Blade is not properly aligned with the guides.
- Forcing a large width blade to cut a small radius.
- Using a blade with an improperly finished weld joint.
- Allowing the blade to run when not in use. (**NEVER** leave an unattended blade running.)

MATERIAL SELECTION

 **CAUTION:** It must be determined by the customer that materials being processed through the machine are **NOT** potentially hazardous to operator or personnel working nearby.

When selecting materials keep these instructions in mind:

- Material must be clean and dry. (without oil)
- Material should have a smooth surface so it processes easily.
- Dimensional properties of material must be consistent and not exceed the machine capacity values.
- Chemical structure of material must be consistent.
- Buy certificated steel from the same vendor when possible.



MACHINE ADJUSTMENTS

⚠ WARNING: Make sure the electrical disconnect is OFF before working on the machine.
Always follow proper safety precautions when working on or around any machinery.

Blade Guide Adjustment

1. Disconnect saw from the power source.
2. Loosen knobs “D” and “E”.
3. Slide the blade guide assemblies as close as possible to the work piece without interfering with the cut or vise.
4. Tighten knobs “D” and “E”.
5. Reconnect the saw to the power source.

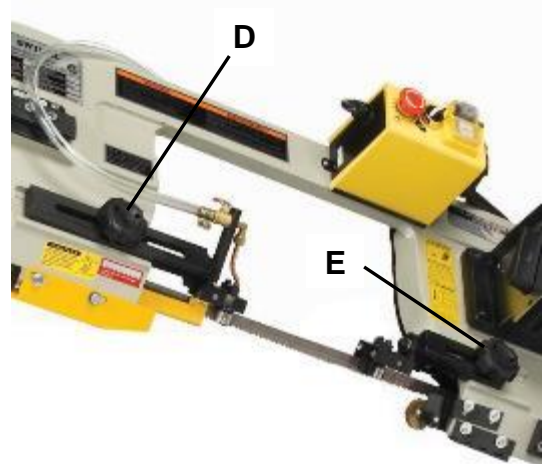

Swivel Saw Head

⚠ WARNING: Do not make any adjustments or load / unload material from the vise while the saw is running. Failure to comply may cause serious injury.

Angles can be cut from 0 to 45° left with the BS-712MS band saw.

1. Unlock the rotating saw bow by turning the clamp handle counterclockwise (ccw).
2. Rotate the saw bow to the desired angle as shown on the red angle indicator.
3. Lock the bow by turning the clamp handle clockwise (cw).

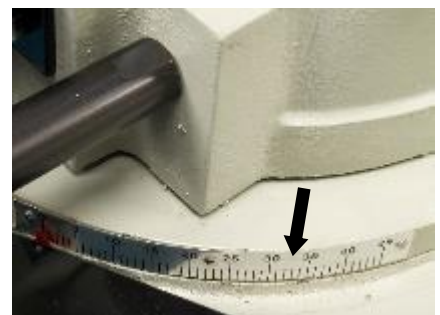

⚠ CAUTION: Make sure saw bow is in a down or horizontal position when moving or mitering, to avoid tipping the machine.



- The two adjusting bolts shown in (fig. 23) are used to stop the saw bow at both 0° and 45° as indicated on the scale.
- Make sure the jam nuts are tight.

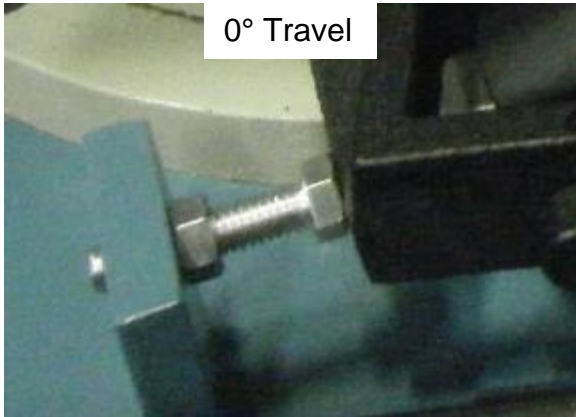

Adjusting Automatic Shut-off

The saw should stop after the cut has been made. This adjustment is completed by adjusting both the down travel bolt (U) and limit switch activation bolt (T).

- First, adjust the stop bolt for the down travel. Adjust the bolt (U) to stop the downward travel of the saw bow to a position that just cuts through the material but does not cut into the vise table.
- When adjusted, hold the bolt in position and tighten the nut to the bracket to hold the bolt in place.
- If the saw completes the cut and continues to run, adjust the stop bolt (T) out.
- If the saw shuts off before the cut is complete, adjust the stop bolt (T) in.
- When adjusted, hold the bolt in position and tighten the nut to the bracket to hold the bolt in place.
- Balance the adjustment between the two stop bolts so the motor cuts off as soon as the cut has been completed.

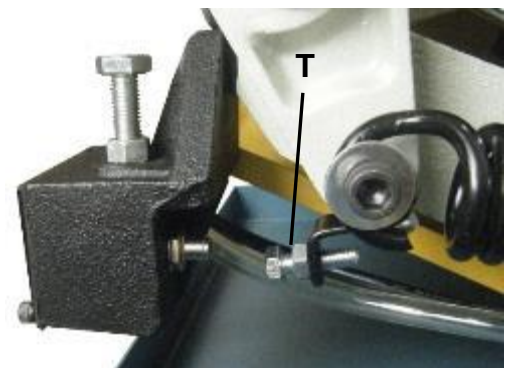
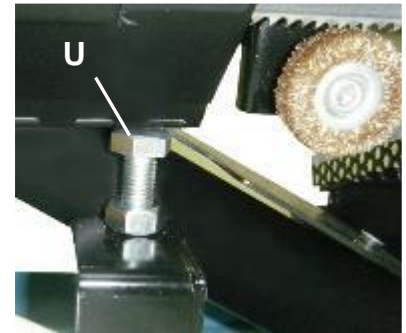

Note: The limits switch is a normally closed switch. It stops the motor from running when pushed in. It allows the motor to run when released. If the switch is dirty or sticky from coolant or metal chips it may stick open and prevent the motor from running. Clean as needed.



Adjusting Blade Tension

Blade tension is important to the proper operation of the saw. The saw should be set in the “High Tension” range (about 2,300 psi) when you are finished with the blade tension setup.

To set the blade tension without the use of a blade tension gauge:

1. Install blade onto the pulleys and insert between the bearings on the blade guides.
2. Loosen the two hex bolts.
3. Tension the blade slightly by turning the knob clockwise (cw), to remove any sag of the blade between the bearing wheels.
4. Now turn the knob an additional 1-3/4 - 2 turns clockwise (cw). This equals approximately 2,300 lbs. of blade tension. Use the Dynametric Tension Band setting as a reference.
5. Once the white indicator line is centered in the blue section, re-tighten the two hex bolts.

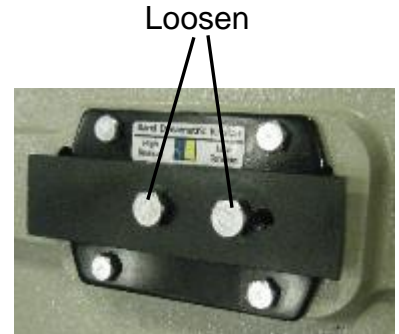

NOTICE: *Lifting and* Do not overtighten the blade. This may cause the blade to stretch and warp.

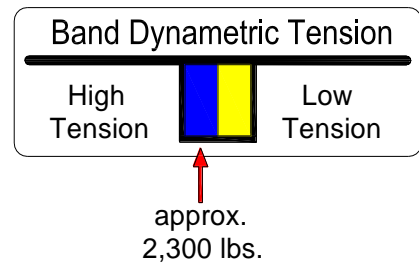

Adjusting Bow Weight

The extension spring which helps control the downward movement of the saw bow was preset at the factory. No additional adjustment to the spring should be necessary.





Changing the Blade

⚠ CAUTION: Blades are sharp! Use extra care when removing, installing, or adjusting the saw blade!

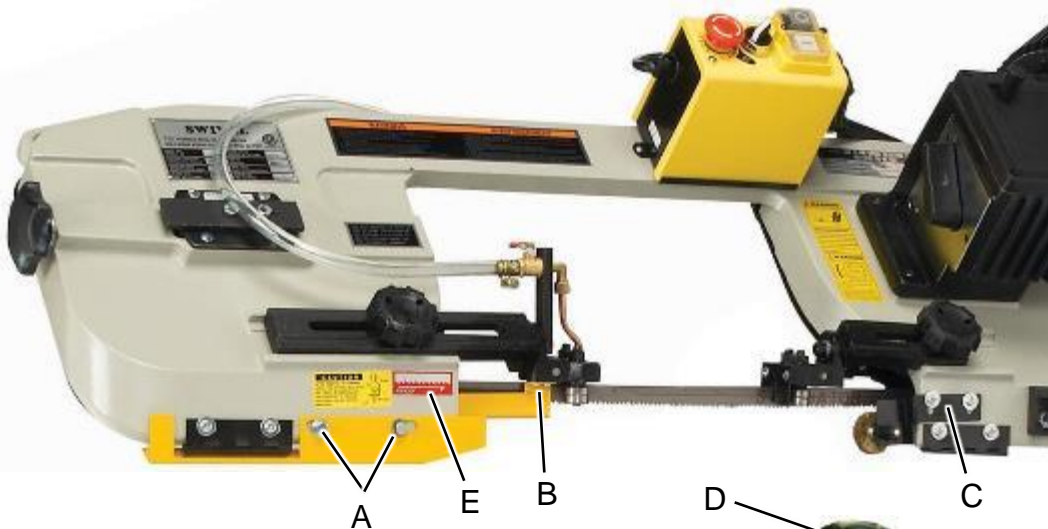

1. Disconnect the saw from the power source.
2. Remove the two hex bolts (A) and remove the bow cover guard to allow the blade cover to open fully.
3. Remove (2) screws (B) and take off the inner blade guard.
4. Loosen (2) screws (C) and remove the wire wheel.
5. Raise the saw bow to a vertical position and lock in place by turning the hydraulic cylinder off.
6. Remove the (2) screws and open the hinged blade guard.
7. Release the blade tension by turning the tension knob (D) counterclockwise (ccw).
8. With gloves on, carefully remove the old or broken blade.
9. Install the new blade by placing between the blade guides first. Use the indicator (E) to verify the correct direction to point the teeth.





10. Place the blade around both the drive pulley and the idler pulley. Make sure the back edge of the blade rests near the flange (F) on both pulleys.
11. Turn the blade tension knob (D) clockwise (cw) to tension the blade. DO NOT over tension. See the section titled "Adjusting Blade Tension".
12. Close the blade cover, secure with the (2) screws, and slide the drive pulley cover down.
13. Attach the wire wheel (C), the inner blade guard (B), and the blade cover guard (A).
14. Lower the saw bow by releasing the cylinder lever.
15. Connect to the power source.
16. Run the saw and make sure the blade is tracking properly.

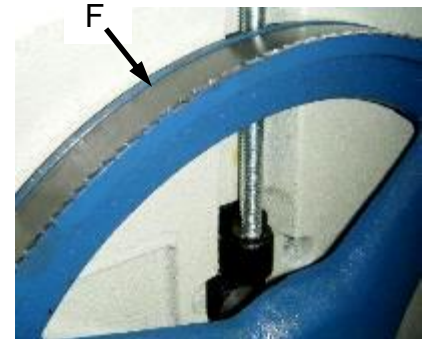

Adjusting Blade Guide Bearings

The blade guide bearings have been adjusted at the factory. Over time, an adjustment will become necessary due to uneven blade wear or skewed cuts. The side bearings have an eccentric shaft to allow for side to side adjustment.

1. Disconnect power to the saw.
2. Move the saw bow to the vertical position and lock in place by turning off the hydraulic cylinder valve.
3. Loosen cap screw (X) in figure at right and adjust the bearing assembly so that the back roller bearing is approximately .003"-.005" (.07mm - .13mm) from the back of the blade.
4. Turn nut(s) (Y) to adjust for a .001" - .002" (.02 - .05mm) side clearance between the bearing and the blade.
5. Repeat the procedure for the side clearance of the other bearing assembly. This assembly has no back bearing adjustment.
6. Blade should still move up and down freely after adjusting.

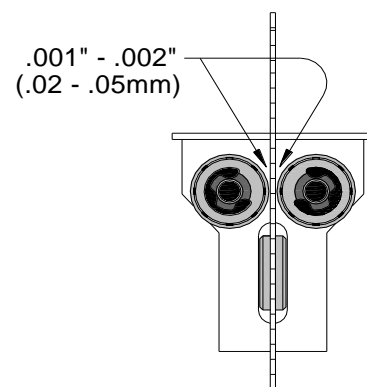
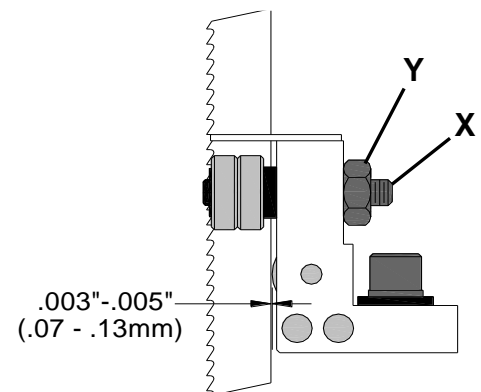



Adjusting Blade Tracking

⚠ CAUTION: Blades are sharp! Use extra care when removing, installing, or adjusting the saw blade! The blade tracking adjustment requires running the saw with the back cover open. This adjustment must be completed by qualified trained personnel. Failure to comply may cause serious personal injury!



Note: Before making any tracking adjustments, try a new blade. Warped blades will not track properly.

Blade tracking has been set at the factory and should not require adjusting. If a tracking issue occurs, adjust the machine as follows:

1. Move the saw bow to the vertical position and lock in place by turning off the hydraulic cylinder valve.
2. Confirm that the blade tension is set properly. To adjust, see the section titled “Adjusting Blade Tension”
3. Remove the (2) Screws and open the back cover after sliding up the drive pulley cover.
4. Run the saw and observe the blade. The blade should run close to, but not tightly against the pulley flange.
5. Loosen the two hex bolts (V) as indicated.
6. Turn setscrew (W) while observing blade tracking on the pulley. Turn the setscrew clockwise (cw) to track the blade closer to the pulley flange. Turn the setscrew counterclockwise (ccw) to track the blade away from the pulley flange.
7. Once the tracking is set, tighten the two hex bolts (V).

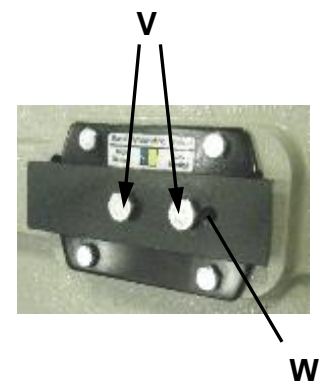



Changing Blade Speed

To change speeds from position 1 to 2 to 3.

1. Disconnect power to the saw.
2. Turn the handle on the reducer with one hand and use the other hand to slide the blade back and forth until the handle engages the required gear. (Wear proper hand protection.)
 - a. Speed 1, 145 FPM is used to cut tool steel, stainless steel, hard cast iron, alloy steel, and hard bronze.
 - b. Speed 2, 200 FPM is used to cut mild steel, soft cast iron, medium hard bronze, hard aluminum, and plastics.
 - c. Speed 3, 245 FPM is used to cut plastics, soft or medium soft aluminum, wood, and other light materials.
3. After the speed change, re-connect power to the saw.

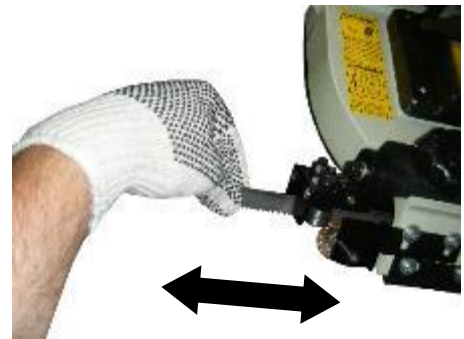

Note: There is also a speed selection chart posted above the gear box.

Vertical Cutting

⚠ CAUTION: AVOID TIP OVER! The saw bow must be in the 0° position before raising the bow to the vertical position. The Support Bar must be installed prior to using the saw in the vertical position.

1. Move the saw bow to the 0° position.
2. Raise the saw bow to the vertical position and lock in place by turning off the hydraulic cylinder valve.
3. Remove two screws (Z) and take off deflector plate (AA).
4. Slide the slot in the plate over the blade and attach the plate with the two screws removed in step 2.





PRIOR TO OPERATION

Read the section on adjusting the blade tension for the proper procedure.

1. Check to see if blade tooth direction matches the diagram on the saw body. 
2. Check to see that the blade is properly seated on the pulleys after setting the blade tension.
3. Set the blade guide roller bearings as described in the (adjustment section of this manual).
4. Position the front and rear blade guides as close as possible to the piece part. (Check for any interferences)
5. Set the proper speed and feed rate for the material being cut.
6. Make sure the piece part is held securely in the vise.
7. Check for adequate coolant in the reservoir.
8. DO NOT start the cut on a sharp edge. Break it down with a file.
9. Keep the saw adequately lubricated. (See the lubrication and maintenance section).

Hydraulic Feed Selector

The hydraulic feed selector is used to control the blade feed rate and to lock the saw bow in the vertical position.

- To increase the feed rate, turn the knob counterclockwise (ccw).
- To decrease the feed rate turn the knob clockwise (cw).
- To turn off the flow of hydraulic fluid, turn the lever counterclockwise (ccw).
- To turn the hydraulic cylinder on, turn the lever clockwise (cw).

⚠ WARNING

IMPORTANT
DO NOT OPERATE BEFORE READING

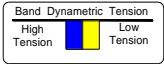
1. For shipping purposes only the tension on the blade has been reduced. Before attempting to cut any materials you must re-adjust the blade to the proper tension.
2. A new label indicates the tension strength. For proper tension the indicator mark on the tension plate should line up with the center of the blue area.

3. A break-in period is strongly advised for maximum blade life. Run the blade at a feed pressure reduced by one-third for the first 50 square inches of cutting. If you are cutting material with strong work hardening characteristics, Apply enough extra feed pressure to take a good chip.

HYDRAULIC FEED CONTROL

⚠ WARNING

NEVER FORCE THE BANDSAW UP OR DOWN: doing so may cause the unit to tip or may cause this cylinder to fail, resulting in injury. Refer to manual for instructions BEFORE setup or use.

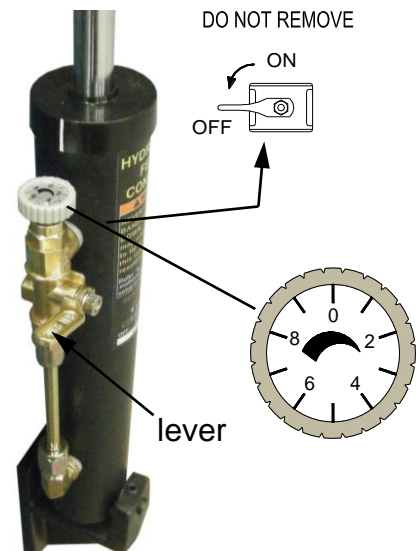
DO NOT REMOVE





OPERATION

⚠ CAUTION: Always wear proper eye protection with side shields, safety footwear, and leather gloves to protect from burrs and sharp edges. When handling large heavy materials make sure they are properly supported. NEVER operate saw without blade guards in place.

1. Select and set the proper blade speed for the material being cut.
2. Connect power to the saw.
3. Reset the “E”-Stop button.

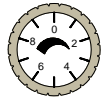

4. Turn the feed rate knob clockwise (cw) to close.



5. Turn the cylinder valve to the “ON” clockwise (cw) position.

6. Adjust the blade guide assemblies for the size of the material.
7. Use the handle to raise the saw bow to approximately 45°.
8. Place material onto the base of the vise, set the material stop, and clamp the material securely.
9. Start the saw motor by pressing the Black “O” start button.



10. Slowly open the feed rate knob counterclockwise (ccw) to start the bow descent.

11. Start the coolant flow (slowly) by turning the brass valve counterclockwise (ccw.)

12. When the cut is finished, the saw motor and coolant pump will shut off.

13. Raise the saw bow for the next cut.

14. Turn the cylinder valve to the “OFF” counterclockwise (ccw) position to stop the bow descent.

15. Advance the material in the vise and secure it.

16. Press the Black “O” start button.



17. Turn the cylinder valve to the “ON” clockwise (cw) position to start the bow descent.



LUBRICATION AND MAINTENANCE

⚠ WARNING: Make sure the electrical disconnect is OFF before working on the machine.

Maintenance should be performed on a regular basis by qualified personnel. Always follow proper safety precautions when working on or around any machinery.

Daily Maintenance

- Check daily for any unsafe conditions and fix immediately.
- Check that all nuts and bolts are properly tightened.
- Do a general cleaning by removing dust and metal chips from the machine.
- Inspect the saw blade for wear.
- Top off the coolant tank.
- Clean the lubricating coolant drain screen.
- Check that the blade guards and emergency stop button are in good working order.
- When through using machine, raise the saw head to its up position and release some tension on the saw blade.

Weekly Maintenance

- On a weekly basis clean the machine and the area around it.
- Lubricate threaded components and sliding devices.
- Apply rust inhibitive lubricant to all non-painted surfaces.
- Thoroughly clean the machine.
- Wipe and re-grease the vise screw and sliding surfaces.
- Remove chips from inside the guard housing for the saw blade.
- Use compressed air to clean the blade guides and guide bearings.

Monthly Maintenance

- Check the blade guide bearings for wear. (replace if necessary)
- Tighten any loose bolts or screws on the gear motor, pump, and safety switches.
- Clean coolant tank



Six Month Maintenance

- Do a continuity check of the safety circuit

Machine Lubrication

- Ball bearings on the blade guide assemblies and the blade wheels are permanently sealed and require no further lubrication.
- Lightly lubricate the vise screw with a #2 lubricating grease.

Accessing and Cleaning the Coolant System

1. Disconnect power from the saw
2. Remove the vinyl hose (AB) from the strainer basket and pull off of the drain fitting.
3. Carefully remove the tank from the base of the saw.
4. Remove the strainer basket (AC) and pour out the old coolant from the tank.
5. Wash out any dirt and debris.
6. Clean and replace the strainer basket.
7. Refill the tank with coolant to 80% capacity.
8. Place the tank back into the base and re-connect the drain hose.

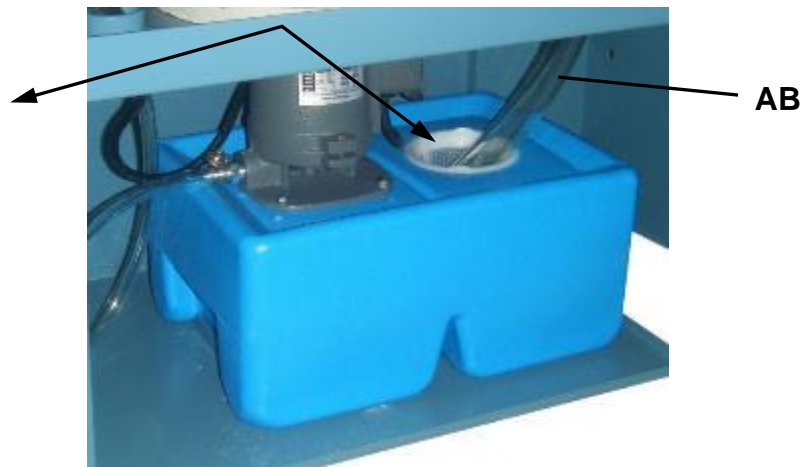



Gearbox Maintenance

The gearbox requires periodic changing of the oil. Initially after 6 months and then every year thereafter. Follow the procedure below:

1. Disconnect power from the saw
2. Raise the saw bow to a vertical position.
3. Remove the oil drain plug (AD) and drain the oil into a catch basin. Loosening oil fill plug (AE) will help oil to drain.
4. After draining, replace drain plug (AD).
5. Return the saw bow to a horizontal position.
6. Remove the fill plug (AE) and add 2 pints (.95 liter) of gear oil. (For reference use SHELL type gear oil or Mobil gear oil #90).

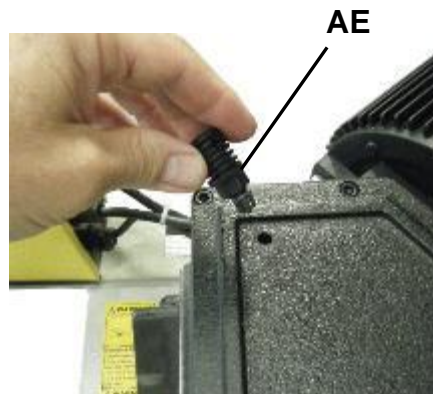
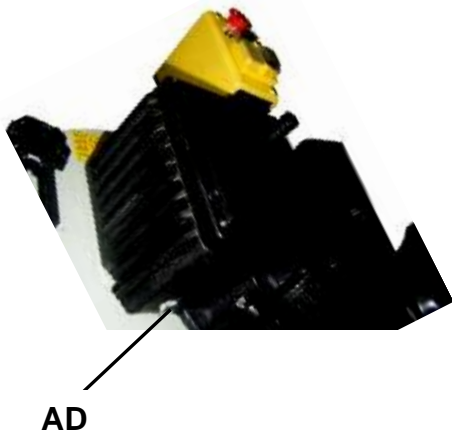

Oils for Lubricating Coolant

Any 10:1 (water to coolant) solution will work, however we recommend Baileigh Industrial B-Cool 20:1 (water to coolant) biodegradable metal cutting fluid. It has excellent cooling and heat transfer characteristics, is non-flammable, and extends tool and machine life. Each gallon of concentrate makes 21 gallons of coolant.

Storing Machine for Extended Period of Time

If this machine is to be inactive for a long period of time, prepare the machine as follows:

- Disconnect the electrical supply from the power panel.
- Empty and clean the coolant reservoir.
- Clean and grease the machine.
- Cover the machine.



PARTS DIAGRAM - A

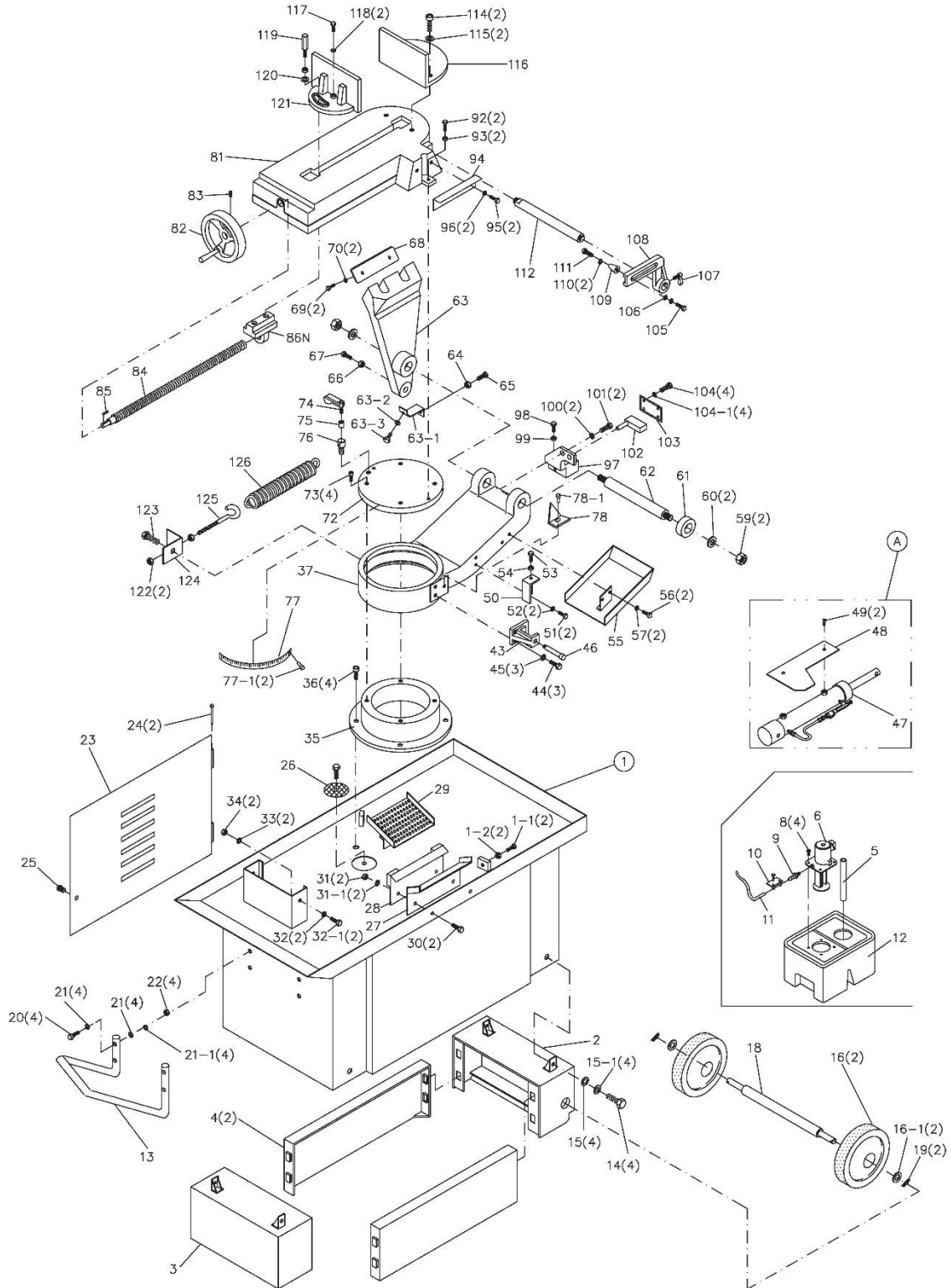



Parts List For "A" And "B"

Index No	Part No.	Description	Size	Q'ty
1	BS712MS-1	Bottom Dish		1
1-1	TS-0060071	Hex Cap Screw	3/8" x 1-1/2"	2
1-2	TS-0570031	Hex Nut	3/8"	2
2	BS712MS-2	Feet-Stand (Right)		1
3	BS712MS-3	Feet-Stand (Left)		1
4	BS712MS-4	Panel		2
5	BS712MS-5	Hose	1"	1
6	BS712MS-6	Coolant Pump	1/8 Hp 120/240V	1
8	TS-0050011	Hex Cap Screw	1/4" x 1/2"	4
9	BS712MS-9	Hose Fitting		1
10	BS712MS-10	Hose Clamp		1
11	BS712MS-11	Hose	5/16"	1
12	BS712MS-12	Coolant Tank	6L	1
13	BS712MS-13	Hand		1
14	TS-0081031	Hex Cap Screw	5/16" x 3/4"	4
15	TS-0680031	Flat Washer	5/16"	4
15-1	TS-0720081	Spring Washer	5/16"	4
16	BS712MS-16	Wheel	8"	2
16-1	TS-0680061	Flat Washer		2
18	BS712MS-18	Wheel Shaft		1
19	BS712MS-19	Spring Pin		2
20	TS-0051071	Hex Cap Screw	5/16" x 1-1/2"	4
21	TS-0680031	Flat Washer	5/16"	8
21-1	TS-0720081	Spring Washer	5/16"	4
22	TS-0561021	Hex Nut	5/16"	4
23	BS712MS-23	Door		1
24	BS712MS-24	Pin		2
25	BS712MS-25	Lock Knob	1/4x1	1
26	BS712MS-26	Filter		1
27	BS712MS-27	Bracket		1
28	BS712MS-28	Bracket		1
29	BS712MS-29	Chip Guide Plate		1
30	TS-0081031	Hex Cap Screw	5/16" x 3/4"	2
31	TS-0561021	Hex Nut	5/16"	2
31-1	TS-0720081	Spring Washer	5/16"	2



Index No	Part No.	Description	Size	Q'ty
32	TS-0680031	Flat Washer	5/16"	2
32-1	TS-0081051	Hex Cap Screw	5/16" x 1"	2
33	TS-0720081	Spring Washer	5/16"	2
34	TS-0561021	Hex Nut	5/16"	2
35	BS712MS-35	Low Base Of Disc		1
36	TS-1505021	Socket Head Cap Screw	M10 x 20	4
37	BS712MS-37	Swivel Base		1
43	BS712MS-43	Bottom Support		1
44	TS-0081051	Hex Cap Screw	5/16" x 1"	3
45	TS-0720081	Spring Washer	5/16"	3
46	BS712MS-46	Support Rod		1
47	BS712MS-47	Hydraulic Cylinder		1
48	BS712MS-48	Cylinder Cover		1
49	BS712MS-49	Round Hd. Screw	1/4x3/8	2
50	BS712MS-50	Support Plate		1
51	TS-0081051	Hex Cap Screw	5/16" x 1"	2
52	TS-0720081	Spring Washer	5/16"	2
53	TS-1492041	Hex Cap Screw	M12x40	1
54	TS-1540081	Hex Nut	M12	1
55	BS712MS-55	Splash Guard		1
56	TS-0081031	Hex Cap Screw	5/16" x 3/4"	2
57	TS-0720081	Spring Washer	5/16"	2
59	BS712MS-59	Nylon Nut	M18	2
60	BS712MS-60	Washer		2
61	BS712MS-61	Bushing		1
62	BS712MS-62	Support Shaft		1
63	BS712MS-63	Pivot Arm		1
63-1	BS712MS-63-1	Bracket		1
63-2	TS-0720081	Spring Washer	5/16"	1
63-3	TS-0051011	Hex. Hd. Screw	5/16" x 1/2"	1
64	TS-0561021	Hex Nut	5/16"	1
65	TS-0081051	Hex Cap Screw	5/16" x 1"	1
66	TS-0570031	Hex Nut	3/8"	1
67	TS-0060081	Hex Cap Screw	3/8" x 1-3/4"	1
68	BS712MS-68	Plate		1
69	TS-0060071	Hex Cap Screw	3/8" x 1-1/2"	2



Index No	Part No.	Description	Size	Q'ty
70	TS-0720091	Spring Washer	3/8"	2
72	BS712MS-72	Upper Of Disc		1
73	TS-1505021	Socket Head Cap Screw	M10x20	4
74	BS712MS-74	Lock Handle	3/8x45	1
75	BS712MS-75	Bronze Bushing		1
76	BS712MS-76	Thrust Shaft		1
77	BS712MS-77	Scale		1
77-1	BS712MS-77-1	Rivet	2.3x4mm	2
78	BS712MS-78	Angle Indicator		1
78-1	BS712MS-78-1	Rivet	2.3x4mm	1
81	BS712MS-81	Table		1
82	BS712MS-82	Handle Wheel Assembly		1
83	TS-0270031	Set Screw	5/16" x 3/8"	1
84	BS712MS-84	Lead Screw		1
85	BS712MS-85	Key	5x5x20	1
86N	BS712MS-86N	Lead Screw Bracket		1
92	TS-1506031	Socket Head Cap Screw	M12 x 30	2
93	BS712MS-93	Spring Washer	M6	2
94	BS712MS-94	Top Support		1
95	TS-0081031	Hex Cap Screw	5/16" x 3/4"	2
96	TS-0720081	Spring Washer	5/16"	2
97	BS712MS-97	90° Support		1
98	TS-1491061	Hex Cap Screw	M10 x 40	1
99	TS-1540071	Hex Nut	M10	1
100	TS-0720091	Spring Washer	3/8"	2
101	TS-0060061	Hex Cap Screw	3/8" x 1-1/4"	2
102	BS712MS-102	Limit Switch		1
103	BS712MS-103	Limit Switch Cover		1
104	TS-1501021	Hex. Socket Cap Screw	M4x8	4
104-1	BS712MS-104-1	Spring Washer	M4	4
105	TS-0081031	Hex Cap Screw	5/16" x 3/4"	1
106	TS-0680031	Flat Washer	5/16"	1
107	BS712MS-107	Thumb Screw		1
108	BS712MS-108	Stop Bracket		1
109	BS712MS-109	Work Stop		1
110	TS-0561021	Hex Nut	5/16"	1



Index No	Part No.	Description	Size	Q'ty
111	TS-0081031	Hex Cap Screw	5/16" x 3/4"	1
112	BS712MS-112	Stop Rod		1
114	TS-1492031	Hex Cap Screw	M12 x 35	2
115	TS-0720111	Spring Washer	1/2"	2
116	BS712MS-116	Rear Vise		1
117	TS-0060071	Hex Cap Screw	3/8" x 1-1/2"	1
118	TS-0720091	Spring Washer	3/8"	2
119	BS712MS-119	Screw Handle		1
120	BS712MS-120	Washer	3/8"x27x3	1
121	BS712MS-121	Front Vise		1
122	TS-0570031	Hex Nut	3/8"	2
123	TS-0060031	Hex Cap Screw	3/8" x 3/4"	1
124	BS712MS-124	Spring Bracket		1
125	BS712MS-125	Spring Adjusting Rod	3/8"x130mm	1
126	BS712MS-126	Spring		1
127	BS712MS-127	Saw Bow		1
127-1	TS-0051061	Hex Cap Screw	5/16" x 1-1/4"	4
127-2	TS-0720081	Spring Washer	5/16"	4
127-3	TS-0267042	Adjust Screw	1/4" x 3/8"	2
129	BS712MS-129	Vent Plug		1
130	BS712MS-130	Key	6x20	1
131	BS712MS-131	Hex Cap Screw	3/8" x 7/8"	1
131-1	TS-0720091	Spring Washer	3/8"	1
131-2	TS-0680041	Flat Washer	3/8"	1
133	BS712MS-133	Blade Wheel (Rear)		1
134	BS712MS-134	Blade	19x0.9x2360 5/8T	1
135	BS712MS-135	Blade Back Cover		1
136	BS712MS-136	Wheel Cover		1
137	BS712MS-137	Plum Screw		2
137-1	TS-0680021	Flat Washer	1/4"	2
138	TS-0680021	Flat Washer	1/4"	4
139	BS712MS-139	Round Hd. Screw	1/4x1/2	4
140	BS712MS-140	Guide Adjustable Knob	3/8"x1-1/4"	2
141	BS712MS-141	Adjustable Bracket (Rear)		1
142	BB-608ZZ	Ball Bearing	608ZZ	2
143	BS712MS-143	Bearing Pin	8MM	2



Index No	Part No.	Description	Size	Q'ty
144	BS712MS-144	Blade Adjustable Seat (Rear)		1
144-1	BS712MS-144-1	Blade Adjustable Seat (Front)		1
145	TS-0561032	Hex Nut	3/8"-24UNF	4
145-1	TS-0720091	Spring Washer	3/8"	4
146	BS712MS-146	Eccentric Shaft Assembly		2
146-1	BS712MS-146-1	Center Shaft Assembly		2
147	BS712MS-147	Vertical Cutting Plate	Option	1
147-1	BS712MS-147-1	Vertical Cutting Plate (Small)		1
147-2	TS-081F031	Flat Head Screw	1/4" x 1/2"	2
148	BS712MS-148	Magnetic Switch		1
149	BS712MS-149	Washer	5/16"	2
150	BS712MS-150	Spring Washer	5/16"	2
151	BS712MS-151	Hex. Soc. Screw	5/16x1-1/8	2
152	BS712MS-152	Top Support		1
153	BS712MS-153	Hex. Hd. Screw	3/8x1-1/4	2
154	TS-0720091	Spring Washer	3/8"	2
155	TS-0570031	Hex Nut	3/8"	2
156	BS712MS-156	Round Hd. Screw	1/4x1/2	2
157	TS-0680021	Flat Washer	1/4"	2
158	BS712MS-158	Brush Holder		1
159	TS-0267021	Socket Set Screw	1/4" x 1/4"	1
160	BS712MS-160	Fixed Bushing		1
161	BS712MS-161	Brush	1-1/2"x6MM	1
162	BS712MS-162	Support Rod		1
163	BS712MS-163	Nozzle Cock		1
164	BS712MS-164	Nozzle Cock Support		1
165	TS-0267051	Socket Set Screw	1/4" x 1/2"	1
166	BS712MS-166	Socket Head Cap Screw	5/16x1-1/8	1
166-1	TS-0720081	Spring Washer	5/16"	1
167	TS-0208061	Socket Head Cap Screw	5/16x1	1
168	TS-0720081	Spring Washer	5/16"	1
169	BS712MS-169	Washer	5/16"	1
170	BS712MS-170	Valve		1
171	BS712MS-171	Hose Clamp	13MM	1
172	BS712MS-172	Bracket		1
172-1	TS-0050011	Hex Cap Screw	1/4" x 1/2"	1



Index No	Part No.	Description	Size	Q'ty
172-2	TS-0720071	Spring Washer	1/4"	1
172-3	TS-0680021	Flat Washer	1/4"	1
173	BS712MS-173	Adjustable Bracket (Front)		1
174	BS712MS-174	Blade Guard		1
175	BS712MS-175	Round Hd. Screw	3/16"x1/4"	2
176	BS712MS-176	Sliding Guide Plate		2
177	TS-0050011	Hex Cap Screw	1/4" x 1/2"	4
178	BS712MS-178	Blade Tension Sliding Block		1
179	TS-0270071	Socket Set Screw	5/16" x 3/4"	1
180	TS-0051071	Hex Cap Screw	5/16" x 1-1/2"	2
181	BS712MS-181	Sliding Draw Block		1
182	BS712MS-182	Bearing Bushing		1
183	BB-6203ZZ	Ball Bearing	6203ZZ	2
184	BS712MS-184	Blade Wheel (Front)		1
185	TS-0680031	Flat Washer	5/16"	1
185-1	TS-0720081	Spring Washer	5/16"	1
186	TS-0081031	Hex Cap Screw	5/16" x 3/4"	1
187	TS-0680041	Flat Washer	3/8"	1
188	BS712MS-188	Guide Adjustable Knob		1
189	BS712MS-189	Support Plate		1
190	TS-0680021	Flat Washer	1/4"	2
191	BS712MS-191	Hex Cap Screw	1/4"x3/8"	2
192-1	BS712MS-192-1	Motor	1 Hp 120/240V	1
192-2	BS712MS-192-2	Strain Relief		1
192-3	TS-1490041	Hex Cap Screw	M8x25	2
192-4	TS-2361081	Spring Washer	8 mm	2
193	BS712MS-193	Key	5 mm	1
194-1	BS712MS-194-1	Worm Shaft		1
195-1	BS712MS-195-1	Gear Flange		1
195-2	TS-1503051	Socket Head Cap Screw	M6x20	1
196N	BS712MS-196N	Gear Box		1
197	BS712MS-197	Splash Guard (Front)		1
198	BS712MS-198	Flat Washer	1/4"	2
199	BS712MS-199	Spring Washer	1/4"	2
200	TS-0050011	Hex Cap Screw	1/4"x1/2"	2



ELECTRICAL COMPONENTS

Item	Description and function	Technical data	Remark
KM	Magnetic Contactor	AC1 – 12A, 600V	CNS 2930 BS 775
FR	Overload Relay	12.0 ~ 18.0/14A, 1x115VAC	TH-12
SQ1	Cut off limit switch	250VAC, 10A	UL
SB1	Push-Button Emergency Stop	300VAC, 3.0A 125VAC, 6.0A	CSA
SB2	Push-Button Off	AP11	
SB3	Push-Button On	AP11	
SA	Coolant Pump On/Off Switch	1 for 1 phase 600VAC, max.	VDE UL E5579

WIRING DIAGRAM

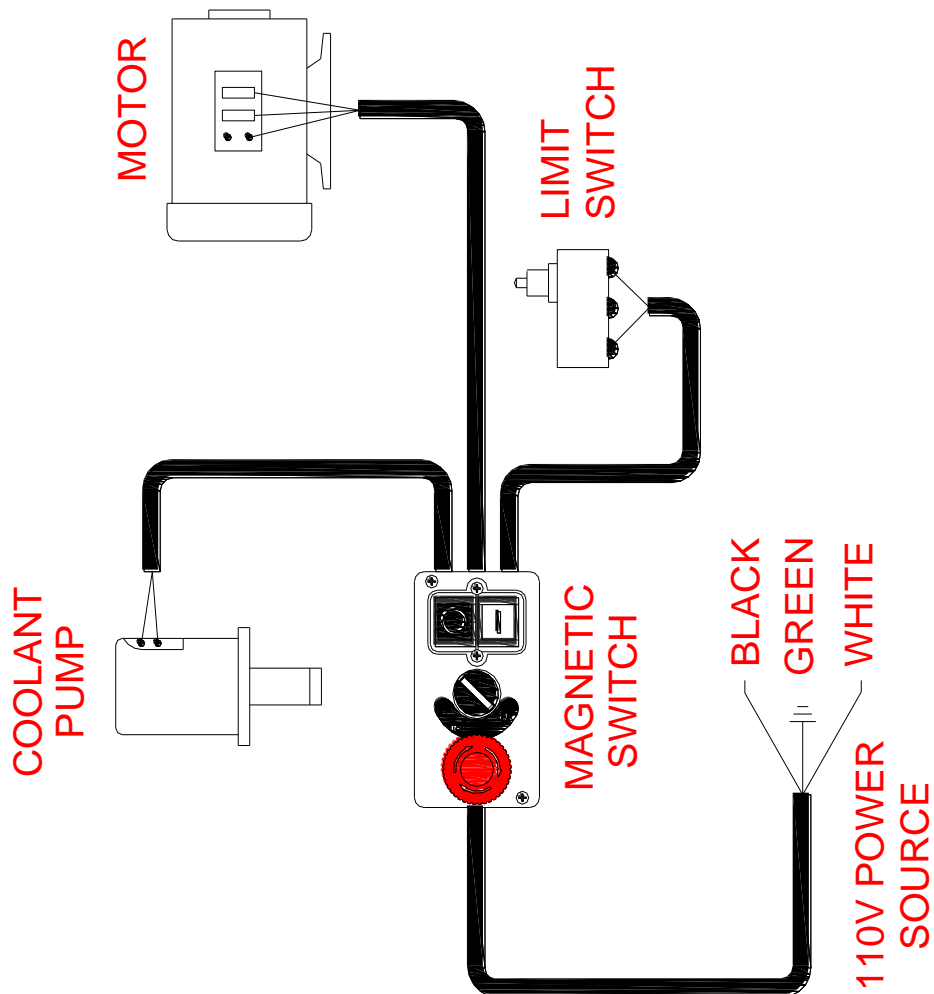



ELECTRICAL SCHEMATIC

1 ph (RECOM)
60Hz 10A gL type

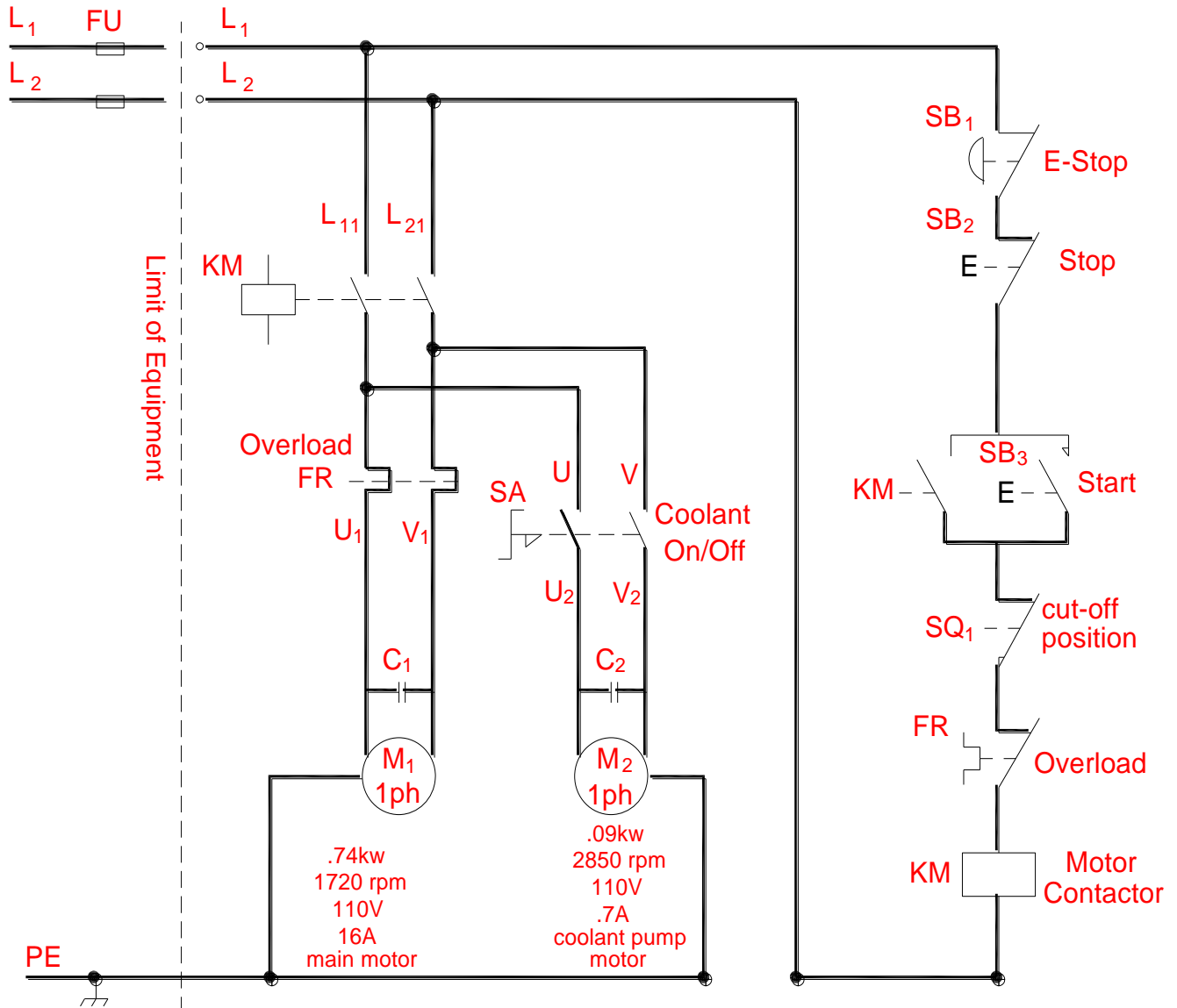



TROUBLESHOOTING

⚠ WARNING: Make sure the electrical disconnect is **OFF** before working on the machine.

SYMPTOM	POSSIBLE CAUSE (S)	CORRECTIVE ACTION
The Blade Drive Motor Does Not Work	<ol style="list-style-type: none"> 1. E-stop pushed. 2. No power at the electrical outlet 3. Motor burned out. 	<ol style="list-style-type: none"> 1. Twist the button (cw) to reset or replace the switch. 2. Have electrician check breaker or fuses. 3. Have motor repaired or replaced.
Excessive Blade Breakage	<ol style="list-style-type: none"> 1. Incorrect blade tension. 2. Incorrect speed or feed. 3. Material loose in vise. 4. Blade rubs on wheel flange. 5. Teeth too coarse for material. 6. Teeth in contact with the material before the saw is started. 7. Misaligned guides. 8. Blade too thick for wheel diameter. 9. Cracking of blade weld. 	<ol style="list-style-type: none"> 1. Adjust to where blade just does not slip-on wheel. 2. Consult machine chart or handbook. 3. Clamp work securely. 4. Adjust the wheel alignment. 5. Contact Baileigh Industrial for recommended blade type. 6. Contact material after blade has been started. 7. Adjust as necessary. 8. Select a thinner blade (.035" x .75" recommended). 9. Make longer annealing cycle
Teeth Ripping from Blade	<ol style="list-style-type: none"> 1. Tooth too coarse for work. 2. Too heavy feed / too slow feed. 3. Vibrating piece part. 4. Gullets loading with chips and debris. 	<ol style="list-style-type: none"> 1. Use a fine-tooth blade. 2. Increase feed pressure and / or speed. 3. Make sure work is clamped securely. 4. Use coarser tooth blade or brush to remove chips and debris.
Premature Blade Dulling.	<ol style="list-style-type: none"> 1. Teeth too coarse. 2. Too much speed. 3. Inadequate feed pressure. 4. Hard spots in or on material. 	<ol style="list-style-type: none"> 1. Use a finer tooth blade. 2. Try next slower speed. 3. Decrease spring tension on side of saw. 4. Scale: Reduce speed, increase feed pressure. Hard spots: Increase feed pressure.



SYMPTOM	POSSIBLE CAUSE (S)	CORRECTIVE ACTION
	5. Work hardening of material (especially stainless steel). 6. Blade installed backwards. 7. Insufficient blade tension.	5. Increase feed pressure by reducing spring tension. 6. Remove blade twist inside out and reinstall blade. 7. Increase tension to proper setting.
Bad Cuts (Crooked)	1. Work not square. 2. Feed pressure too great. 3. Guide bearing not adjusted properly. 4. Inadequate blade tension. 5. Blade guides spaced out too far. 6. Dull blade. 7. Speed incorrect. 8. Blade guide assembly loose. 9. Blade guide bearing assembly loose. 10. Blade tracks too far away from wheel flanges.	1. Adjust vise to be square with blade. 2. Reduce pressure by increasing spring tension on side of saw. 3. Adjust guide bearing to .001" greater than max. thickness, including weld of the saw blade. 4. Increase blade tension a little at a time. (Center of blue area on label.) 5. Move guide as close to work as possible without interference. 6. Replace blade. 7. Check manual for recommended speeds. 8. Tighten. 9. Tighten. 10. Re-adjust tracking per instructions in this manual.
Saw Motor Does Not Stop When Cut is Finished	1. Actuator on cylinder does not contact switch properly.	1. Re-adjust actuator or switch.
Coolant Motor Does Not Run with Band Saw Motor	1. Coolant motor M2 damaged.	1. Replace M2 motor.
Blade Cuts (Rough)	1. Too much speed or feed. 2. Blade is too coarse.	1. Reduce speed and feed. 2. Replace with a finer blade.
Blade is Twisting	1. Cut is causing the blade to bind. 2. Too much blade tension.	1. Decrease the feed pressure. 2. Decrease the blade tension.
Unusual Wear on Side/Back of Blade	1. Blade guides worn. 2. Blade guide bearings not adjusted properly. 3. Blade guide bearing bracket is loose.	1. Replace blade guides. 2. Adjust as per operator's manual. 3. Tighten bracket



SYMPTOM	POSSIBLE CAUSE (S)	CORRECTIVE ACTION
Motor Running too Hot	<ol style="list-style-type: none">1. Blade tension is too high.2. Blade is too coarse for work (especially pipes).3. Blade is too fine for work. (Heavier, soft, materials.4. Gears need lubrication.5. Idler wheel needs lubrication	<ol style="list-style-type: none">1. Reduce tension on blade.2. Use finer blade.3. Use coarser blade.4. Check oil bath.5. Oil bearing/shaft on idler wheel.
No Coolant at Nozzle	<ol style="list-style-type: none">1. Valve not open.2. Insufficient coolant.3. Coolant motor burned out.4. Plugged coolant line	<ol style="list-style-type: none">1. Open valve.2. Fill to 80% capacity.3. Replace motor.4. Unplug line.

NOTES



BAILEIGH INDUSTRIAL
1625 DUFEK DRIVE MANITOWOC, WI 54220
PHONE: 920. 684. 4990 FAX: 920. 684. 3944
www.baileigh.com