

8 7 6 5 4 3 2 1

D

D

C

C

B

B

A

A

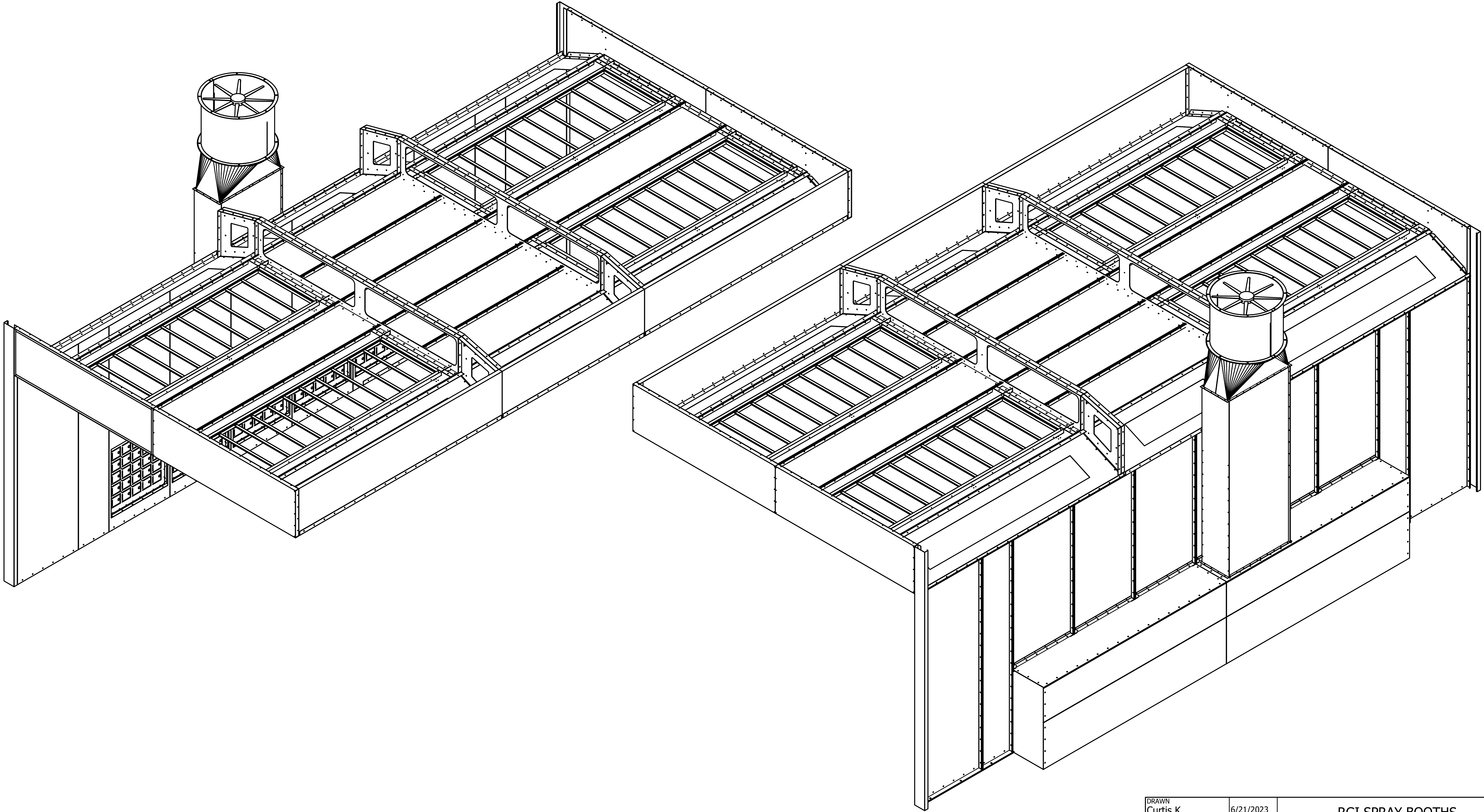

THIS DOCUMENT CONTAINS CONFIDENTIAL AND PROPRIETARY INFORMATION THAT CANNOT BE REPRODUCED OR DIVULGED, IN WHOLE OR IN PART, WITHOUT WRITTEN AUTHORIZATION FROM RGI SPRAY BOOTHS

DRAWN Curtis K	6/21/2023	RGI SPRAY BOOTHS	
CHECKED		TITLE	
QA		DELTA PREP STATION	
MFG		27'L X 14'W X 9'H	
APPROVED		PART #	DWG NO
			DELTA PREP STATION 14W X 27L X
		SCALE	SHEET 1 OF 6
		1 / 20	

8 7 6 5 4 3 2 1

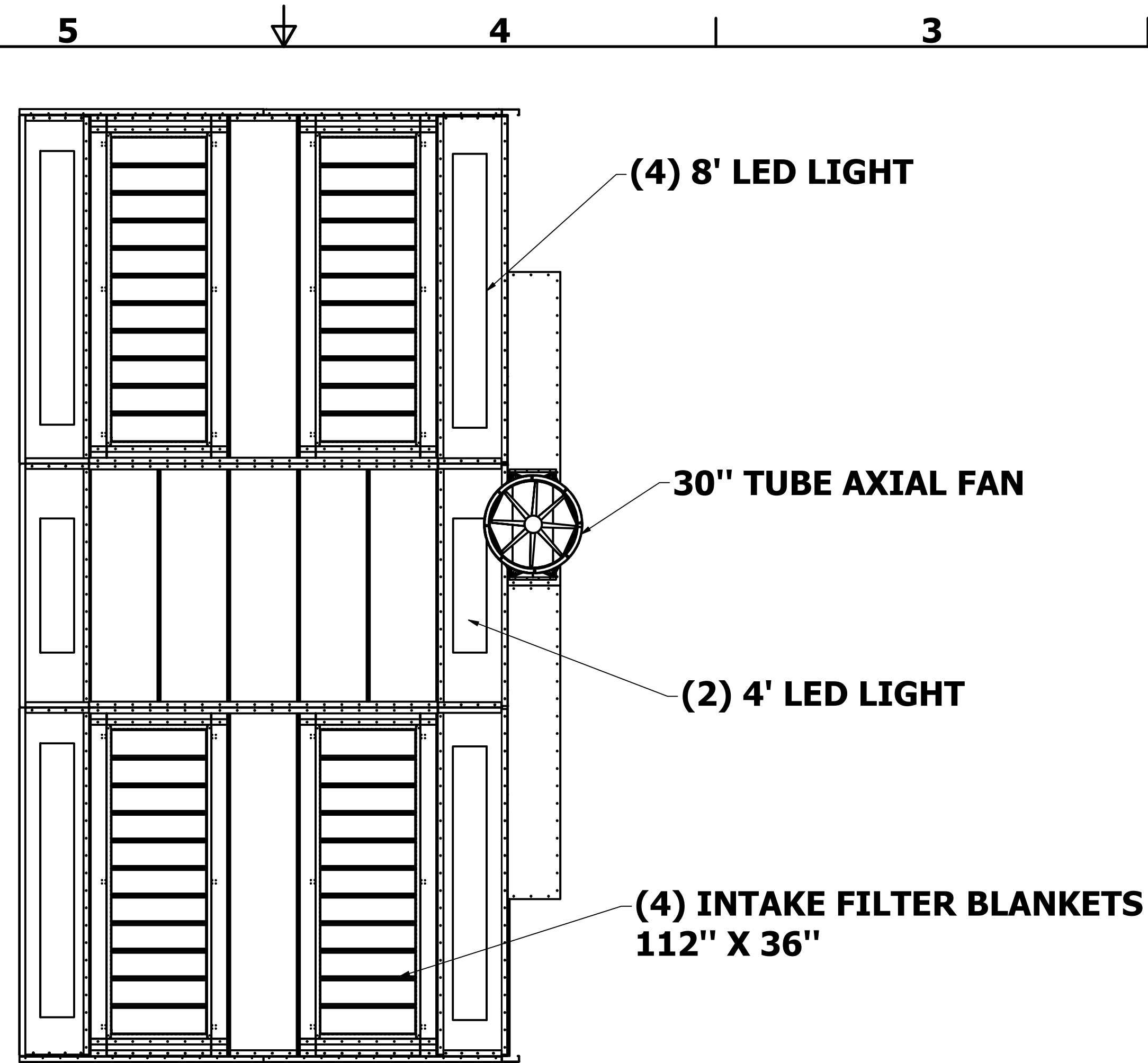
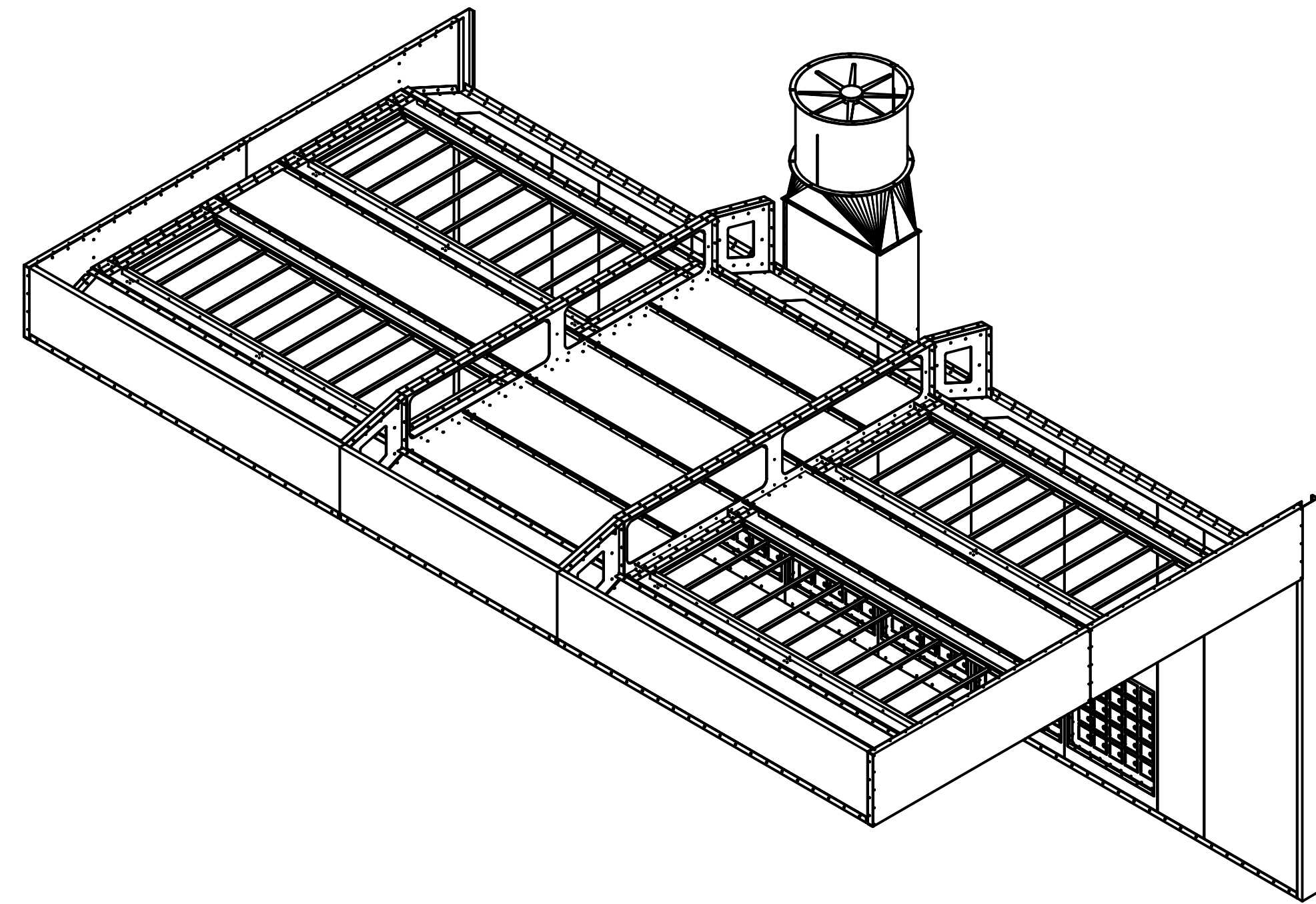

(6) EXHAUST FILTERS
36" X 36"

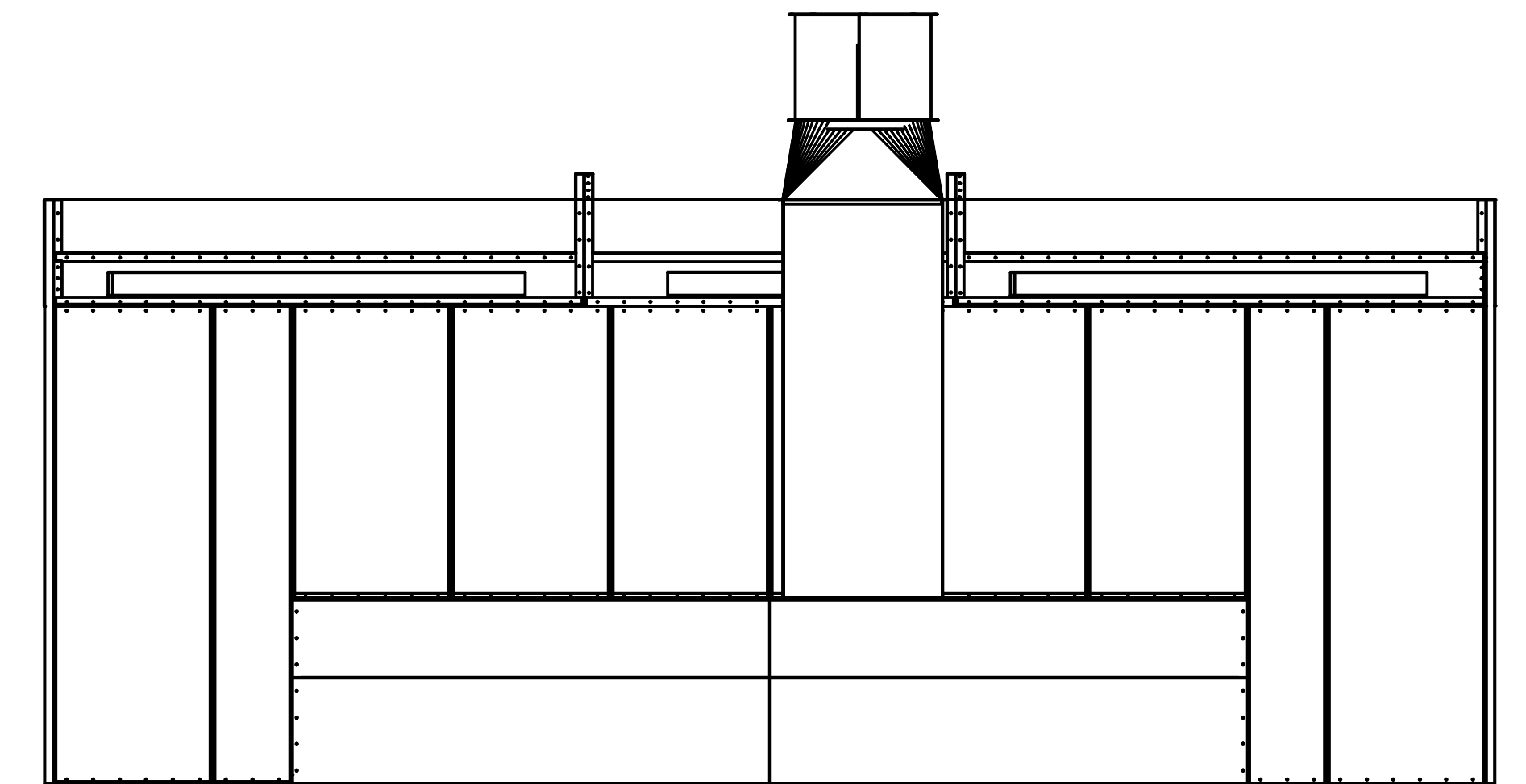
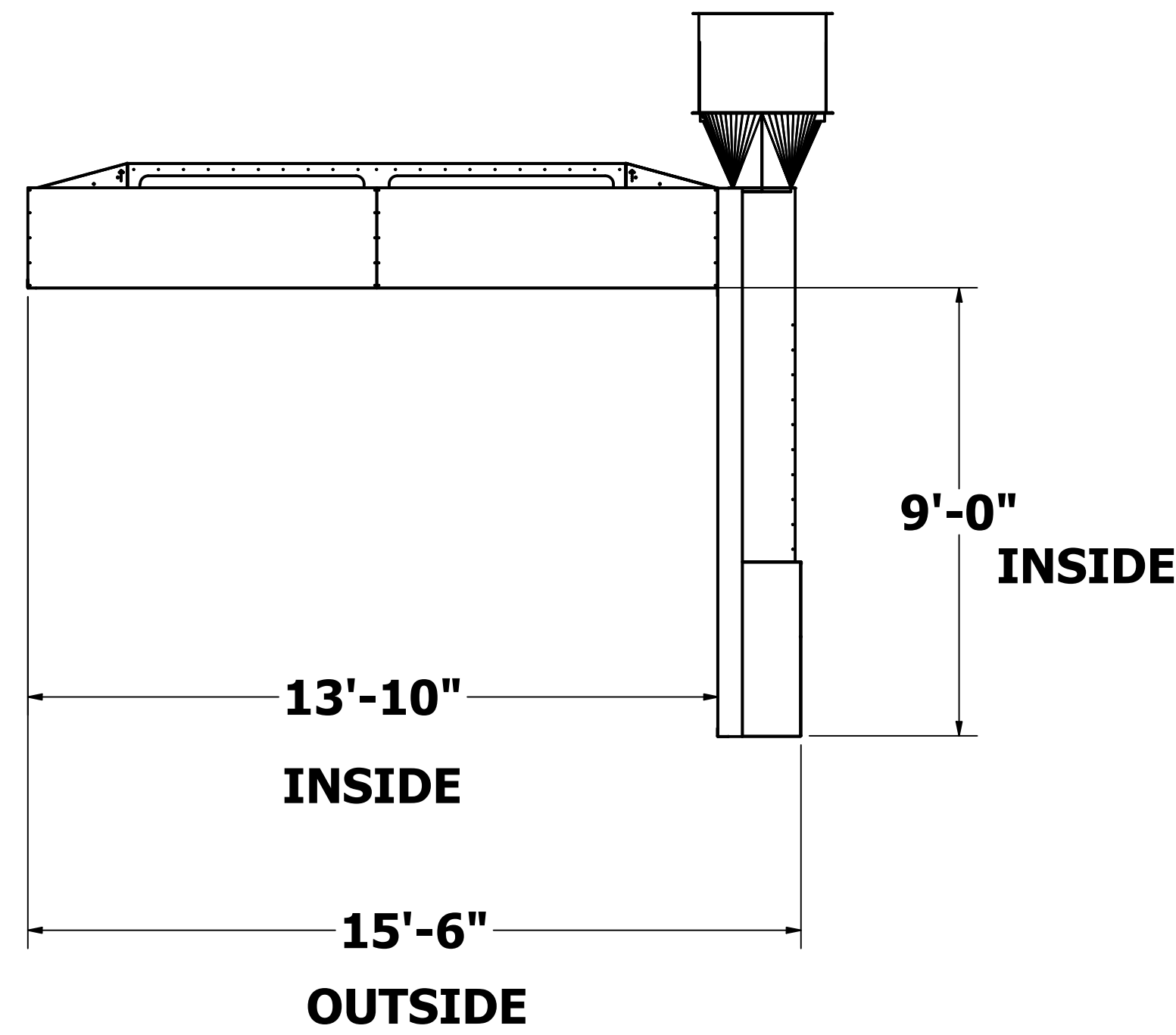
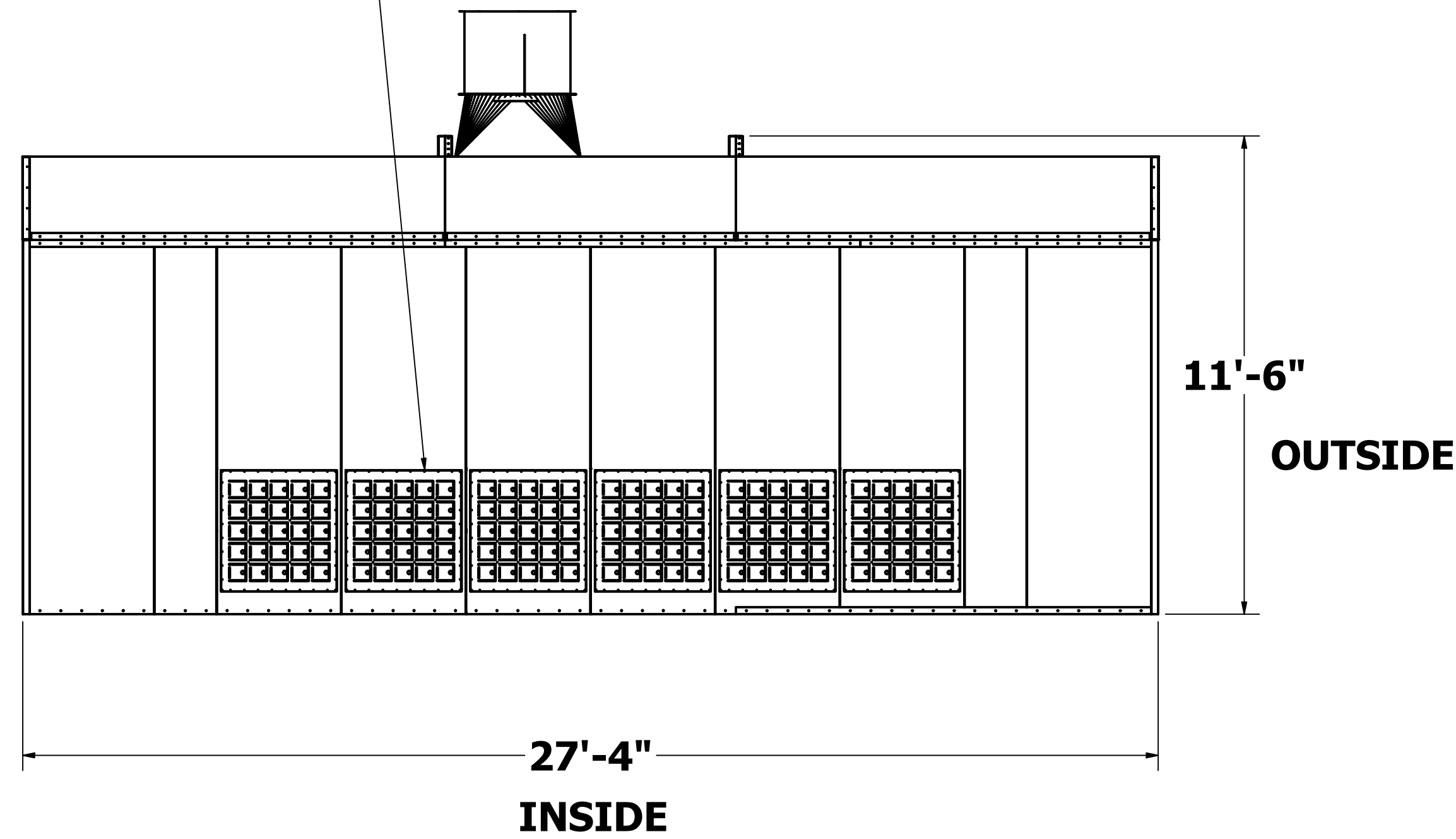

DRAWN Curtis K	6/21/2023	RGI SPRAY BOOTHS	
CHECKED		TITLE	
QA		DELTA PREP STATION	
MFG		27'L X 14'W X 9'H	
APPROVED		PART #	DWG NO
		SCALE	REV
		1 / 35	DELTA PREP STATION 14W X 27L X
		SHEET	2 OF 6

PARTS LIST			
ITEM	QTY	PART NUMBER	DESCRIPTION
F120	2	FLOOR CHANNEL 120 NEW DESIGN	
F84	1	FLOOR CHANNEL 84	
Z120	2	Z CHANNEL 120	
Z84	1	Z CHANNEL 84	
A120	2	ANGLE 2 X 2 X 120	
PS17	2	PREP STATION SIDE FASCIA 120 X 24	
PS58	4	ANGLE 2 X 2 X 24 FACE PANEL PREP STATION	
PS40	1	PREP STATION FACE INSIDE SKIN RIGHT 84 X 24	
PS63	2	PREP STATION GABLE 84 WITH LIGHT	
PS72	1	PREP STATION SIDE FASCIA 84 X 24	
PS37	1	SEMA PREP STATION FACE INSIDE SKIN LEFT 82 X 24	
PS41	1	SEMA PREP STATION FACE INSIDE SKIN LEFT 84 X 24	
PS36	1	SEMA PREP STATION FACE INSIDE SKIN RIGHT 82 X 24	
PS38	2	SEMA PREP STATION FACE OUTSIDE SKIN 84 X 24	
PS73	2	PREP STATION FACE OUTSIDE SKIN 82 X 24_REV 2	
PS32	4	PREP STATION GABLE 120 WITH 8' LIGHT	
PS95	1	PREP STATION FRONT PANEL 132X6 RIGHT	
PS96	1	PREP STATION FRONT PANEL 132X6 LEFT	
PS8	4	PREP STATION ANGLE PANEL ASSEMBLY	
PS1	2	PREP STATION 14' MID CROSS PANEL 120 X 20_16G	
P13	5	WP84X24.	
P109	2	WP120X24_20GA	
P332	6	SIDE DOWN DRAFT WP108X36_36" BAFFLE	
P333	6	SIDE DOWN DRAFT FILTER BAFFLE FOR 36 X 36_REV 4	
P128	2	WP108X18	
P334	2	SIDE DOWN DRAFT END PANEL 42" X 18"	
P16	2	SDDWP108X24_REV2	
P335	2	SDDWP108X18	
P19	1	SIDE DOWN DRAFT FILTER BOX 108 TOP PANEL	
P77	1	SIDE DOWN DRAFT FILTER BOX 108 X 20 TOP VENT PANEL RIGHT	
P130	2	SIDE DOWN DRAFT VENT PANEL 36 X90	
P131	2	SIDE DOWN DRAFT VENT PANEL 16 X90	
P208	2	WP108X36	
P21	1	SIDE DOWN DRAFT FILTER BOX TOP PANEL CONNECTOR PLATE 15.75 X 4 X .500	
IF2	4	INTAKE FILTER SHEET HOUSING 120 X 48	
IF6	4	INTAKE FILTER BLANKET GRID 107.500 X 35.750	
D30	1	RECT 36 X 14 ID TO 30 DIA	
R30	1	RING 30" DUCT	
FN30	1	FAN 30	
H7	12	SierraPacific-1190 - INTAKE HOUSING SUPPORT LATCH	

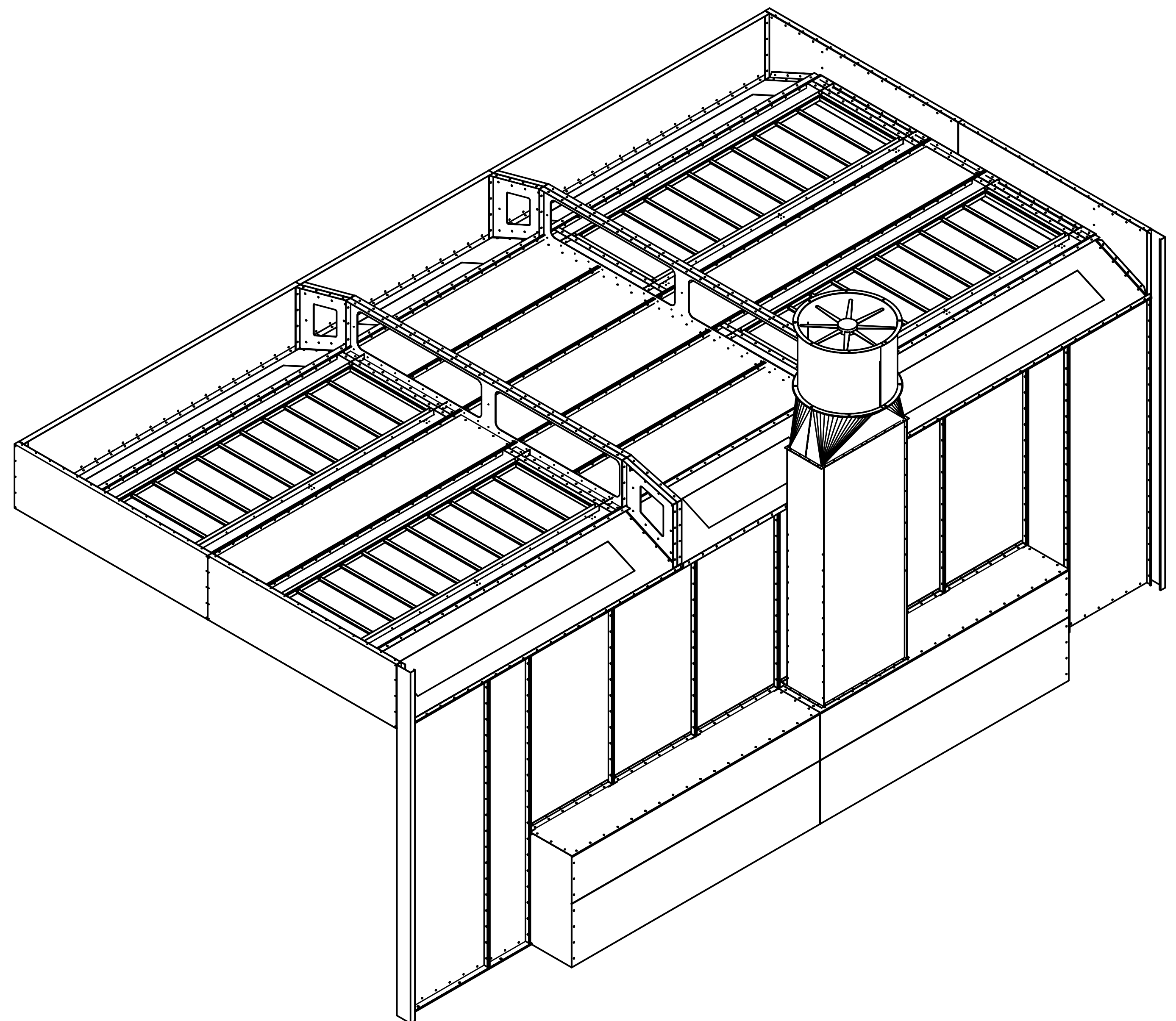

DRAWN Curtis K	6/21/2023	RGI SPRAY BOOTHS	
CHECKED		TITLE	
QA		DELTA PREP STATION	
MFG		27'L X 14'W X 9'H	
APPROVED		PART #	DWG NO
		SCALE	REV
		1 / 25	DELTA PREP STATION 14W X 27L X 9H
		SHEET	OF
		3	6

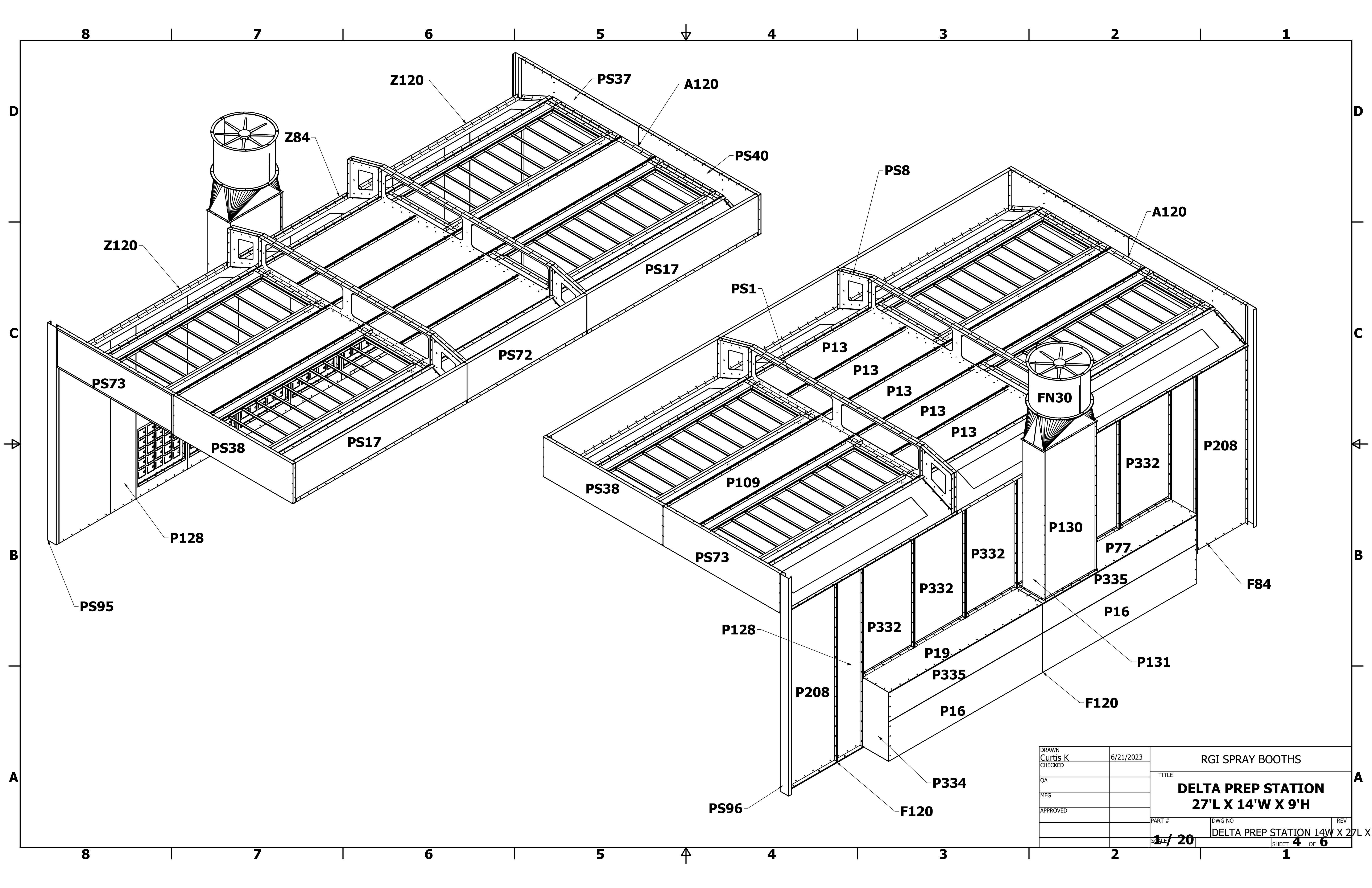

8 7 6 5 4 3 2 1

D

D

C

C

B

B

A

A

8 7 6 5 4 3 2 1

DRAWN Curtis K	6/21/2023	RGI SPRAY BOOTHS	
CHECKED		TITLE	
QA		DELTA PREP STATION	
MFG		27'L X 14'W X 9'H	
APPROVED		PART #	DWG NO
		SCALE	DELTA PREP STATION 14W X 27L X 9H
		SHEET	4 OF 6

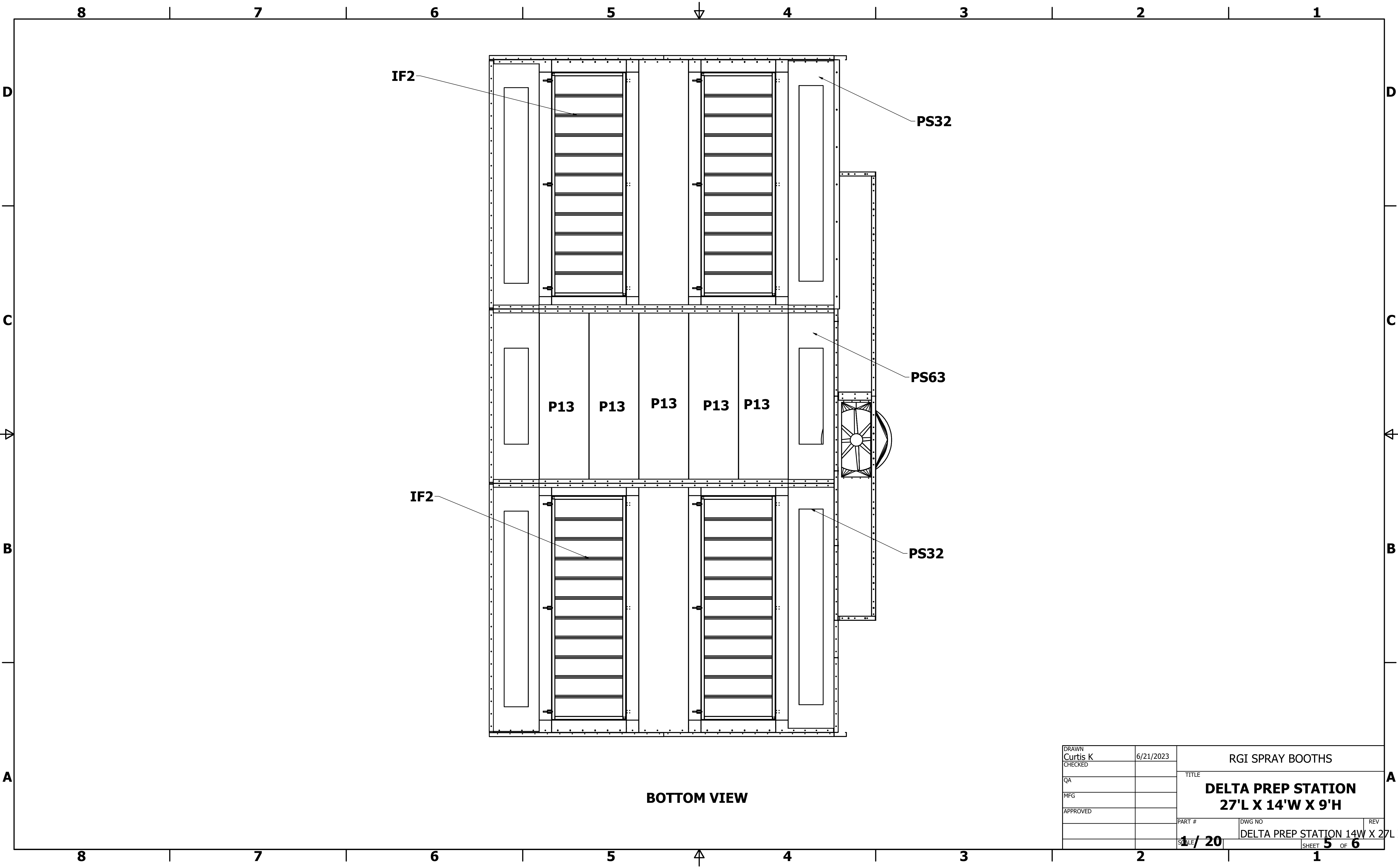

BOTTOM VIEW

DRAWN Curtis K	6/21/2023	RGI SPRAY BOOTHS	
CHECKED		TITLE	
QA		DELTA PREP STATION	
MFG		27'L X 14'W X 9'H	
APPROVED		PART #	DWG NO
		SCALE	DELTA PREP STATION 14W X 27L X 9H
		SHEET	REV
		5	6

8 7 6 5 4 3 2 1

D

D

C

C

B

B

A

A

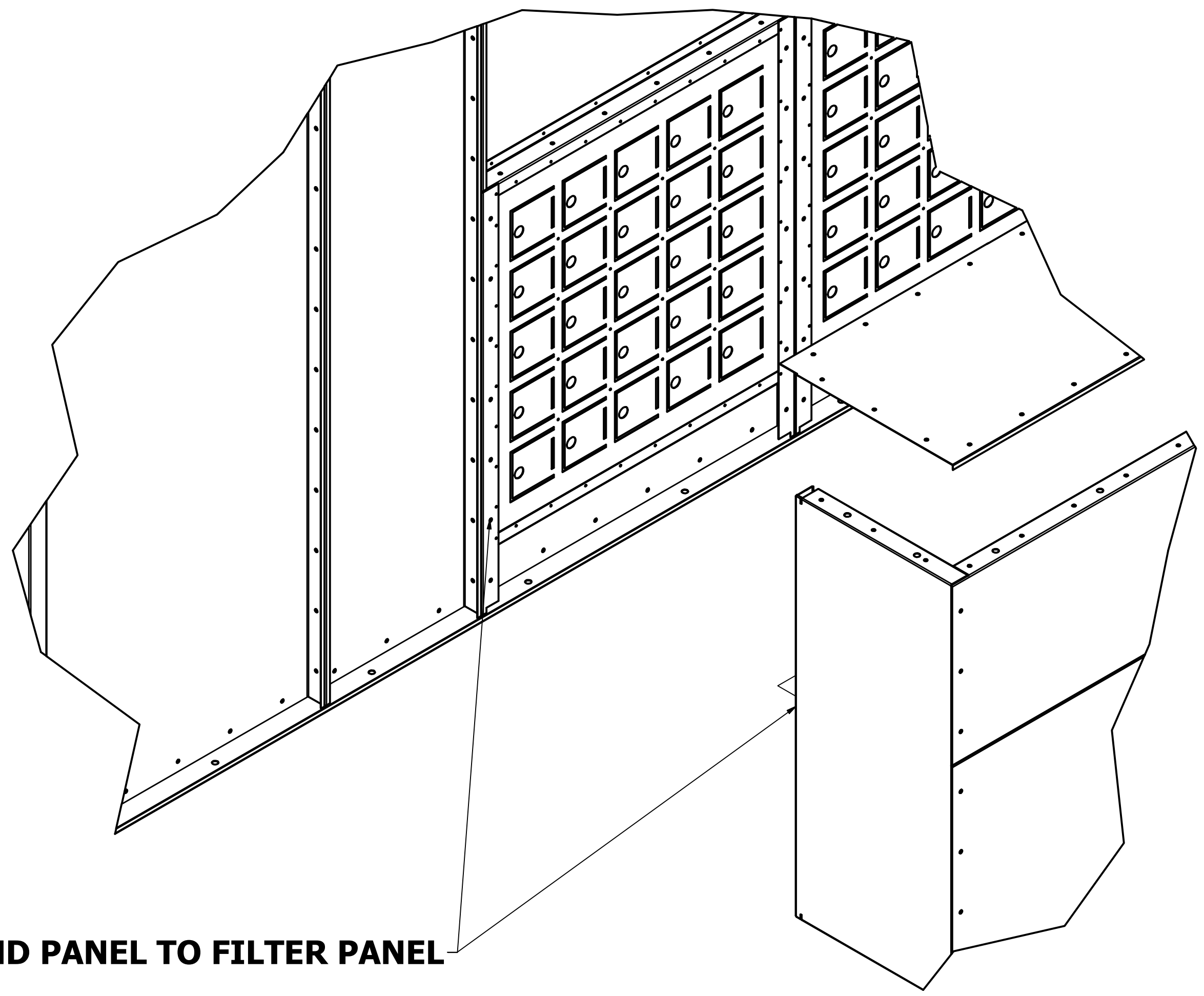
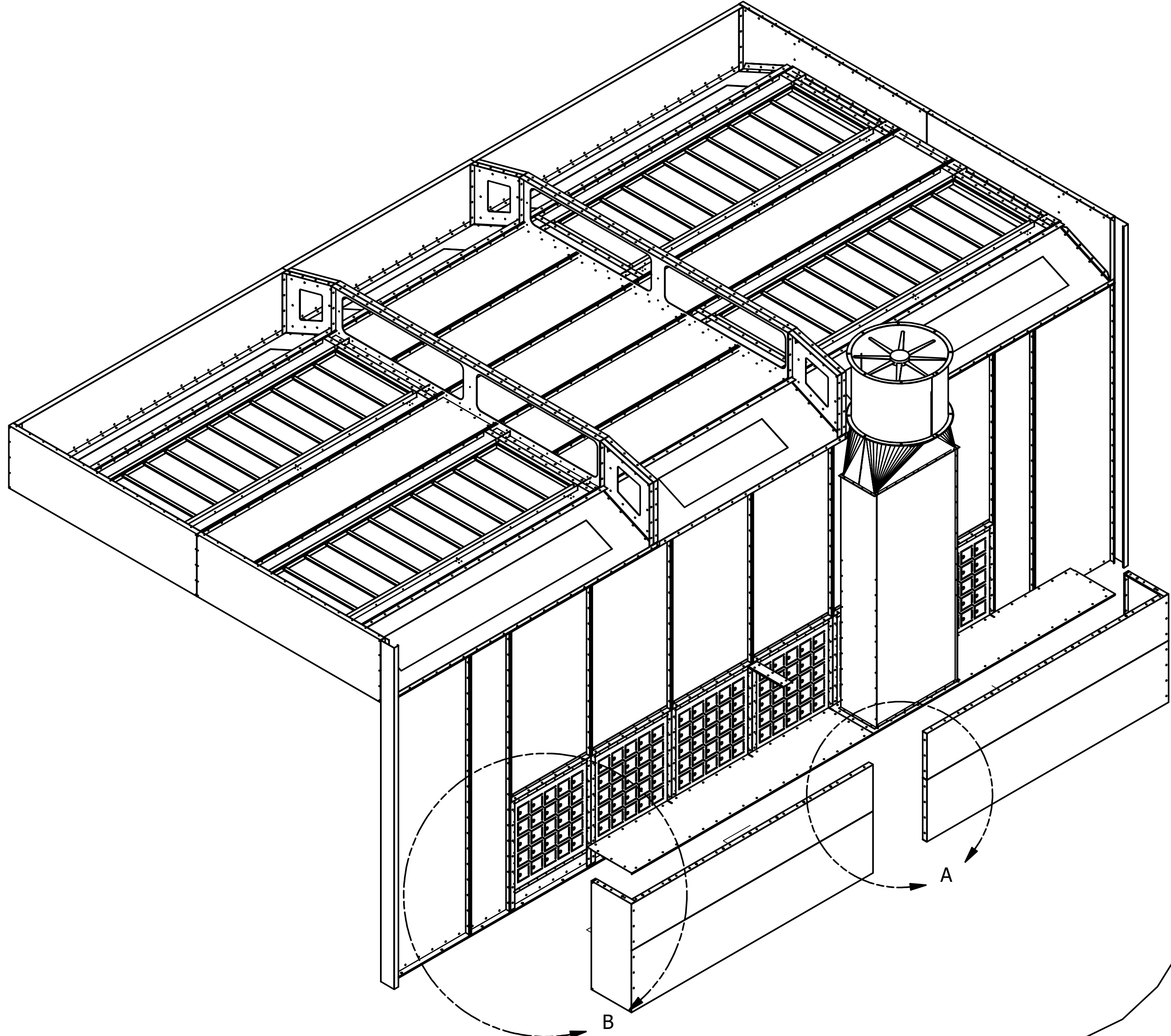

BOLT END PANEL TO FILTER PANEL

DETAIL B
SCALE 1 : 8

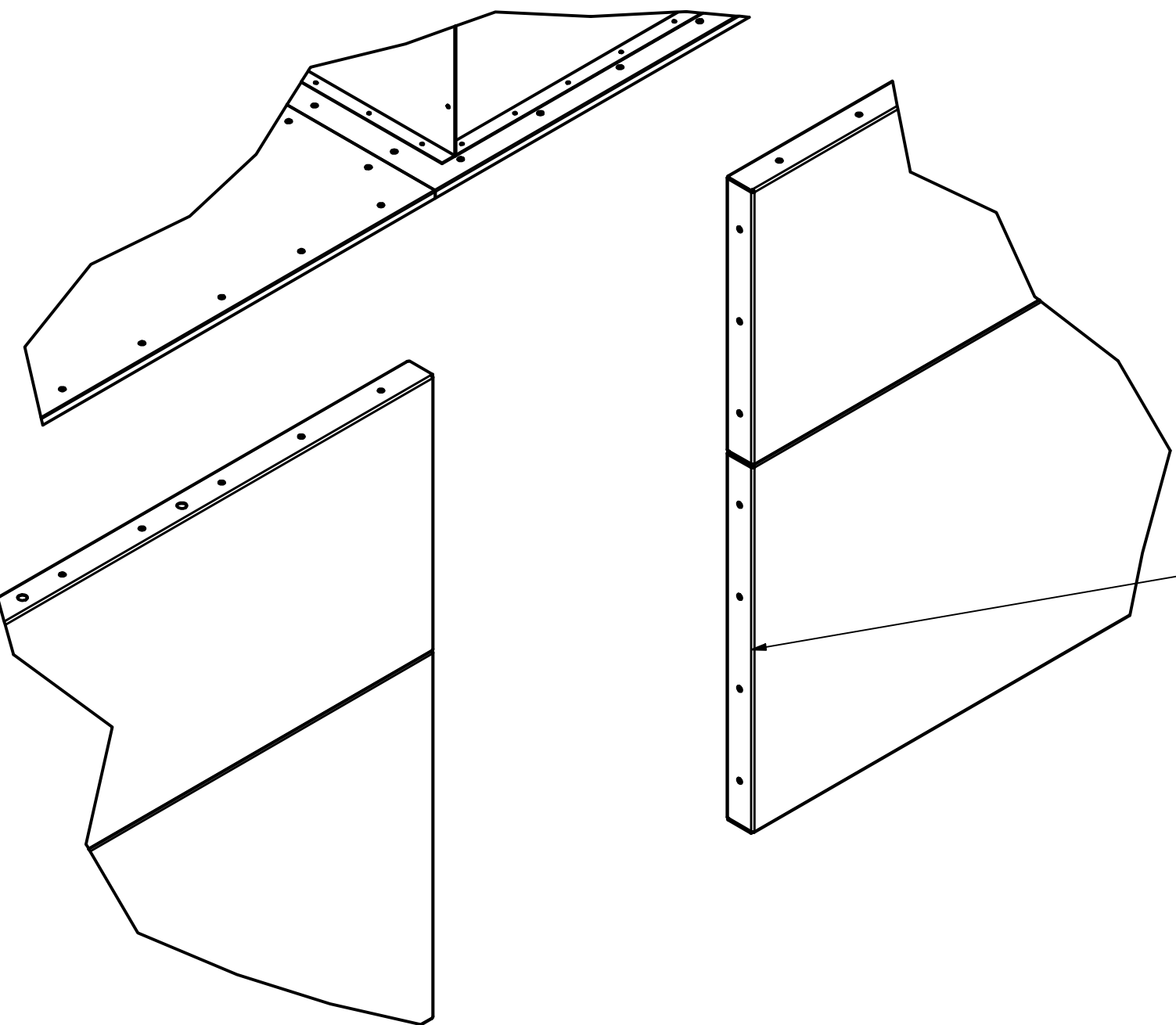

BOLT PANELS TOGETHER

DETAIL A
SCALE 1 : 8

DRAWN Curtis K	6/21/2023	RGI SPRAY BOOTHS	
CHECKED		TITLE	
QA		DELTA PREP STATION	
MFG		27'L X 14'W X 9'H	
APPROVED		PART #	DWG NO
		SCALE	REV
		1 / 25	DELTA PREP STATION 14W X 27L X 9H
		SHEET	6 OF 6

8 7 6 5 4 3 2 1

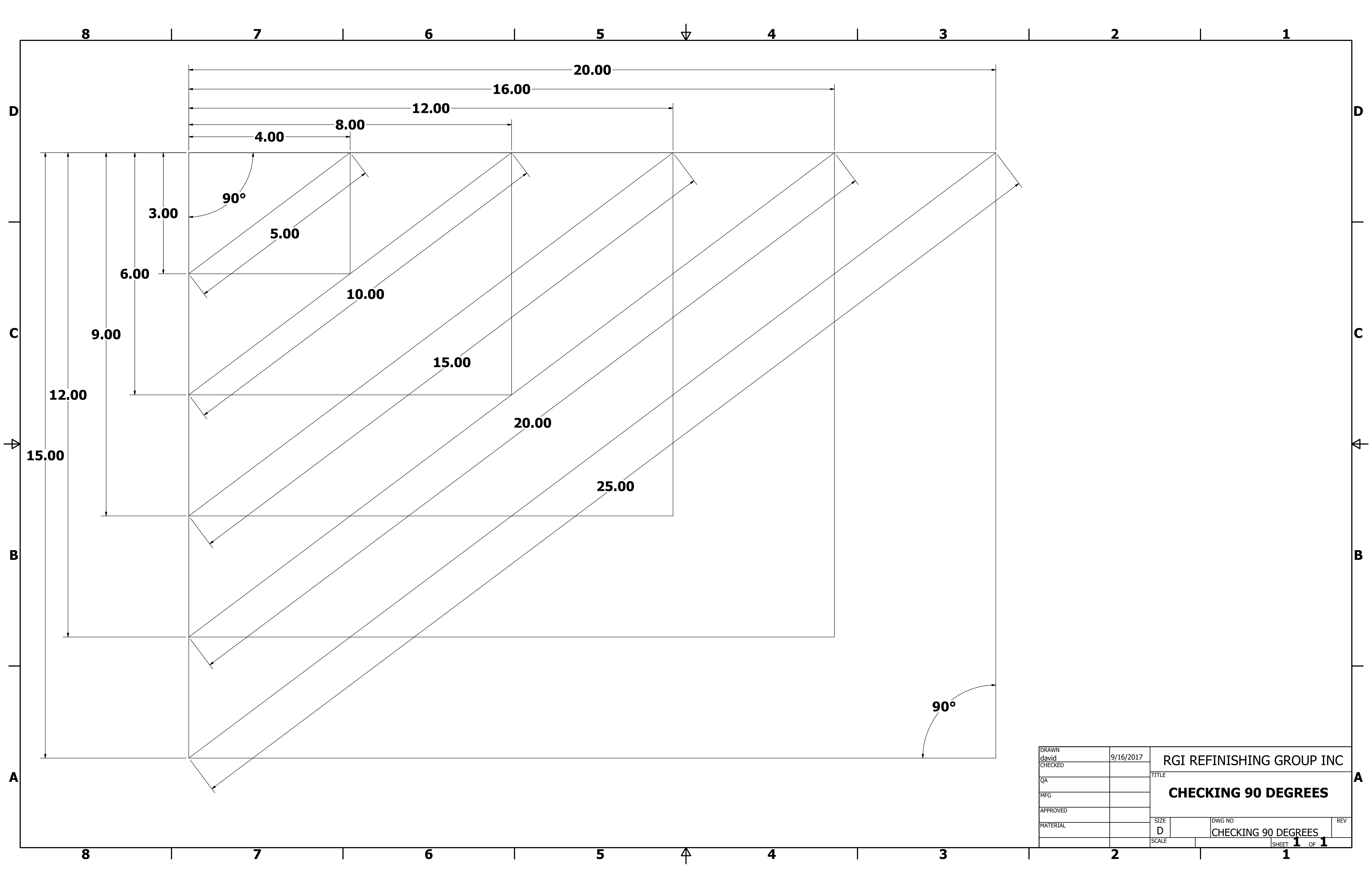

DRAWN	david	9/16/2017	RGI REFINISHING GROUP INC		
CHECKED			TITLE		
QA			CHECKING 90 DEGREES		
MFG			SIZE	DWG NO	REV
APPROVED			D	CHECKING 90 DEGREES	
MATERIAL			SCALE	SHEET 1 OF 1	

1/4-20 X 0.750 BOLT & NUT TYPICAL

**USE SELF TAPPING SCREWS WHERE
NO MATING 0.312 HOLE EXISTS.**

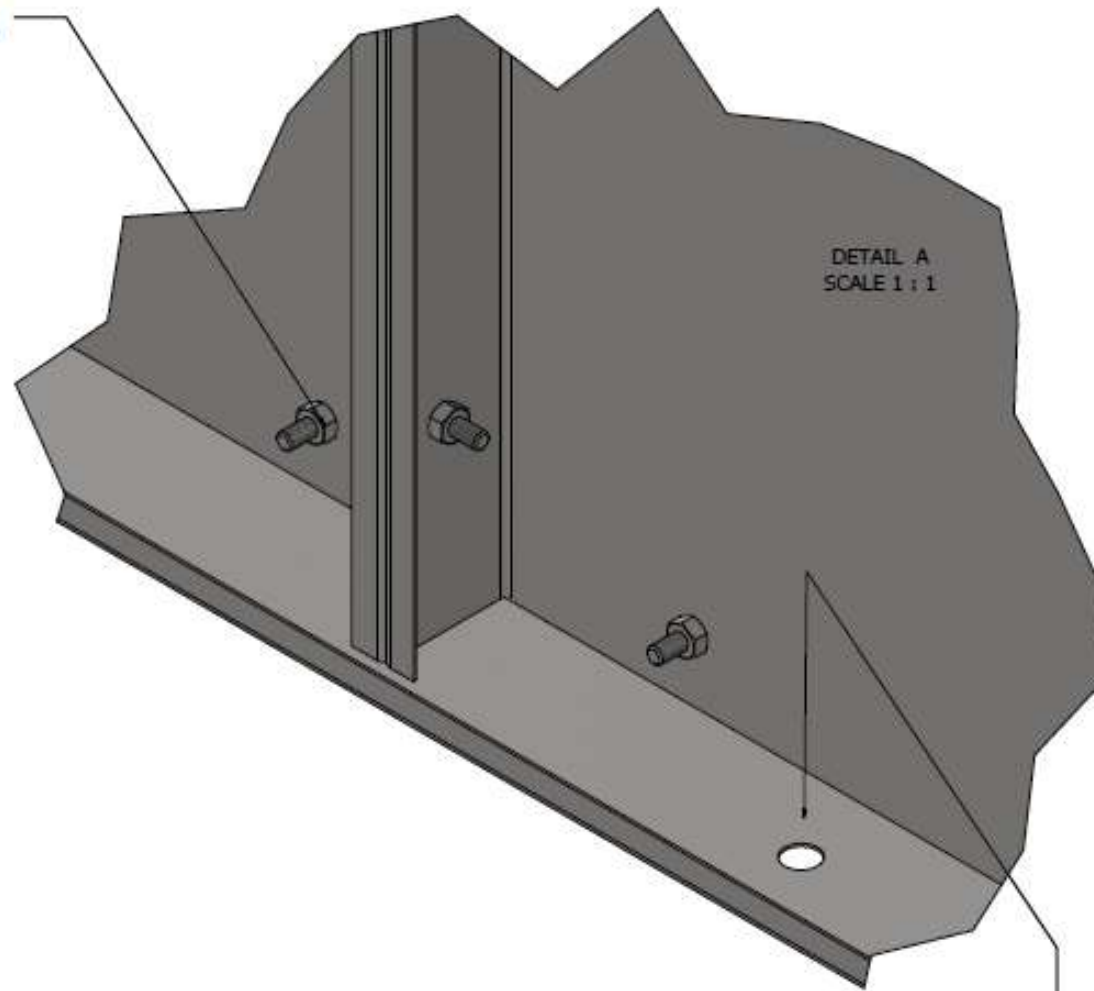

CONCRETE ANCHOR

DRAWN	4/28/2018	RGI SPRAY BOOTHS	
CHECKED		TITLE	
QA		TYPICAL SPRAY BOOTH ASSEMBLY	
MFG		SIZE	DWG NO
APPROVED		D	VECTOR 27 DUAL INTAKE FILTER 1
MATERIAL		SCALE	1 / 16
			SHEET 1 OF 1

8 7 6 5 4 3 2 1

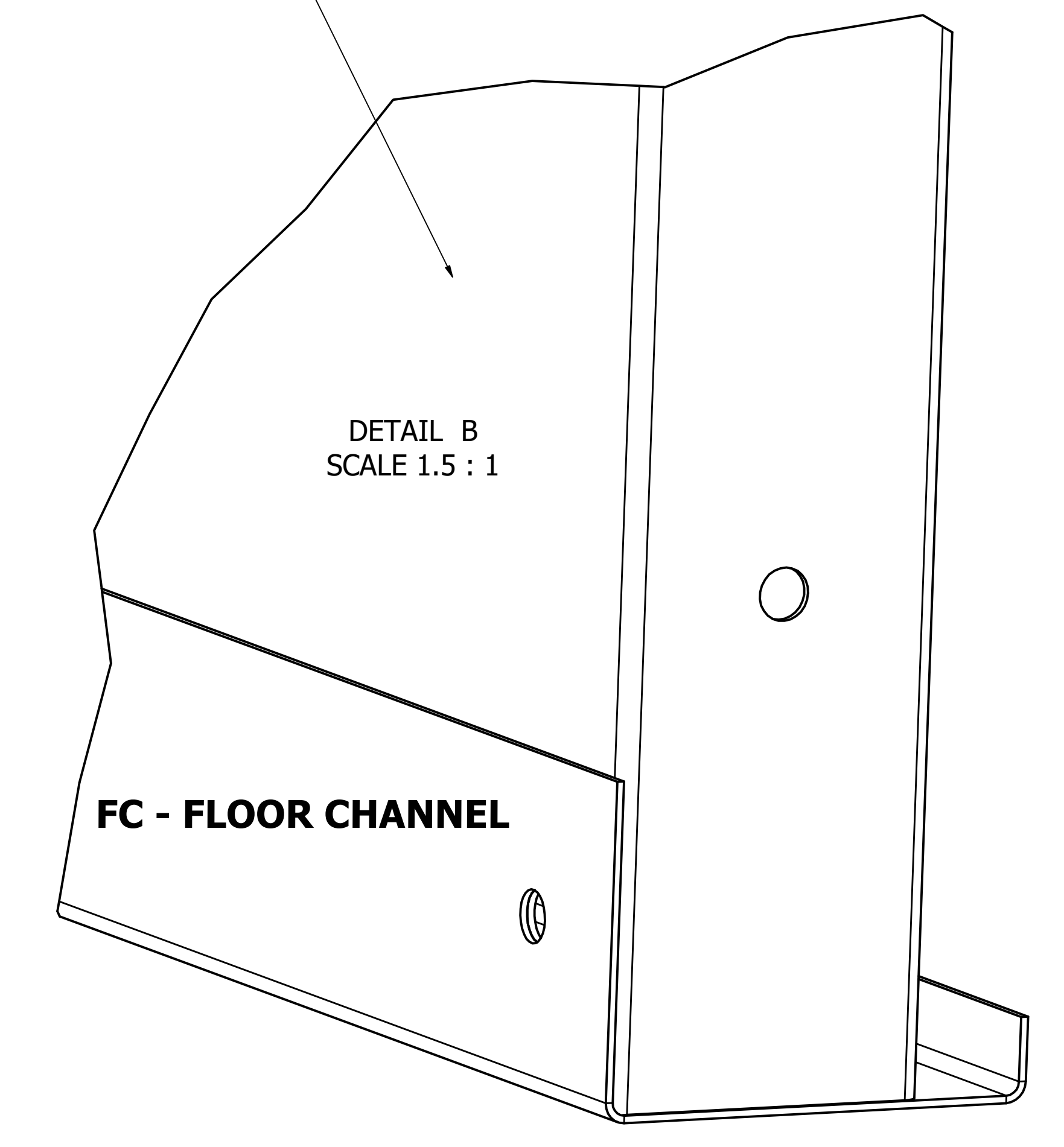
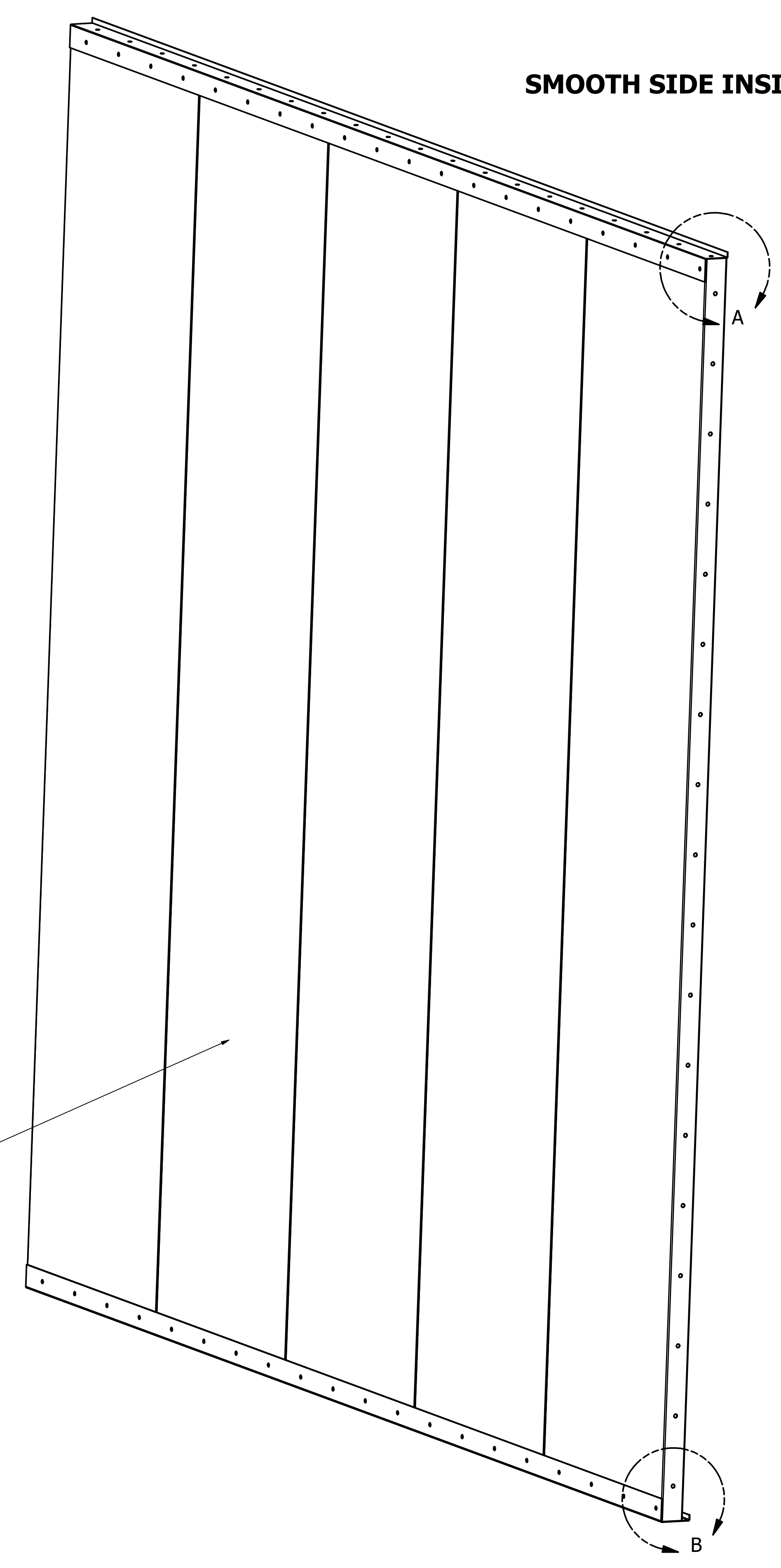
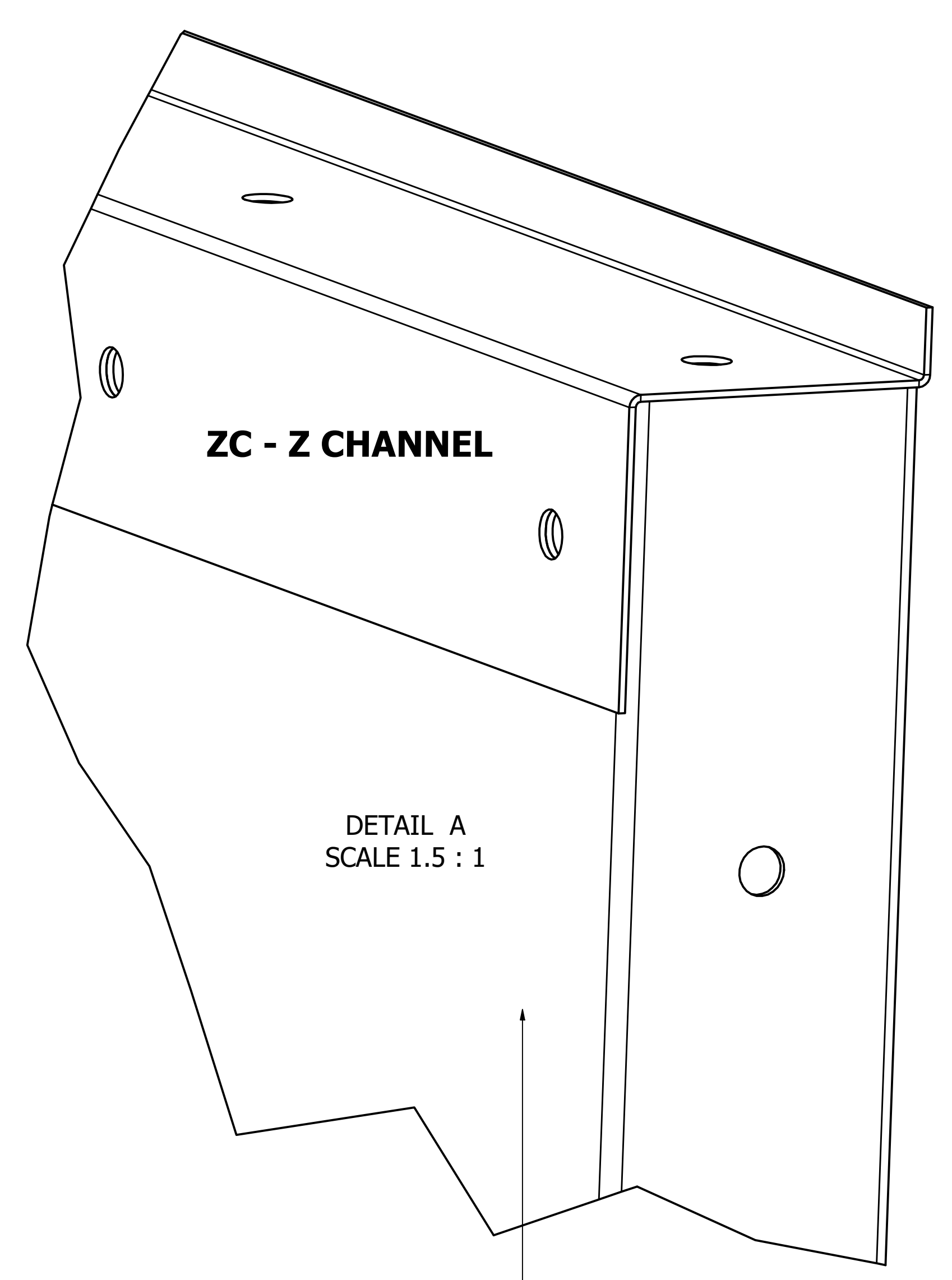

THIS DOCUMENT CONTAINS CONFIDENTIAL AND PROPRIETARY INFORMATION THAT CANNOT BE REPRODUCED OR DIVULGED, IN WHOLE OR IN PART, WITHOUT WRITTEN AUTHORIZATION FROM RGI SPRAY BOOTHS

DRAWN david	10/28/2021	RGI SPRAY BOOTHS	
CHECKED		TITLE ZC - Z CHANNEL FC - FLOOR CHANNEL ASSEMBLY	
QA		SIZE D	DWG NO ZC & FC ASSEMBLY EXAMPLE
MFG		SCALE .15	REV
APPROVED		SHEET 1 OF 1	
MATERIAL			

8 7 6 5 4 3 2 1

THE BRACKETS ARE STOCK FROM THE CURTAIN MFR. WE DON'T USE THEM. YOU NEED TO DRILL HOLES IN THE TRACK AND MOUNT AS SHOWN USING SELF TAPPING SCREWS.

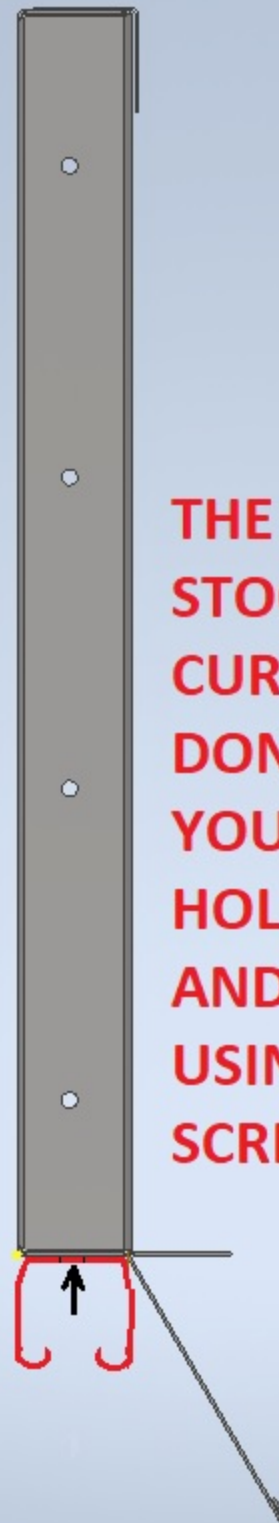

8 7 6 5 4 3 2 1

PARTS LIST			
ITEM	QTY	PART NUMBER	EXTRA QTY
D1	2	DUCT 48" LONG 20GA	
FN1	1	FAN	
R1	1	RING 2" HEIGHT	
D2	1	DUCT INSPECTION 48" LONG 20GA	
D3	1	DUCT INSPECTION COVER 20GA	
D4	4	DUCT QUARTER SECTION SKIRT (COLLAR) 20GA	
D5	1	DUCT FLASHING DUCT DIAMETER + 6" 20GA 15" HEIGHT	
D6	1	DUCT DAMPER ASSEMBLY	

- NOTES:
- 1) MALE (CRIMPED END) OF DUCT MUST BE UP & FEMALE END IS DOWN
 - 2) FIRE WRAP IS USED ON WOODEN ROOFS
 - 3) ALLOW 2" FOR EACH CONNECTION

DETAIL B
SCALE 1 / 7

DRAWN	david	2/12/2021	RGI SPRAY BOOTHS	
CHECKED			TITLE	
QA			DUCTING KIT	
MFG			SIZE	DWG NO
APPROVED			D	FAN & DUCT KIT
MATERIAL			SCALE	REV
			1 / 14	SHEET 1 OF 1

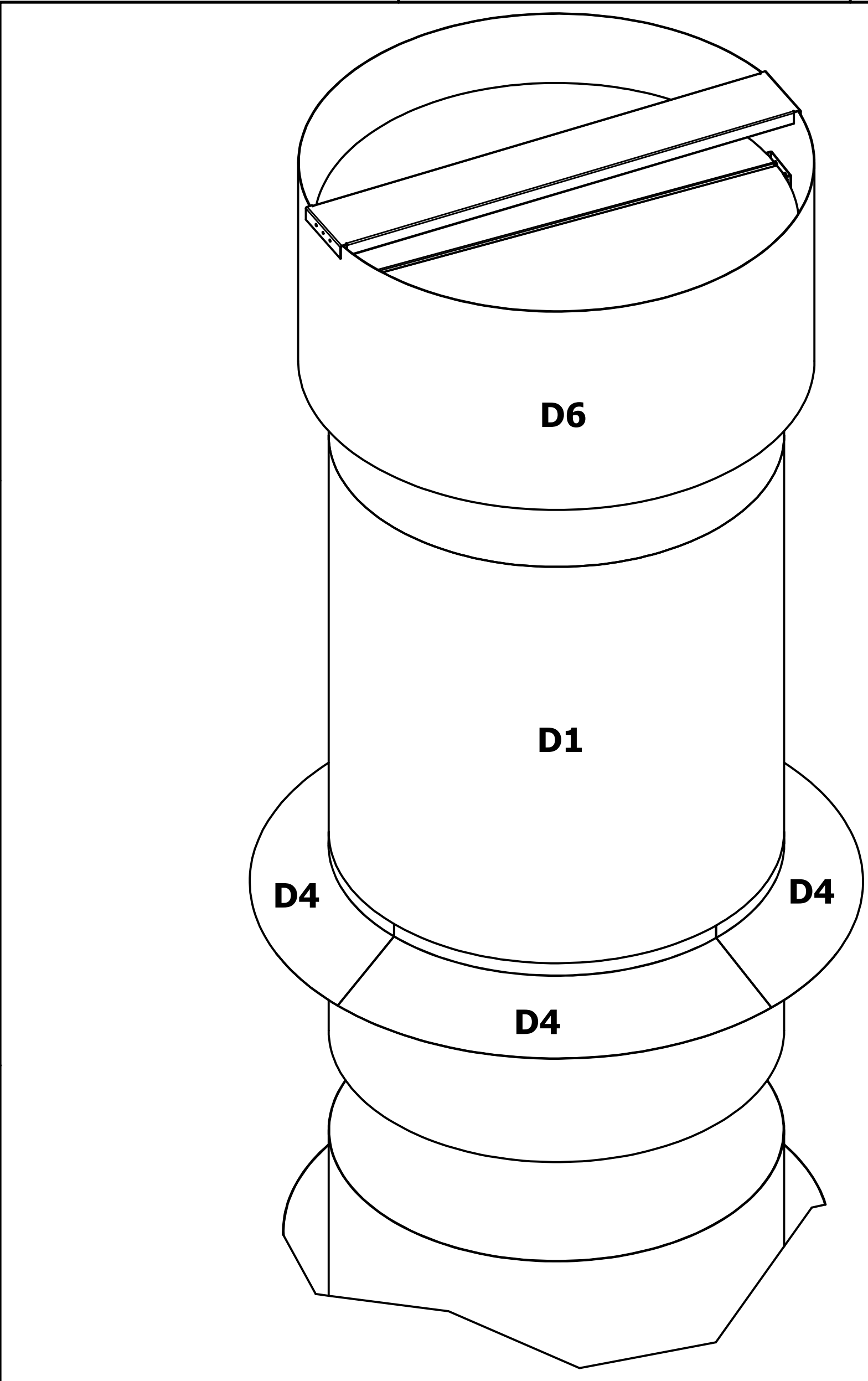

DETAIL A
SCALE 1 / 7

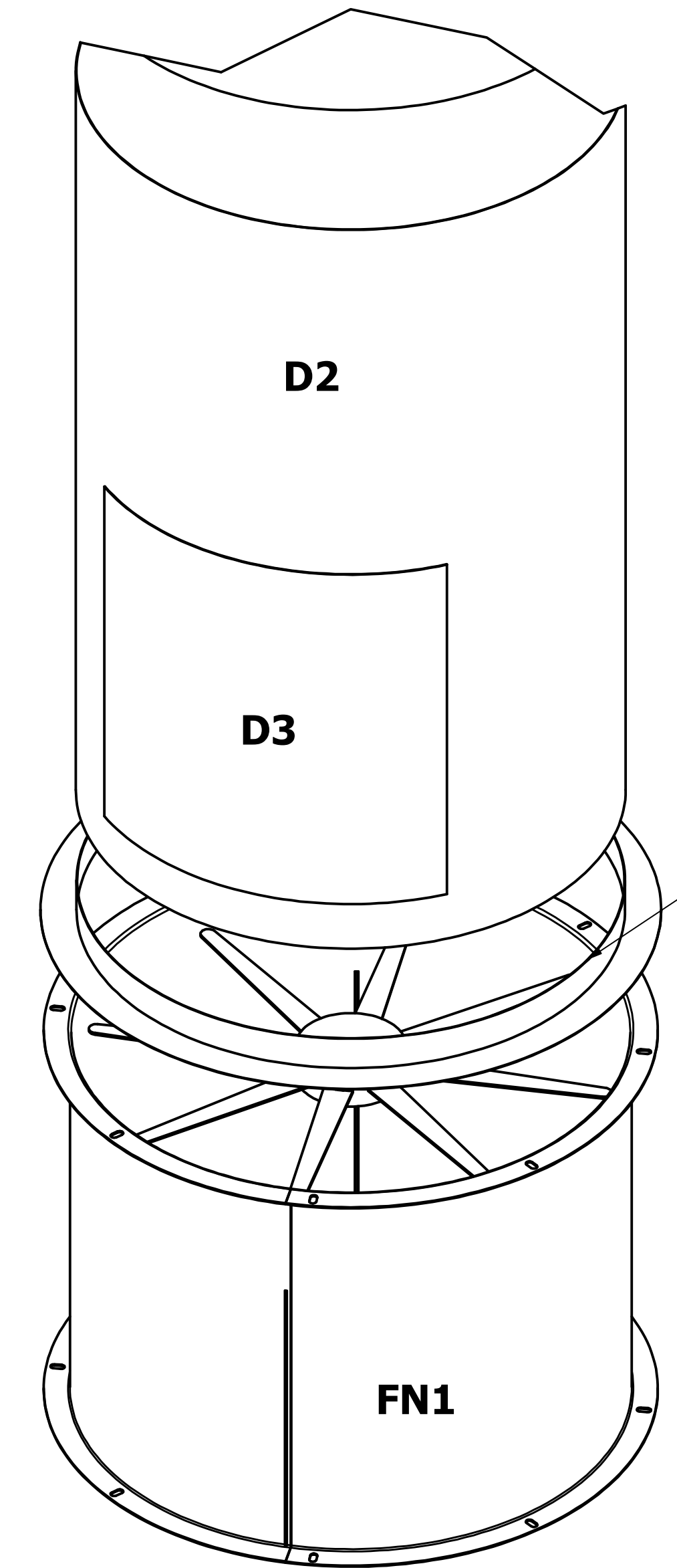
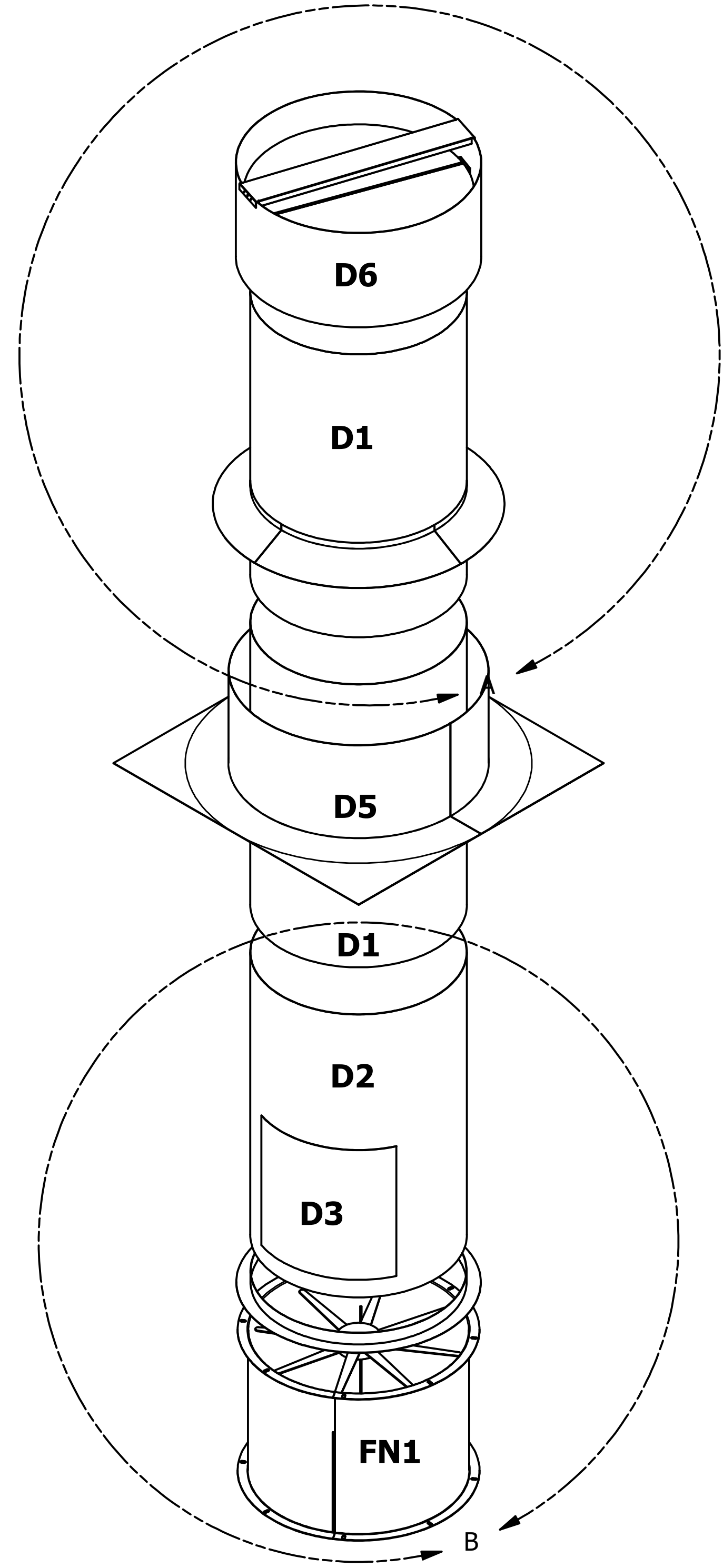

THIS DOCUMENT CONTAINS CONFIDENTIAL AND PROPRIETARY INFORMATION THAT CANNOT BE REPRODUCED OR DIVULGED, IN WHOLE OR IN PART, WITHOUT WRITTEN AUTHORIZATION FROM RGI REFINISHING GROUP INC

8 7 6 5 4 3 2 1