

# Model No. SAE-UT10000

## Installation & Operation & Maintenance Instructions

**Full Rise Ultra Thin**

**Scissor Lift**

**Lifting Capacity 10000 lbs**



### Important Note

1. This equipment can not be installed, operated or repaired without reading instructions.
2. Electricity must be hooked up by certified electrician.
3. Do not use this equipment beyond its rated capacity.

## **Contents**

Chapter 1 Safety Precautions. . . . .	4
Chapter 2 Product and Parameters. . . . .	5
Chapter 3 Preparation for Installation. . . . .	9
Chapter 4 Commissioning. . . . .	18
Chapter 5 Maintenance. . . . .	20
Chapter 6 Exploded views. . . . .	24

## Chapter 1 Safety Precautions

1. Make sure that you have read the User' s Manual completely including relevant instructions on installation, operation and safety before operating the lift.
2. Do not use the lift if any abnormality is found in the lift.
3. Do not overload the lift beyond its rated load 3000KG.
4. The lift can be operated by trained personnel only. The vehicle customer or the inexperienced person is prohibited from operating the lift at will.
5. The rubber pad of the small scissor lift must have contact with the support point of the vehicle, otherwise the vehicle chassis may be damaged. (It is recommended to consult the vehicle manufacturer by telephone if the location of the support point is not clear.)
6. Be sure to perform mechanical locking after the vehicle is lifted. It is forbidden to work under the vehicle before mechanical locking is performed.
7. Keep the area around the lift clean and tidy as any oil stain or obstacle may pose a safety risk.
8. Never lift the vehicle with people in it.
9. Make sure there is no obstacle under the vehicle before lowering it.
10. It is prohibited to remove any hydraulic component when the hydraulic system is under pressure.
11. Do not put hands at any dangerous place, such as the space between tool arms.
12. It is prohibited to use the product outdoors as it is only suitable for indoor use.
13. Press and hold the Down button while lowering, so the platforms ascend a little automatically to open the safety lock, and then descend automatically.
14. Always wear safety shoes during operation.
15. It is forbidden to lift the vehicle when someone is in the vehicle.
16. Cut off the power supply after the use of lift.
17. When a vehicle is being loaded onto or unloaded from the lift, no person is allowed to stand in the vehicle passage.
18. Ensure that the platforms of main and sub lifts are lowered to the lowest positions before the vehicle departs from/leaves the lift.
19. Use wedge blocks to lock the vehicle so that the vehicle cannot move.
20. Read the operation warning label carefully and thoroughly

## Chapter 2 Product Features and Parameters

### 2.1 Product features

Movable ramp which can be used as extension board

Monolithic base-plate without splice

Stable and reliable control system

Aluminum alloy motor with low noise and fast heat dissipation

### 2.2 Technical parameters

Rated lifting capacity		10000LBS (4500KG)
Initial height		4 5/16"(110mm)
Lifting height		72 1/16" (1830mm)
Platform length		60 1/4"(1530-2140mm)
Platform width		26 3/16" (665mm)
Motor parameters	<b>SAE-UT10000</b>	1PH,220VAC,3KW
Type of hydraulic oil		ISO 46#
Air pressure		0.6-0.8MPa



Diagram of product:

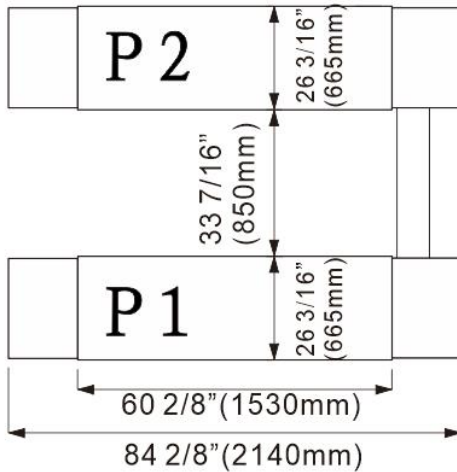
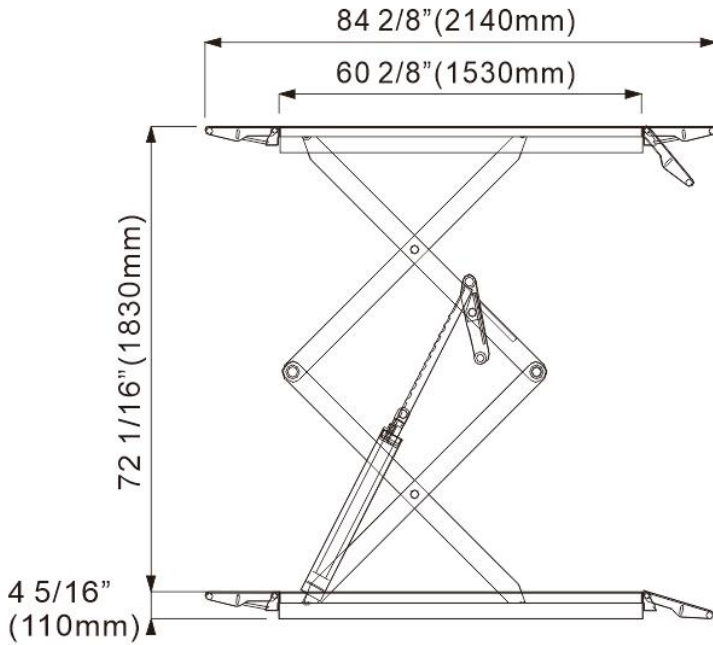

Electrical diagram

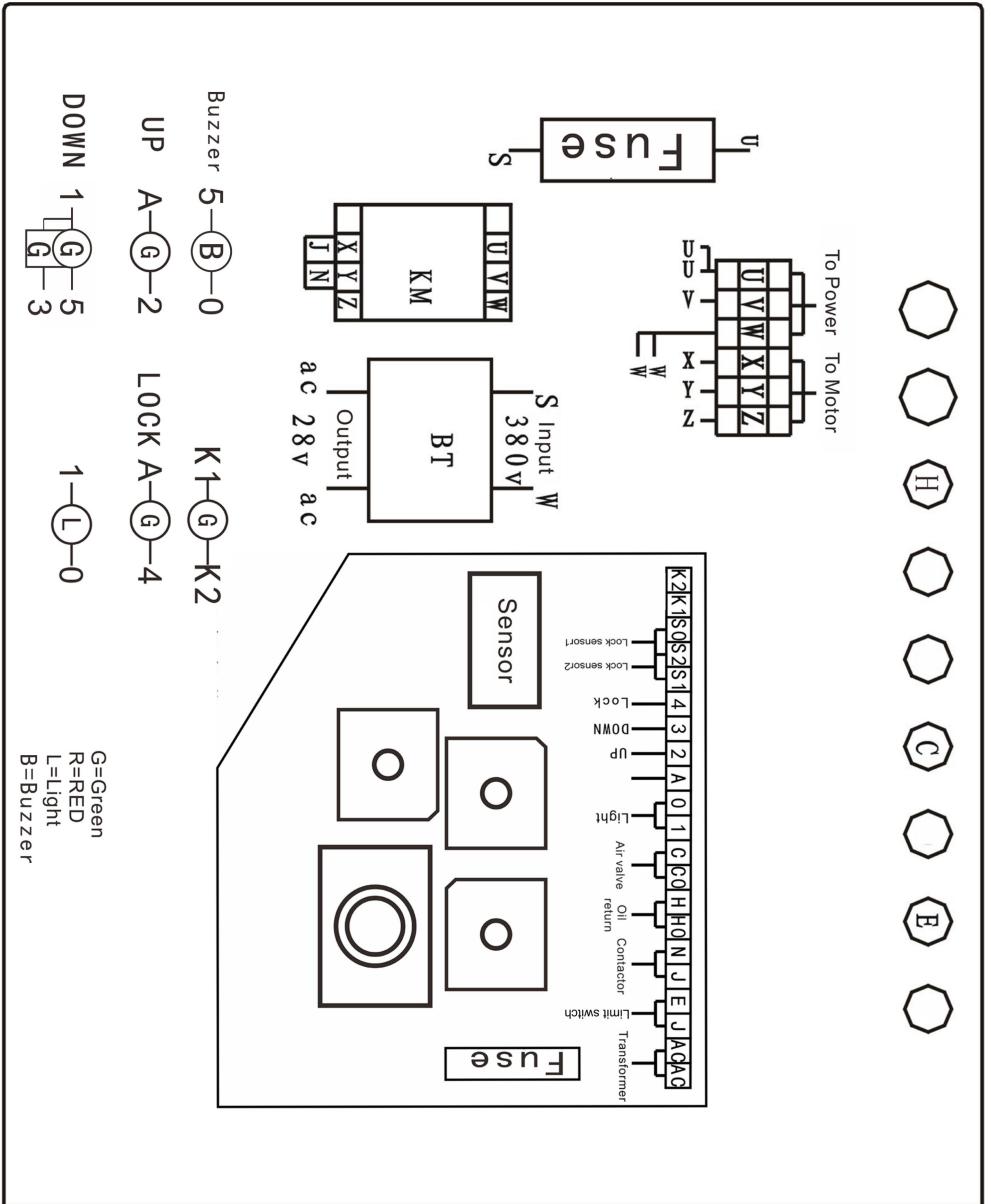

### **2.3 Schematic diagram for main components**

Working platform: For lifting the vehicle by contacting the chassis.

Safety gear rack: Safety mechanism for mechanical locking.

Gear block: Blocking safety gear rack.

Ramp: Can be pulled up and used as extension board to bear load.

Auxiliary arm: Providing help at the start of lowering and raising.

Control cabinet: Control unit, providing the power takeoff.

Master cylinder: Actuator, pushing the platform to rise, with two oil pipes.

Slave cylinder: Actuator, pushing the platform to rise, with one oil pipe.

Scissor arm: Main lifting structure.

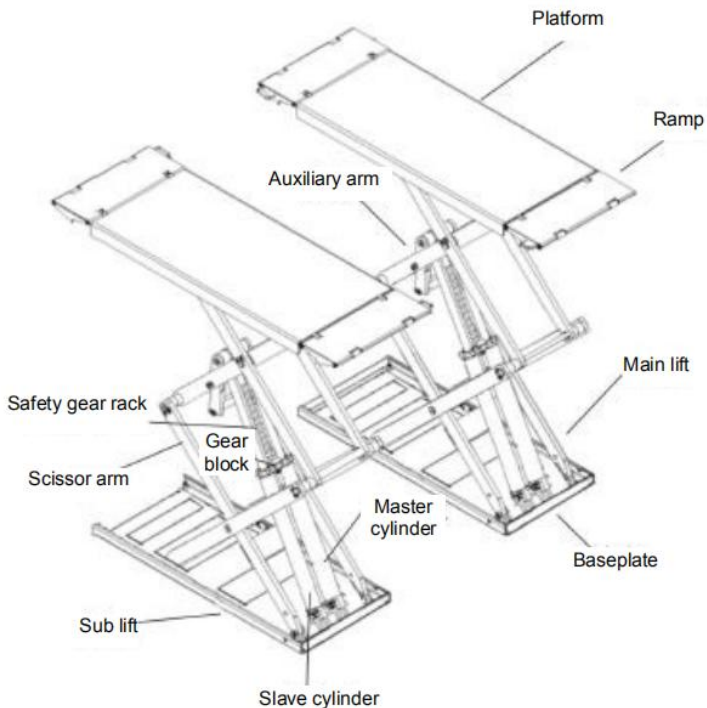



## Chapter 3 Preparation for Installation

### 3.1 Unpacking

All packing, loading/unloading, transportation and unpacking operations must be performed by professional personnel.

Transportation:

The scissor lift shall be loaded/unloaded and moved by a lifting machine and forklift with capacity over 3 tons. To prevent the scissor lift falling off, one person shall pay attention to the scissor lift during the lifting operation for fear of accidents. The scissor lift shall be transported by an automobile or ship.

The scissor lift shall be inspected for completeness when it arrives, for fear of damage or loss during transportation.

If the packing box is broken during transportation, inspect the broken box according to the Packing List, confirm the damaged articles and lost components, and at the same time, inform the carrier immediately.

The lift is heavy! Therefore, manpower loading/unloading and handling are forbidden. Safety is of much importance. In addition, the hoisting of scissor lift during loading/unloading shall be operated as illustrated.

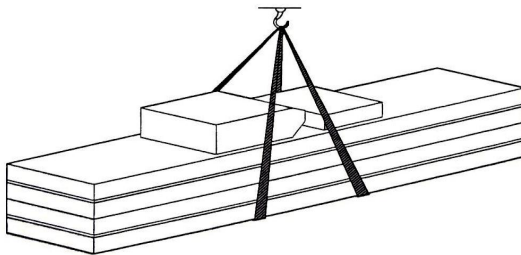

### Storage:

Machinery equipment shall be stored in an indoor warehouse, and waterproof treatment shall be adopted in case of outdoor storage. A van truck shall be used for highway transportation, and a container for waterway transport. The control cabinet must be placed upright during transportation, and be protected from squeezing by other goods.

### 3.1 Preparation for installation

#### Installation scheme

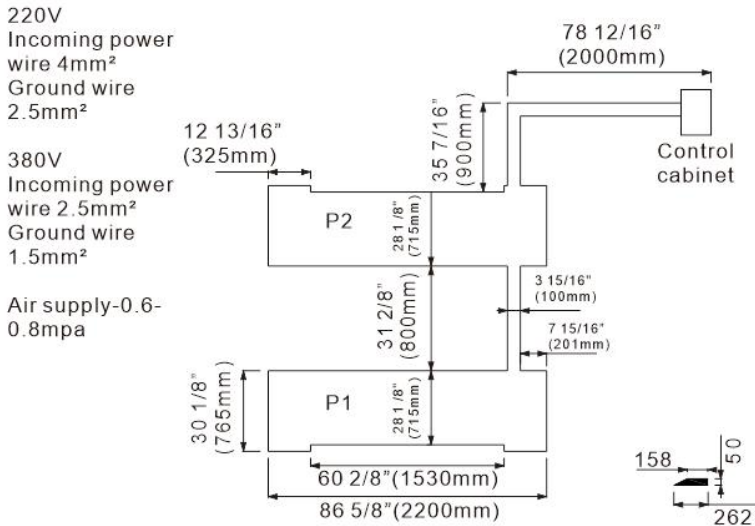

Note

1. The foundation pits shall be 125mm deep with flat surfaces, unevenness no greater than 1.5mm, vertical walls, and upper edges covered with 40\*40 angle steel.
2. The concrete shall be reinforced with steel bars, and have a thickness greater than 250mm and a compressive strength no lower than 25MPa. The grade of the foundation concrete shall be greater than C25.
3. Φ120mm PVC pipe shall be buried 125mm deep between the two places respectively for the distribution box of the station and the control cabinet of the lift.

Schematic diagram:

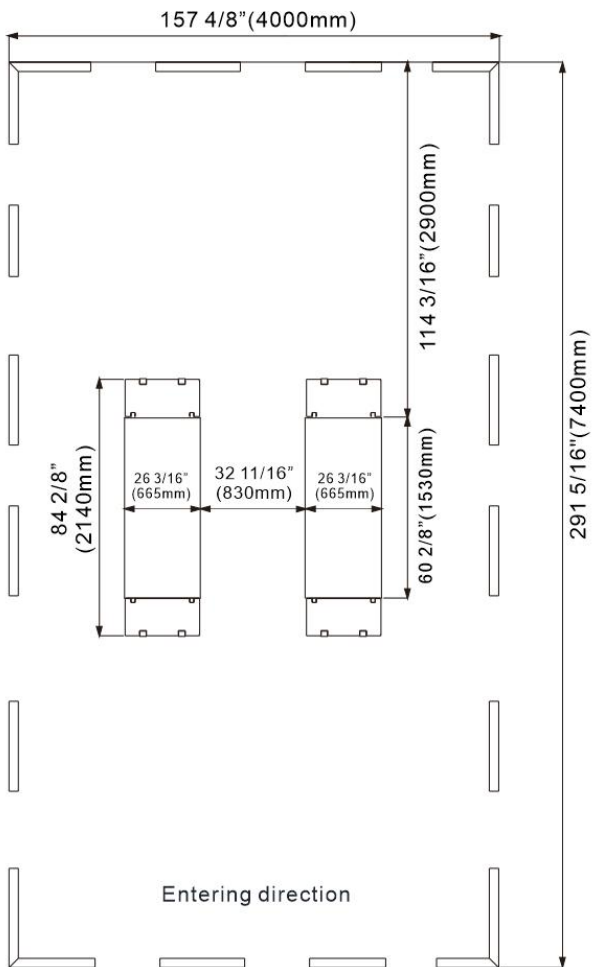

Voltage	Power	Start current	Operating current	Wire size	Air switch	Applicable to
220V	3KW	60A	21A-25A	≥4mm <sup>2</sup>	C63	Scissor lift
220V	2.2KW	60A	20A-22A	≥4mm <sup>2</sup>	C63	Two posts, four posts

**3.3 Installation:**



- Only professionals are allowed to conduct the installation work. Moreover, they shall read and follow the operation instructions below carefully to prevent machine damage or injuries.
- Only authorized technicians are allowed to install the lift.

**3.3.1 Installation requirements:**

The lift must be installed in accordance with the specified safe distances from walls, columns and other equipment (as shown in Fig. 8), including the minimum distance 2000mm-2900mm from walls.

The ceiling height cannot be less than 4000mm. It is recommend to install the lift in a pit, and construct the foundation as required in Fig. 8.

Nevertheless, the lift can be installed on any indoor floor, provided that the floor meets the leveling requirements and has enough bearing capacity ( $\cong 25\text{MPa}$ ).

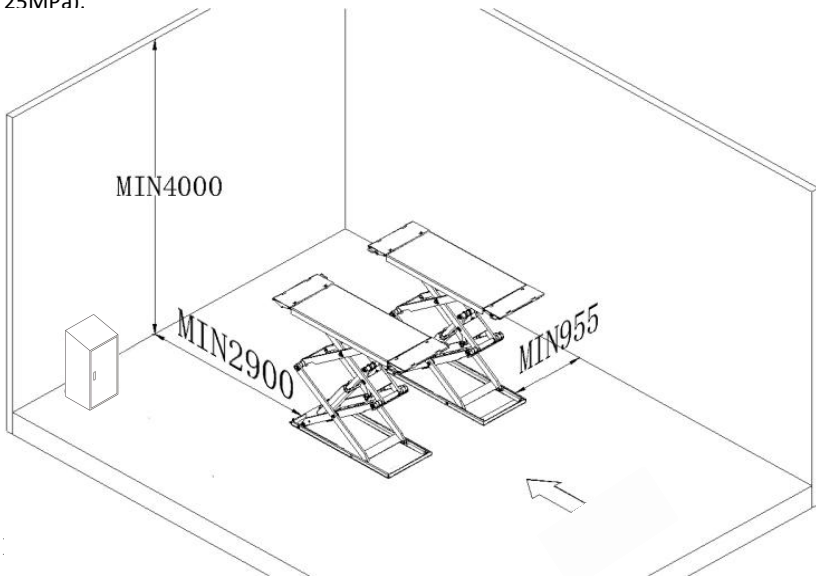

The arrived goods shall be inspected for completeness before installation of scissor lift.

The movement and installation of the lift shall be carried out by the professionals.

For the transportation and storage of the machine, refer to the “Transportation and Storage” on page 11.

### 3.3.2 Installation of lifting platforms

Determine the installation direction of the lift according to the arrows on the lift package. When the lift is installed in the pit or on the ground, insert adjusting sizing blocks under the platform, lift the lifting platform with a forklift or other lifting equipment (Fig. 9) to about 1000MM, so as to ensure that the mechanical safety device is activated and locked.

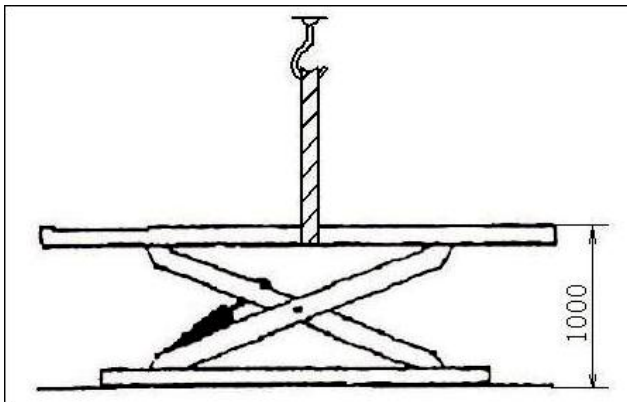

Fig. 9



- To avoid the failure of the mechanical safety device, a wood block can be inserted at the middle of the connecting rod. When the hydraulic system is not fully filled with hydraulic oil and has the lifting and lowering actions, do not work under the lift. Move the lifting platforms, adjust the distance between two platforms to make them parallel, and connect the electric circuit, oil circuit and pneumatic circuit as specified in the Electrical Diagram and Oil Circuit Connection Diagram.
- Only after the hydraulic system connection is completed, the pneumatic circuit connection can be conducted.
- Oil pipes, electric wires and air pipes shall not be damaged.



- Connection of electrical circuit: Connect the electrical circuit according to the wire diameter and wire size specified in the Electrical Diagram.



Only the professionals qualified for electrical operation are allowed to conduct the electrical installation

- Open the upper cover of the control cabinet first



- Connection of power line: Connect the 380V three-phase four-wire power line (cable of  $3 \times 2.5\text{MM}^2 + 1 \times 1.5\text{MM}^2$ ) to the control cabinet interfaces U, V, W and input terminal, and connect the PE grounding wire to the labeled grounding bolt firstly and then to the labeled grounding bolts at the bottom of the two platforms (Fig. 10, 11)

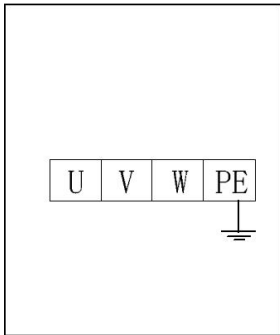

Fig. 10

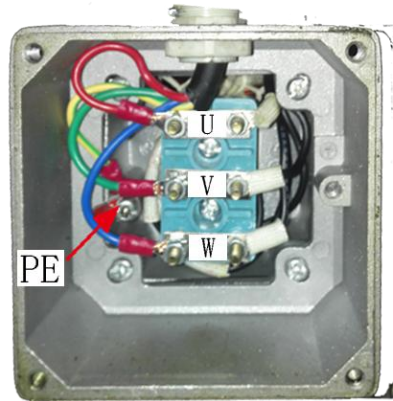
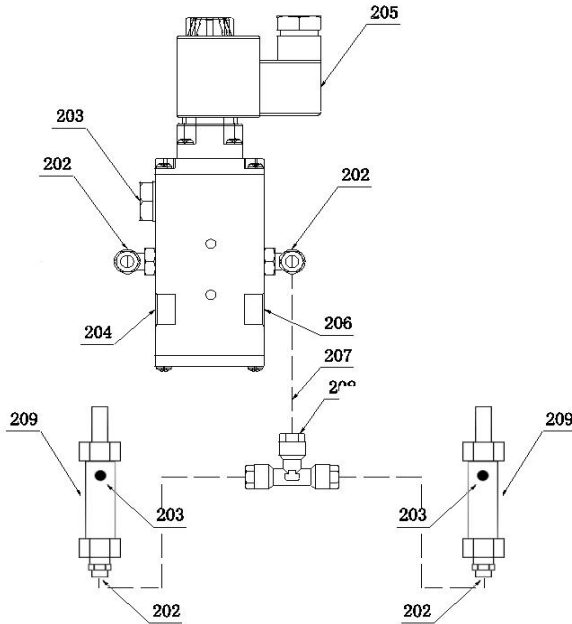

Fig. 11





Connection schematic diagram of air pipe joint:



S/N	Part No.	Quantity
203	Muffle	3
204	Plug 1/8	1
205	Solenoid valve	1
206	Plug 1/4	1
207	Air pipe PU0604	1
208	T-joint APE	1
209	Small cylinder	2
211	Air pipe PU0806	



Schematic diagram of oil pipe joint:

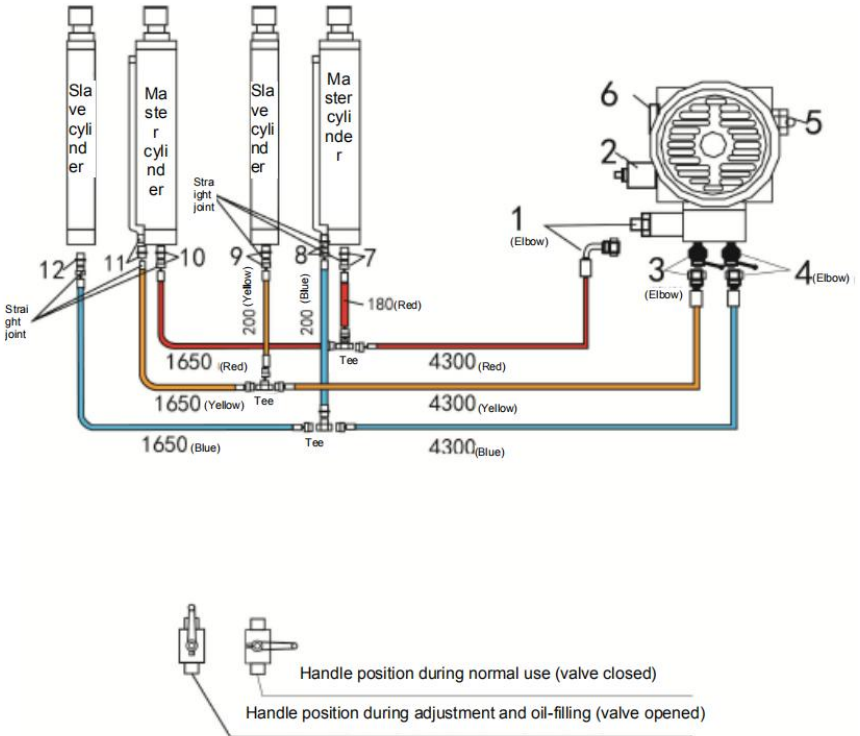

Note: Adjustment is only necessary in case of imbalance of both platforms



Hydraulic schematic diagram:

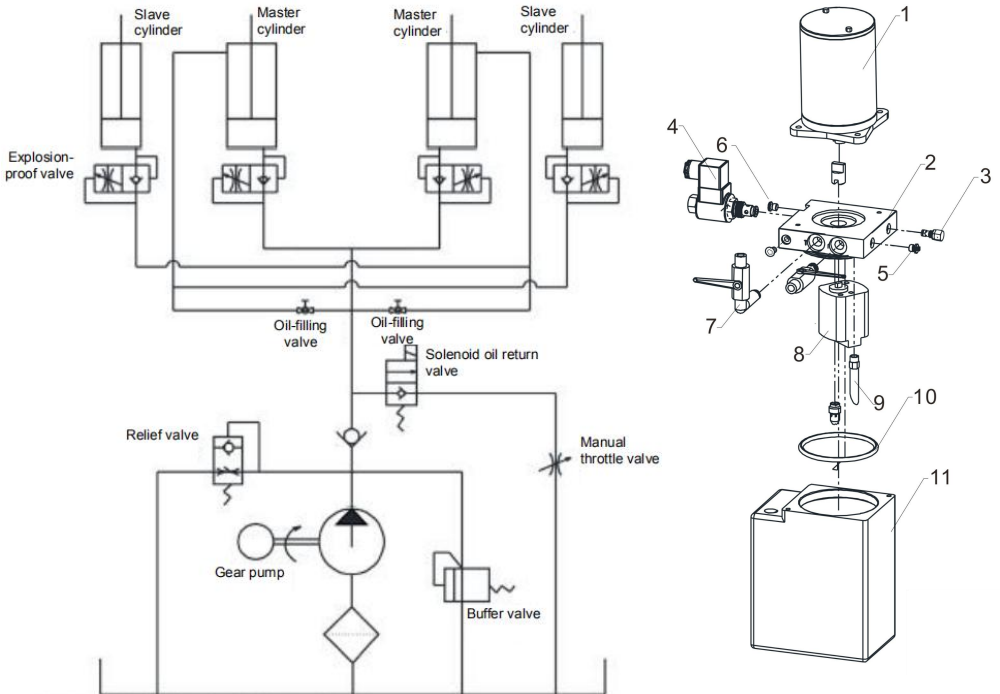

**Explosion-proof valve:** used to significantly reduce the speed of lowering after the blowout of oil pipe

**Oil-filling valve:** used to adjust the amount of oil in the slave cylinder **No.7**

**Solenoid oil return valve:** controlling the oil circuit for lowering **No.4**

**Manual throttle valve:** adjusting the speed of lowering **No.5**

**Relief valve:** controlling the maximum pressure **No.3**

**Gear pump:** supplying oil pressure **No.8**

**Buffer valve:** reducing the motor load when the motor starts **No.9**

## Chapter 4 Commissioning

- 1. Filling of hydraulic oil: Open the door of the control cabinet and fill the hydraulic tank with 16L 46# anti-wear and anti-freezing hydraulic oil (provided by the user) with a funnel.
- 2. Pipeline connection: Connect the oil pipe according to Oil Circuit Connection Diagram (the protection of the joint is the most critical during the process of connecting the oil pipe, and prevent the sand from entering the oil circuit).
- 3 Oil-filling and leveling: Turn on the power, press the UP button, check whether the motor runs in the correct direction, and finally fill oil and perform bleeding and leveling.
- 4. Installation and leveling: Lock the safety jaws in the safety teeth of the same level, adjust the spacing, fix the expansion screw (not installing the core), and after rough leveling, install the expansion screw core, and then perform fine leveling.
- Insert metallic sizing blocks under the platform to avoid the horizontal leveling of the lift on the uneven ground

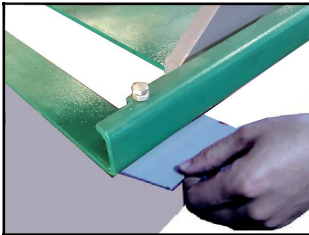

Fig. 15

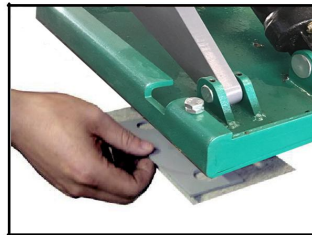

Fig. 16

- Drive a  $\Phi 18$  percussion bit to 160 mm depth in the ground from the holes on the base-plate with an electric hammer (Fig. 17), and clean the hole.
- Fix anchor bolts into the holes with a light hammer (without inserting the central expansion screws of the anchor bolts, which shall be fixed after the leveling is completed), as shown in Fig. 18

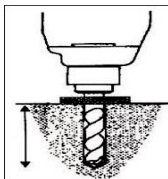

Fig. 17

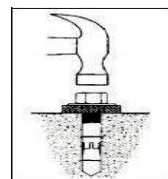

Fig. 18





- Lift the platforms to the fifth or sixth teeth, then press the “Lock” button to fasten the safety jaws of the left and right platforms into the safety gear racks firmly.
- Inspect that the surfaces of the left and right platforms are level laterally and longitudinally with a transparent leveling pipe or level gauge (Fig. 19).

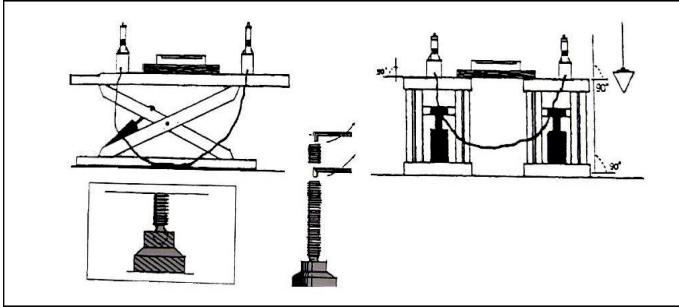

Fig. 19

If the uneven platform is caused by the uneven foundation, adjust the adjusting bolts (Fig. 20) on the baseplate of the main lift with a wrench.

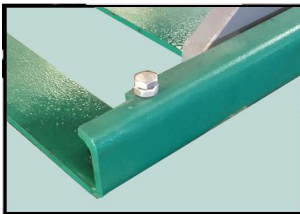

Fig. 20

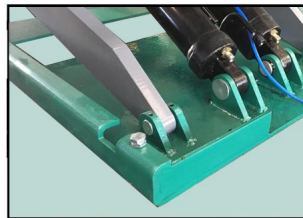

Fig. 21

- After the leveling, insert the central expansion screws of foundation bolts, and fix the expansion screws with a heavy hammer
- Tighten the nuts of the foundation bolts.
- Loosen the tightening nut first.
- Adjust the length of the supporting screw rod to the proper position.
- Then tighten the nut.



### 5. Trial loading:

After verifying that all the above operations are normal, drive a vehicle onto the lift and carry out trial loading, and if the result is normal, the lift can be put into normal use.

## **Chapter 5 Maintenance**

### **•5.1 Maintenance:**

- Add oil at all shaft crossovers in the machine once a month.
- Keep the safety gear rack clean.
- Keep the upper and lower pulleys clean and lubricate them.
- Change the hydraulic oil once a year. • Remove the waste in the tank.
- The compressed air pressure used for pneumatic unlocking of the safety lock is 6-8kg/cm<sup>2</sup>, which ensures the normal operation of the pneumatic solenoid valve.

### **•5.2 Operation cautions:**

- Before working, please make sure there are no foreign objects around or under the machine.
- During raising and lowering, no one can stand on the left or right of the lift or stand on or below the lift and no one can sit in the vehicle on the lift.
- Do not lift the vehicle that exceed the lifting capacity of the lift.
- During raising and lowering, apply the parking brake of the vehicle and place the rubber pads.
- During maintenance, "lock" the main and sub lifts in the safety teeth of the same level (press the "Lock" button).
- Always observe if the lift platforms act synchronously during raising and lowering. Shut down the machine in time if any abnormality is found, and restart the machine only after inspection and troubleshooting.
- If the DOWN button is pressed, the lift will be immediately lowered, then the safety jaw cylinder will be immediately opened due to the energized pneumatic solenoid valve, and the safety jaw will be immediately lifted. Therefore, during the lowering operation, be sure to raise the lift slightly so that the safety jaw and safety gear rack can be disengaged from each other, and then press the DOWN button to lower the lift.
- If the machine has not been used for a long time, inspect it before use.

### **•5.3 Electrical operation instructions:**

#### **•UP:**

- Press the "UP" button and the lift will rise immediately. At this point, the motor will start to run immediately, and the safety jaw cylinder will lift the safety jaw due to the energized pneumatic solenoid valve that opens the pneumatic circuit. When the UP button is released, the motor will stop running, the lift will immediately stop rising, and the safety jaw will fall on the safety gear rack due to the de-energized pneumatic solenoid valve that closes the pneumatic circuit.

#### **•DOWN:**

- Press the DOWN button and the lift will be lowered immediately, and the safety jaw cylinder will lift the safety jaw due to the energized pneumatic solenoid valve that opens the pneumatic circuit.

#### **•LOCK:**

- Press the LOCK button and the lift will be lowered immediately, and the safety jaw cylinder will not lift the safety jaw because the pneumatic solenoid valve is not energized, and the lift will be locked by the safety gear rack to enhance the safety of the operation.

•5.4 Oil-filling and leveling

### Adjustment of small ultrathin scissor lift

**Attention**  
**Make sure the motor turn in anticlockwise direction.**  
**Make sure connection oil cylinder is correct.**  
**Make sure the air lock work.**  
**Make sure turn off all the red handle valve.**

We suggest to use ISO-L-HM46(antifreeze type).  
 If the temperature below -10°, we suggest to use ISO-L-HM32(antifreeze type).



Two post lift —— 10L  
 Ingrounded small scissor lift —— 14L  
 Ongrounded small scissor lift —— 14L  
 Ongrounded double level scissor lift —— 16L  
 Ingrounded double level scissor lift —— 16L

Replace the oil in the first year.  
 Replace the oil ever two year except the first year.

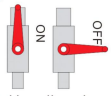

Red handle valve

1.Short connection J&E

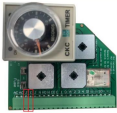

2. Turn on all the red handle valves(two valves).



3.Press "Down" button to make the lift lower to the bottom.

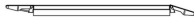

4.Press "Up" button to let all the lift to the toppest level (keep the red handle valve turning on).



5.Loosen the screws at the top of the main cylinders.(Open both side cylinders at the same time.)

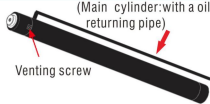

(Main cylinder:with a oil returning pipe)  
Venting screw

6.Press "UP" button to make more oil come out from the venting screw until only oil coming out form the cylinder instead of bubble.



Bubble

7. Turn off all the red handle valve.





8.Wait until no any bubble coming from the screws, tighten the screws.



No Bubble

9.Connect the PCB according to the left picture.

Up Limit: J&E  
 Sensors 1: S1&S2  
 Sensors 2: S2&S0

A	C	A	C	J	E	J	N	H	O	H	C	C	1	0	A	2	1	3	4	1	S	1	S	2	S	0	K	1	K	2	
														Up Limit														Sensors 2		Sensors 1	

•5.5 Emergency manual lowering procedures at power failure:

Lift the safety jaws above the cylinders for both platforms and put paper blocks under the safety jaws to separate them from the gear racks. Switch off the power and open the control cabinet door to locate the oil return solenoid valve. Loosen the copper cap at the end of the solenoid valve (2) so that the platforms can be lowered. When the platforms have been lowered, tighten the copper cap at the end of oil return solenoid valve timely to avoid unnecessary trouble. Otherwise, the hydraulic oil will directly return to the tank and thus cannot drive the cylinders to raise the lifts when the voltage is supplied normally for raising. Manual lowering is not recommended unless in case of emergency.



- Troubleshooting must be conducted by trained and experienced technicians.
- Fault symptoms and troubleshooting methods:

Fault symptom	Cause	Troubleshooting method
The motor does not rotate when the UP button is pressed.	① The power supply is abnormal	Perform inspection and troubleshooting, and connect the electric wires.
	② The AC contactor of the pump motor main circuit does not pull in.	The motor will run if the contactor is pressed with an insulating rod forcibly. Inspect the control circuit, and replace the contactor if the voltage at the contactor coil terminal is normal.
	③ Phase loss.	Use a multimeter to check if the three phases are 380V. Note: A tester can not be used to check if the phase is lost.
	④ The button switch is faulty.	Inspect the button contracts and wires and perform troubleshooting.
The motor rotates but the platform does not rise when the UP button is pressed.	① The motor rotates reversely.	Exchange the phase sequence of the incoming power wires.
	② The platform ascends with light load but does not ascend with heavy load.	Increase the safe pressure setting of the relief valve by rightward rotating the valve slightly. If there is dirt in the valve core of the lowering solenoid valve, clean the valve core.
	③ The hydraulic oil is insufficient or the grade is incorrect.	Refill or change the hydraulic oil.
	④ The manual oil drain plug of the solenoid valve is not tightened.	Tighten the oil drain plug of the main lift or sub lift.
	⑤ The solenoid valve connector is blown.	Replace the solenoid valve connector of the main lift or the sub lift.
The lift does not descend when the DOWN button is pressed.	① The safety jaw is not separated from the safety gear rack.	Extend the delay time of the time delay slightly.
	② The safety jaw is not uplifted.	The air pressure is insufficient, the safety jaw gets stuck or the air pipe is broken. Adjust the pressure of the air compressor, inspect the air pipe and perform troubleshooting.
	③ The pneumatic solenoid valve does not work.	If the pneumatic circuit is blocked for the energized pneumatic solenoid valve does not work, inspect or replace the pneumatic solenoid valve.
	④ The lowering solenoid valve does not work.	Inspect the connector and coil of the lowering solenoid valve and inspect whether the copper nut at the end of solenoid valve is rightward tightened.
	⑤ The explosion-proof valve is blocked.	Remove the "explosion-proof valve" from the oil inlet port at the cylinder bottom of main lift or sub lift cylinders, and clean explosion-proof valve.
The lift descends slowly with normal load.	① The hydraulic oil is too viscous or frozen and deteriorated (in winter).	Change the hydraulic oil or increase the room temperature according to the instruction.
	② The "explosion-proof valve" preventing the blowout of the oil pipe is blocked.	Remove or close the intake pipe to lock the safety jaw without lifting, remove the "explosion-proof valve" from the oil inlet port at the bottom of the oil cylinder and clean it.
The left and right platforms are out of sync and not at the same height.	① The air in the oil cylinder is not bled completely.	Refer to the procedures for oil filling and leveling.
	② The oil pipe or joint leaks oil.	Tighten the joint or replace the oil seal, and then fill oil and perform leveling.
	③ The "oil filling shutoff valve" can not be closed tightly, and therefore oil filling is required almost everyday.	Replace the oil filling shutoff valve, and then fill oil and perform leveling.
There is noise during raising and lowering.	① Insufficient lubrication.	Apply oil at all hinges and moving parts (including piston rods) to lubricate them.
	② The foundation or the machine is distorted.	Readjust the machine to make it level and fill (pad) the foundation.
The platform always rises when the Down button is pressed.	① The time relay is loose or damaged.	Reinsert or replace the time relay.

# Chapter 6 Exploded views

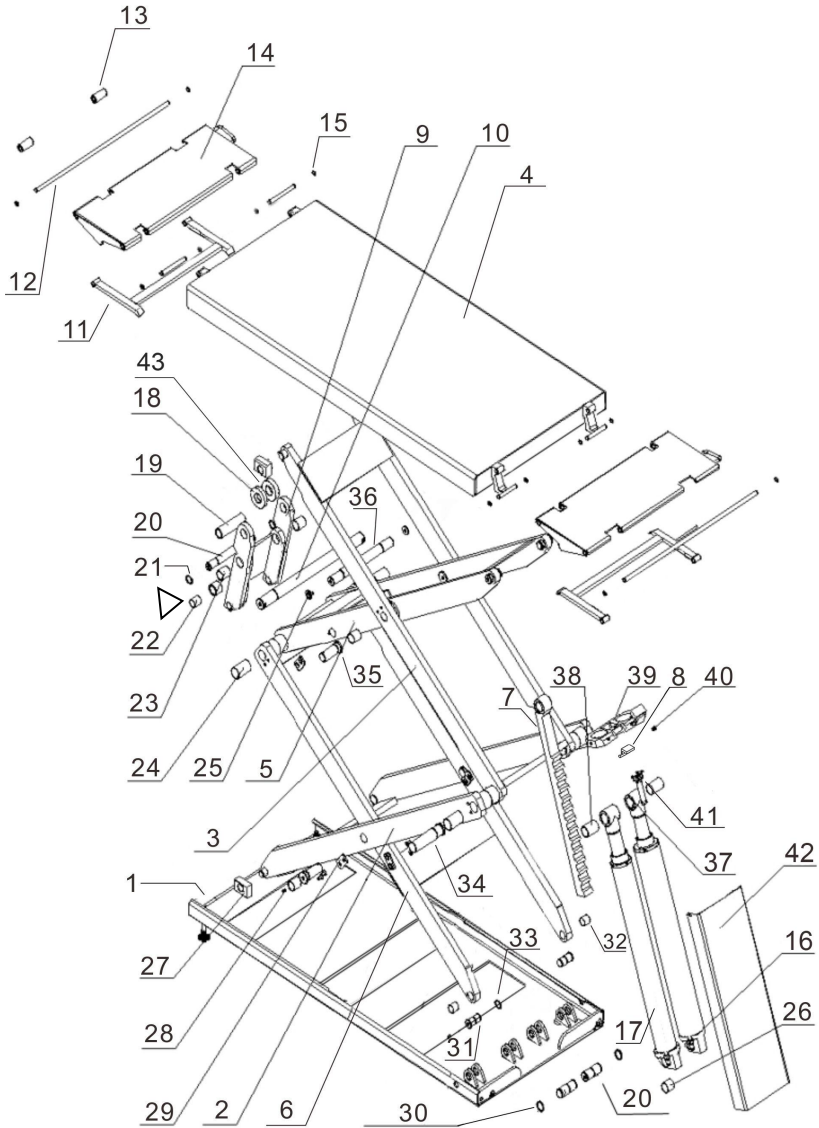

**10000LBS Ultra-thin Scissor Lift**

No.	Name	No.	Name
1	Base-plate	23	Auxiliary arm central bushing
2	Lower outer scissor arm	24	Scissor arm bushing
3	Upper outer scissor arm	25	Auxiliary arm central shaft Cir-clip
4	Pane	26	Oil cylinder tail shaft
5	Upper inner scissor arm	27	Lower sliding block
6	Lower inner scissor arm	28	Lower scissor arm central shaft
7	Safety gear rack	29	Lower scissor arm central bushing
8	Safety jaw	30	Oil cylinder bottom shaft cir-clip
9	Auxiliary arm	31	Lower scissor arm bottom shaft
10	Scissor arm connecting shaft	32	Lower scissor arm bottom bushing
11	Movable ramp knockout pin	33	Lower scissor arm bottom shaft Cir-clip
12	Movable ramp long shaft	34	Connecting shaft of upper and lower outer scissor arms
13	Movable ramp pulley	35	Upper scissor arm central shaft
14	Movable ramp	36	Auxiliary arm central shaft
15	Movable ramp shaft Cir-clip	37	Slave cylinder
16	Master cylinder	38	T bushing
17	Slave cylinder	39	Oil cylinder fixing plate
18	Auxiliary arm upper pulley (thin)	40	Lock screw of oil cylinder fixing plate
19	<b>Auxiliary arm upper shaft</b>	41	Safety jaw cylinder
20	Oil cylinder bottom shaft	42	Oil cylinder cover plate
21	Auxiliary arm cir-clip	43	Auxiliary arm upper pulley (thick)
22	Auxiliary arm lower pulley		

No.

Date

Handwriting practice lines consisting of a solid top line, a dashed middle line, and a solid bottom line, repeated down the page.



No.

.....

Date

.....

-----

-----

-----

-----

-----

-----

-----

-----

-----

-----

-----

-----

-----

-----

-----

-----

-----

-----

-----

-----

-----

-----

-----

-----

**10000LBS Ultra-thin Scissor Lift**

**SAE-UT10000**

**User's Manual**