

Vehicle and Boat Storage Four-Post Lift Installation and Operation Manual

Manual P/N 5900174 — Manual Revision D — March 2024

Models:

- HD-7500BLX
- HD-75BXT
- HD-7500PBX

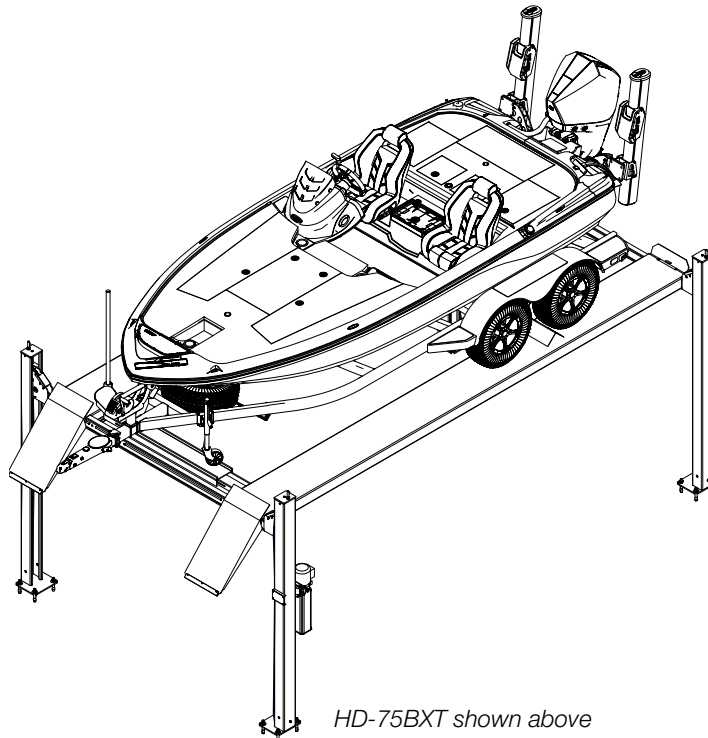

HD-75BXT shown above

*Original instructions in
the English language.*

Designed and engineered by BendPak Inc. in Southern California, USA. Made in China.

 **DANGER**

IMPORTANT SAFETY INSTRUCTIONS, SAVE THESE INSTRUCTIONS! Read the entire contents of this manual **before** using this product. Failure to follow the instructions and safety precautions in this manual can result in serious injury or death. Make sure all other operators also read this manual. Keep the manual near the product for future reference. **By proceeding with setup and operation, you agree that you fully understand the contents of this manual and assume full responsibility for product use.**

Manual. HD-7500BLX/HD-75BXT/HD-7500PBX Four-Post Lift series, *Installation and Operation Manual*, Manual P/N 5900174, Manual Revision D, released March 2024.

Copyright. Copyright © 2024 by BendPak Inc. All rights reserved. You may make copies of this document if you agree that: you will give full attribution to BendPak Inc., you will not make changes to the content, you do not gain any rights to this content, and you will not use the copies for commercial purposes.

Trademarks. BendPak and the BendPak logo are registered trademarks of BendPak Inc. All other company, product, and service names are used for identification only. All trademarks and registered trademarks mentioned in this manual are the property of their respective owners.

Limitations. Every effort has been made to ensure complete and accurate instructions are included in this manual. However, product updates, revisions, and/or changes may have occurred since this manual was published. BendPak reserves the right to change any information in this manual without incurring any obligation for equipment previously or subsequently sold. All drawings are reference only – do not scale. BendPak is not responsible for typographical errors in this manual. You can always find the latest version of the **manual for your product on the BendPak website.**



SCAN FOR
DIGITAL PDF

Warranty. The BendPak warranty is more than a commitment to you: it is also a commitment to the value of your new product. Contact your nearest BendPak dealer or visit www.bendpak.com/support/warranty for full warranty details. Go to bendpak.com/support/register-your-product/ and fill out the online form to register your product; be sure to click **Submit**.

Safety. Your product was designed and manufactured with safety in mind. Your safety depends on proper training and operation. Do not install, operate, maintain, or repair the unit without reading and understanding this manual and the labels on the unit; **do not use your Lift unless you can do so safely!**

Owner Responsibility. To ensure operator safety and maintain your product properly, it is the responsibility of the product owner to read and follow these instructions:

- Follow all setup, operation, and maintenance instructions.
- Make sure product setup and use conforms to all applicable local, state, and federal codes, rules, and regulations, such as state and federal OSHA regulations and electrical codes.
- Read and follow all safety instructions. Keep them readily available for operators.
- Make sure all operators are properly trained, know how to safely operate the unit, and are properly supervised.
- Do not operate the product until you are certain all parts are in place and operating correctly.
- Carefully inspect the product on a regular basis and perform all maintenance as specified.
- Service and maintain the unit only with approved replacement parts.
- Keep all instructions permanently with the product and make sure all labels are clean and visible. BendPak makes no promises, guarantees or assurances that our products meet any state, county, federal or international mandated permit, license, code, standard, certification, or any other mandate other than what is listed or shown on BendPak website(s), or any BendPak or Ranger online or published catalog. Not all BendPak lift models meet the standards as prescribed by ANSI/ALI ALCTV-(current edition) or ANSI/UL 201. Consult www.autolift.org for a complete list of lift models that meet ANSI/ALI ALCTV-(current edition) or ANSI/UL 201 or contact BendPak via contact@bendpak.com. Buyer assumes full responsibility for any state, county, federal or international mandated permit, license, code, standard, certification, or any other mandate required related to the installation and/or operation of any BendPak or Ranger product. BENDPAK will not be responsible for any charges, fines, liens, or other levies imposed on the Buyer related to any special or regional structural, seismic or any other building code and/or codes such as the Uniform Building Code (UBC), International Building Code (IBC), or any other state, county, federal or international mandated permit, license, code, standard, certification, or other mandate, law, rule, regulation or directive by any other agency, government, administrations, or corporations whether state, county, federal, or international mandated.



- **Only use the Lift if it can be used safely!**

Unit Information. Enter the Model Number, Serial Number, and the Date of Manufacture from the label on your unit. This information is required for part or warranty issues.

Model: _____

Serial: _____

Date of Manufacture: _____

BP BendPak		Santa Paula, CA USA www.bendpak.com
MODEL NUMBER		
DESCRIPTION		
LIFT CAPACITY	DATE OF MFG.	
ROLLING JACK MAX CAP.	MAX PSI / BAR	
VOLTAGE		SERIAL NUMBER
<input type="checkbox"/> 110-240V, 50-60 Hz, 1 Ph <input type="checkbox"/> 208-240V, 50-60 Hz, 1 Ph <input type="checkbox"/> 380-415V, 50-60 Hz, 3 Ph <input type="checkbox"/> 208-440V, 50-60 Hz, 3 Ph		
		UPC
 DANGER! <small>Disconnect Power Before Servicing</small>		
WARRANTY VOID IF DATA PLATE IS REMOVED PN 5905952		

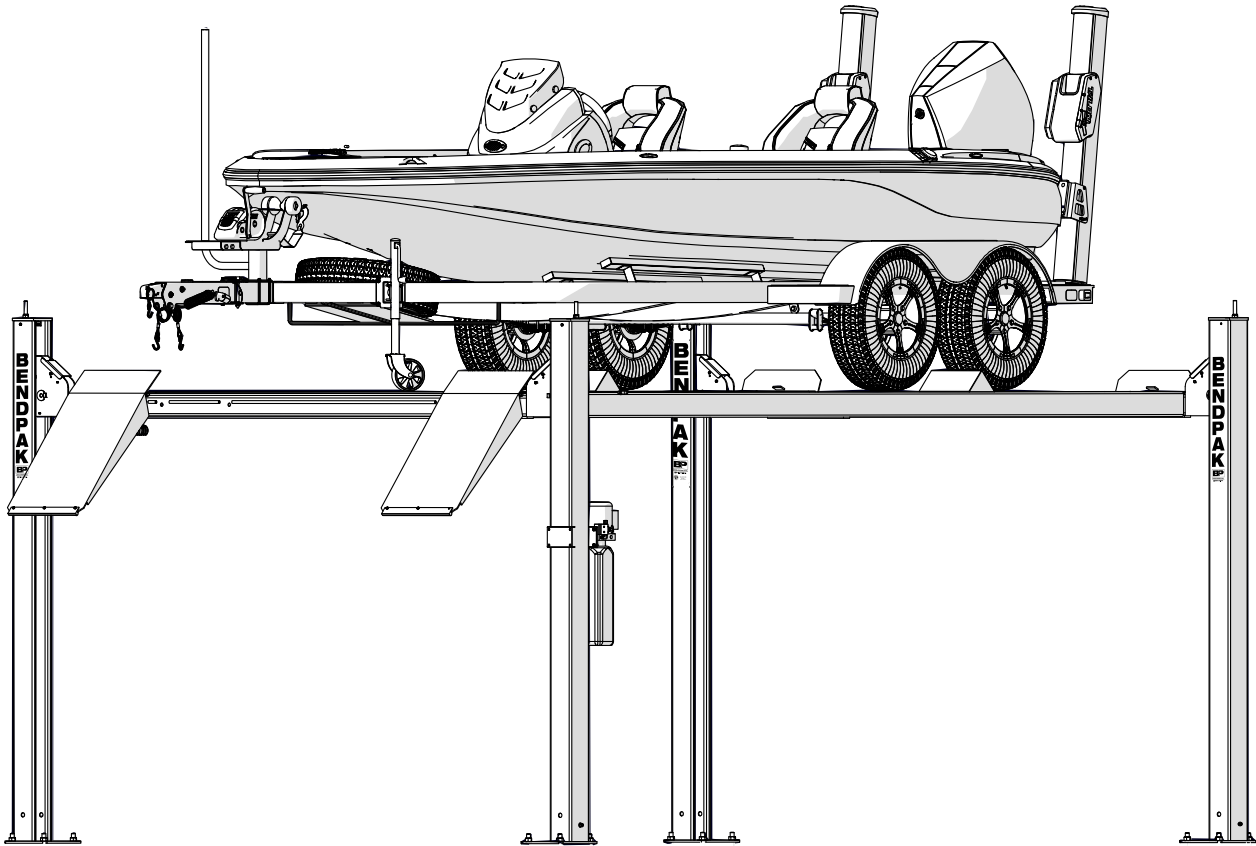

Table of Contents

Introduction	4	Operation	73
Shipping Information	5	Maintenance	76
Safety Considerations	5	Troubleshooting	79
Components	8	Wiring Diagrams	81
Specifications	10	Labels	83
FAQs	12	Parts Drawings	86
Installation Checklist	13	Maintenance Log	102
Installation	14		

Introduction

This manual describes the following BendPak Four-Post Lifts:

- **HD-7500BLX:** Four-Post Lift with an overall width of 133.76 in. (3,398 mm), length of 198 in. (5,029 mm), and lifting height of 87 in. (2,210 mm). The lift is capable of raising Vehicles and Boats up to 7,500 lbs. (3,402 kg). Supplied with a Boat Trailer Tongue Platform. Runways may be configured in a wide or narrow version.
- **HD-75BXT: Extended Length,** Four-Post Lift with an overall width of 133.76 in. (3,398 mm), length of 222 in. (5,639 mm), and lifting height of 87 in., (2,210 mm). The Lift is capable of raising Vehicles and Boats up to 7,500 lbs. (3,402 kg). Supplied with a Boat Trailer Tongue Platform. Runways may be configured in a wide or narrow version.
- **HD-7500PBX: Extended Height,** Four-Post Lift with an overall width of 132.165 in. (3,398 mm), length of 198 in., (5,029 mm) and lifting height of 145 in., (3,683 mm). The Lift is capable of raising Vehicles and Boats up to 7,500 lbs. (3,402 kg). The HD-7500PBX **does not include** a Boat Tongue Platform. Runways may be configured in a wide or narrow version.

This manual is mandatory reading for all users of the HD-7500BLX, HD-75BXT and/or the HD-7500PBX, including anyone who installs, uses, maintains, repairs, or wants to know more about them.

 **DANGER** Use care when installing, operating, maintaining, or repairing this equipment; failure to do so could result in property damage, product damage, injury, or (in very rare cases) death. Make sure only authorized personnel operate this equipment. An authorized technician must perform all repairs. Do not make modifications to the unit; this voids the warranty and increases the chances of injury or property damage. Make sure to read and follow the instructions in this manual and on the labels on the unit.

Technical support and service is available from your dealer, on the Web at bendpak.com/support, by email at support@bendpak.com, or by phone at **(800) 253-2363** select option 7, then 4. Online chat is also available at www.bendpak.com click the chat icon.



Scan this QR Code for up-to-date information and videos on the BendPak Four-Post Lifts.

Shipping Information

Your equipment was carefully checked before shipping. Nevertheless, you should thoroughly inspect the shipment **before** you sign to acknowledge that you received it.

When you sign a bill of lading, it tells the carrier that the items on the invoice were received in good condition. *To protect yourself, do not sign until after you have inspected the shipment.* If any of the items listed on the bill of lading are missing or are damaged, do not accept the shipment until the carrier makes a notation on the bill of lading that lists the missing and/or damaged goods.

If you discover missing or damaged goods **after** you receive the shipment and have signed the bill of lading, notify the carrier at once and request the carrier to make an inspection. If the carrier will not make an inspection, prepare a signed statement to the effect that you have notified the carrier (on a specific date), and that the carrier has failed to comply with your request.

It is difficult to collect for loss or damage after you have given the carrier a signed bill of lading. If this happens to you, file a claim with the carrier promptly. Support your claim with copies of the bill of lading, freight bill, invoice, and photographs, if available. Our willingness to assist in helping you process your claim does not make us responsible for collection of claims or replacement of lost or damaged materials.

Safety Considerations

Read this entire manual carefully before using your new product. Do not install or operate the Lift until you are familiar with all operating instructions and warnings. Refer to ANSI/ALI ALIS Standard *Safety Requirements for Installation and Service of Automotive Lifts* for more information about safely installing your Lift.

⚠ WARNING California Proposition 65. This product can expose you to chemicals including styrene and vinyl chloride which are on the list of over 900 chemicals identified by the State of California to cause cancer, birth defects or reproductive harm. **ALWAYS** use this product in accordance with BendPak's instructions. For more information go to www.P65Warnings.ca.gov.

Important Safety Instructions!

Save these instructions!





1. Read all instructions.
2. Care must be taken as burns can occur from touching hot parts.
3. Do not operate equipment with a damaged cord or if the equipment has been dropped or damaged – until a qualified service person has examined it.
4. Do not let a cord hang over the edge of a table, bench, or counter or come in contact with hot manifolds or moving fan blades.

-
5. If an extension cord is necessary, a cord with a current rating equal to or more than that of the equipment should be used. Cords with a current rating less than the equipment may overheat. Care should be taken to arrange the cord so that it will not be tripped over or pulled.
 6. Always unplug the equipment from the electrical outlet when not in use. Never use the cord to pull the plug from the outlet. Grasp the plug and pull to disconnect.
 7. Let the equipment cool completely before putting away. Loop cord loosely around equipment when storing.
 8. To reduce the risk of fire, do not operate in the vicinity of open containers of flammable liquids (gasoline).
 9. Adequate ventilation should be provided when working on operating internal combustion engines.
 10. Keep hair, loose clothing, fingers, and all parts of body away from moving parts.
 11. To reduce the risk of electric shock, do not use on wet surfaces or expose to rain.
 12. Use only as described in this manual. Use only BendPak recommended attachments.
 13. ALWAYS WEAR SAFETY GLASSES. Everyday eyeglasses only have impact resistant lenses, they are not safety glasses.
 14. To reduce risk of injury, close supervision is necessary when this product is used around children.
 15. To reduce the risk of injury, **never** attempt to lift more than the rated capacity. Refer to loading instructions.
 16. The Lift uses electrical energy; if your organization has Lockout/Tagout policies, make sure to implement them after connecting the Lift to a power source.
 17. Refer to markings for proper load on electrical receptacles.
 18. Only operate your Lift between temperatures of +41°F to +104°F (+5°C to +40°C).
 19. The Lift should **only** be operated by authorized personnel. Keep children and untrained personnel away from the Lift.
 20. Do not make any modifications to the Lift; this voids the warranty and increases the chances of injury or property damage.
 21. Do not use the Lift while tired or under the influence of drugs, alcohol, or medication.
 22. Consider the work environment. Keep the work area clean. Cluttered work areas invite injuries. Keep areas well lit.
 23. **Always** ensure the Lift is secured on Safety Locks before working on or near a Vehicle.
 24. Make a thorough inspection of the product at least once a year. Replace any damaged or severely worn parts, decals, or warning labels. Replace worn or damaged parts with BendPak or BendPak approved parts and assemblies only.
 25. BendPak recommends referring to the ANSI/ALI ALIS Standard *Safety Requirements for Installation and Service* for more information about safely installing, using, and servicing your Lift.
 26. The **HD-750BLX/HD-75BXT/HD-7500PBX** Lifts are Parking Lifts. **Use each model only for their intended purposes.**
 27. You **must** wear OSHA-approved (publication 3151) personal protective equipment at all times when installing, using, maintaining, or repairing the Lift. Leather gloves, steel-toed work boots, eye protection, back belts, and hearing protection are **mandatory**.

-
28. Keep loads balanced on the Platforms. Clear the area immediately if a Vehicle is in danger of falling off the Lift.
 29. Modifications void the warranty and increases the chances of injury or property damage. Do not modify any safety-related features in any way. Do not make any modifications to the Lift.
 30. Make sure all operators read and understand this Installation and Operation Manual. Keep the manual near the Lift at all times.
 31. While handling a Hydraulic Cylinder or a Hydraulic Hose, **always** wear gloves. In rare cases, a needle-like stream of hydraulic fluid (even at low pressure) can penetrate fingers, hands, or arms; such a puncture can feel like a bite, electric shock, or a prick. While it may seem like a minor issue, any amount of Hydraulic Fluid injected into the human body is a serious issue. Anyone suffering such a puncture wound should be **immediately** taken to a hospital emergency room to determine the extent of the injury. Explain the circumstances of the injury to the attending physician, including what kind of Hydraulic Fluid was involved. Do not assume a puncture wound that could have been caused by Hydraulic Fluid is a minor issue; it could be life threatening.
 32. Make an inspection of the Lift **before** using it. Check for damaged, worn, or missing parts. Do not use it if you find any of these issues. Instead, take it out of service, then contact an authorized repair facility, your dealer, or BendPak at **(800) 253-2363**, select option 7 then 4, or support@BendPak.com.
 33. To reduce the risk of property damage, personal injury, or loss of life, **NEVER** park any vehicle on the Lift's runways without placing suitable Wheel Chocks behind each rear tire so that the vehicle cannot roll backwards off the Lift. Vehicles parked on the Lift **MUST** also be placed in Park or First Gear (Manual Transmission) with the Parking Brake fully applied.

Symbols

Following are the symbols used in this manual:

-  **DANGER** Calls attention to an immediate hazard that **will** result in injury or death.
-  **WARNING** Calls attention to a hazard or unsafe practice that **could** result in injury or death.
-  **CAUTION** Calls attention to a hazard or unsafe practice that **could** result in minor personal injury, product, or property damage.
- NOTICE** Calls attention to a situation that if not avoided, may cause property damage.
-  **Tip** Calls attention to information that can help you use your product better.

Liability Information

BendPak Inc. assumes **no** liability for damages resulting from:

- Use of the product for purposes other than those described in this manual.
- Modifications to the equipment without prior, written permission from BendPak Inc.
- Injury or death caused by modifying, disabling, overriding, or removing safety features.
- Damage to the equipment from external influences.
- Incorrect operation of the equipment.

Components

HD-7500BLX HD-75BXT

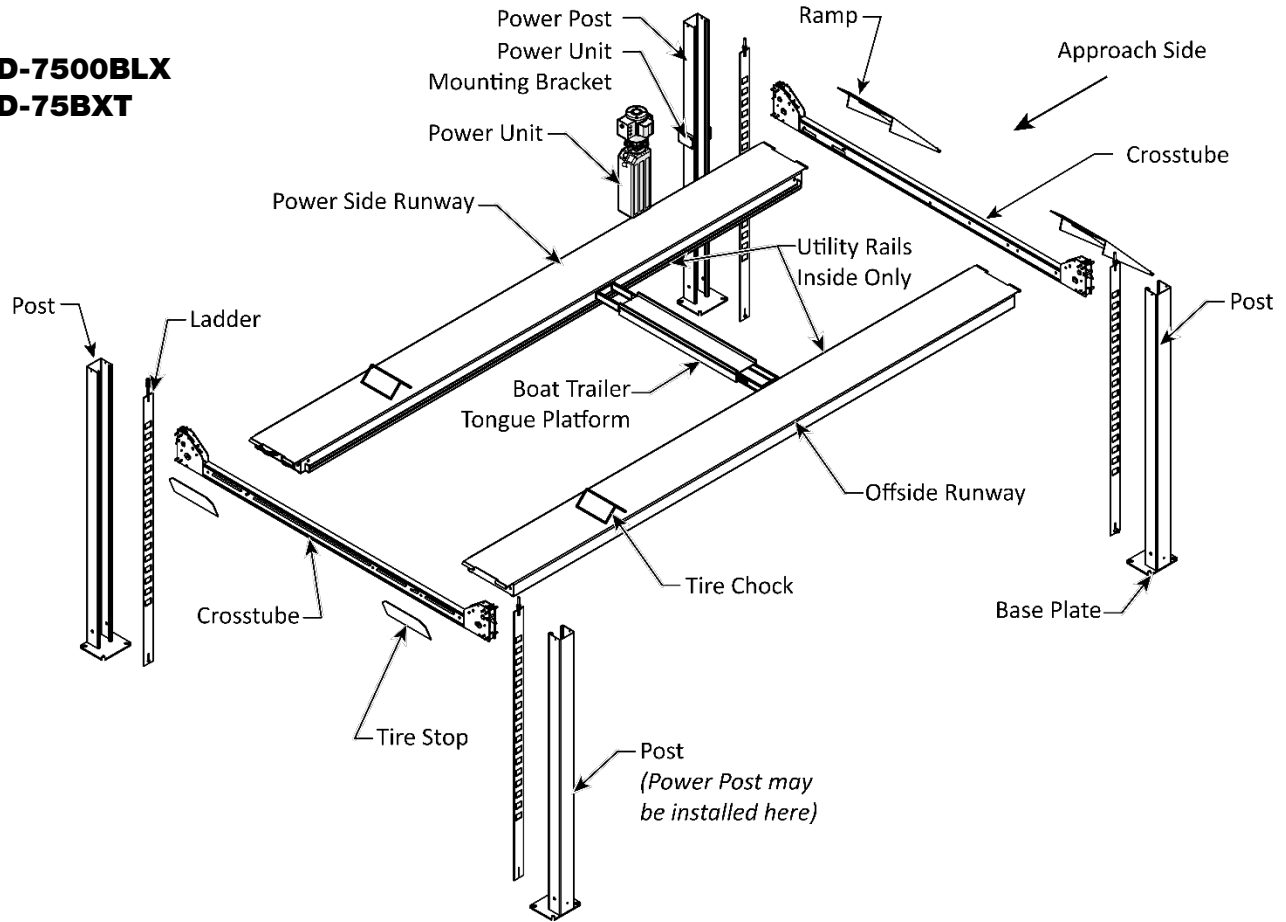

HD-7500PBX

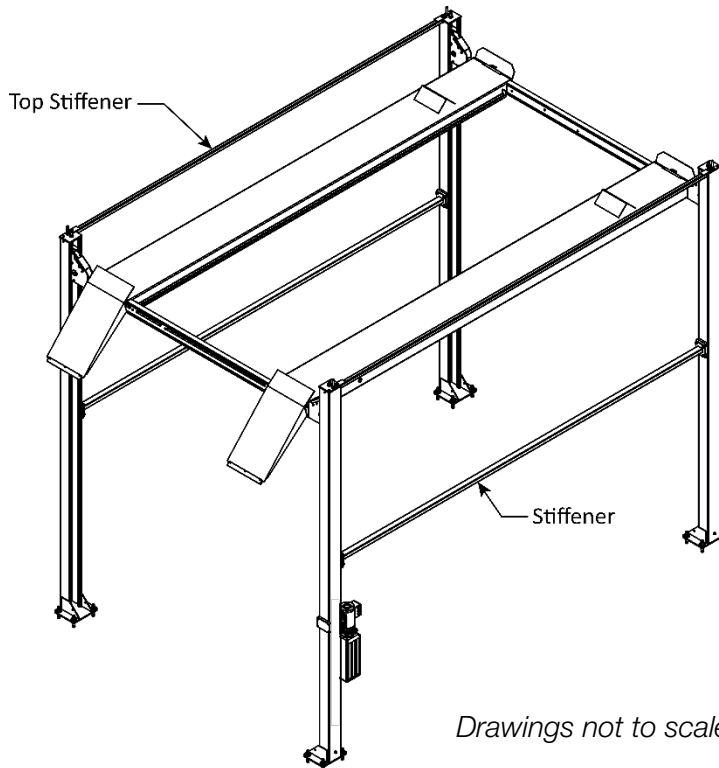

Drawings not to scale. Components removed for clarity.

Components

The main components of your Lift include:

- **Power Post.** The Post that supports the Power Unit. **The Power Post can be situated in one of two locations.** You can tell the Power Post from the other Posts because it has two Mounting Brackets on it. Mount the Power Unit on one of the two Mounting Brackets.
- **The other three Posts.** The remaining three Posts are functionally interchangeable.
- **Power Unit.** An electric/hydraulic unit that connects to an electric power source and then provides hydraulic power to the Hydraulic Cylinder that raises and lowers the Runways.
- **Lifting Cables.** The two Runways are lifted by 0.4 inch / 10 mm thick aircraft-quality steel wire rope, *each* of which is rated at 14,400 pounds.
- **Boat Trailer Tongue Platform.** Mounts between the Runways and supports the front jack of your boat trailer.
- **Power Side Runway.** The Runway next to the Power Post. The Power Side Runway has Lifting Cables and the Hydraulic Cylinder on its underside. You **must** put the Power Side Runway next to the Power Post.
- **Offside Runway.** The other Runway. It does not have a Hydraulic Cylinder or Lifting Cables under it.
- **Utility Rails.** Supports the optional Rolling Jacks. Utility Rails **must** be positioned on the inside of the Lift.
- **Crosstubes.** One at each end of the Lift. The Crosstubes are hollow; the Lifting Cables that raise and lower the Runways are routed through the Crosstubes. The Crosstubes are not interchangeable: each Crosstube has openings (called a Windows) that allow space for the Cable Sheaves. Orienting the Windows correctly is described in the Installation section. **Windows must be installed so that they open to the inside of the Lift.** Lifting Cables are routed into the Crosstubes through the Windows.
- **Ramps.** One for each Runway. Use them to drive onto and off of the Runways. The Ramp end of the Lift is also the Rear of the Lift.
- **Tire Stops.** Located at the Front of the Lift, Tire Stops prevent the Vehicle's front tires from going any farther forward. Additionally, we strongly recommend chocking the Vehicle's rear tires.
- **Safety Locks.** Once engaged, they hold the Runways in position, even if the power is out or if there is a leak in the Hydraulic Hoses. **Only leave your Lift on the ground or engaged on a Safety Lock.**
- **Pushbutton Air Valve.** Includes a Pushbutton that moves the Safety Locks away from the Ladder so that they do not engage as you lower the Runways. Used only to lower the Runways.
- **Ladder.** A steel assembly with openings designed to engage the safety locks. Installed inside each post.
- **Stiffeners.** The **HD-7500PBX** includes stiffeners mounted between the Posts to provide additional support.

Specifications

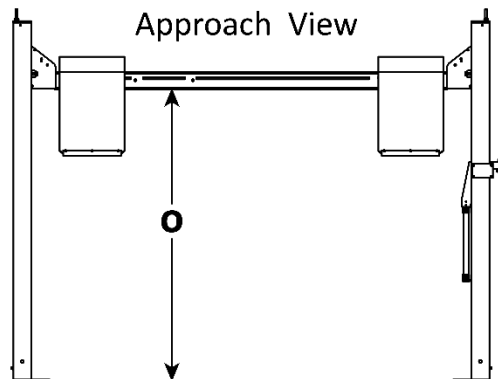
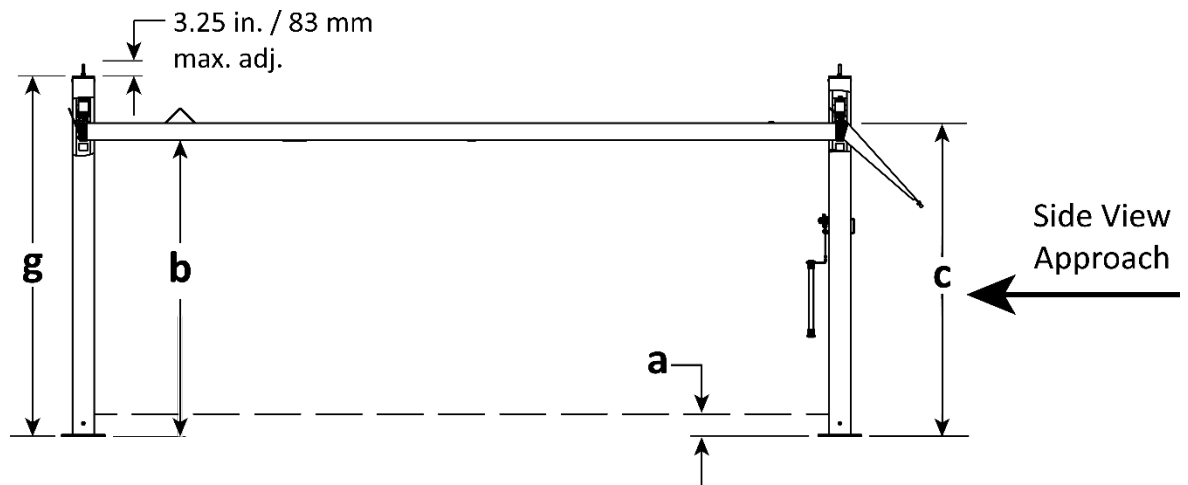
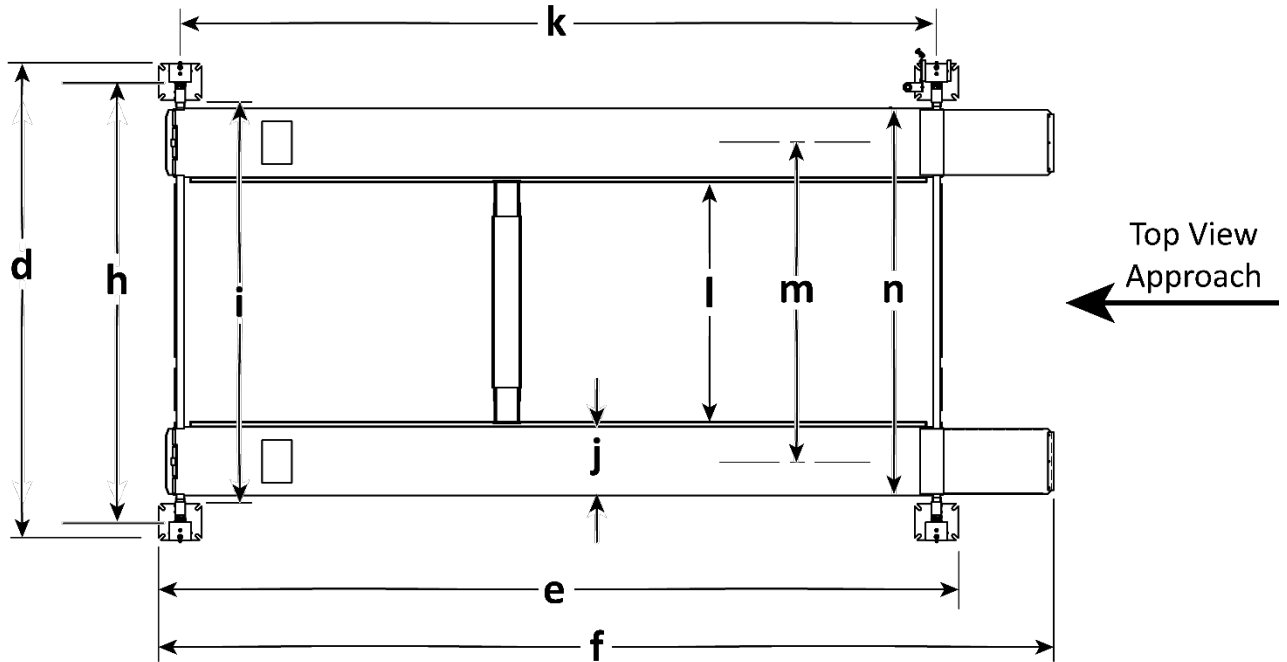

Model:	HD-7500BLX	HD-75BXT	HD-7500PBX
Lifting capacity	7,500 lbs. / 3,402 kg		
Maximum capacity front axle	3,750 lbs. / 1,701 kg		
Maximum capacity rear axle	3,750 lbs. / 1,701 kg		
a Min. Runway Height, Lowered	5 in. / 125 mm		
b Maximum Rise	82 in. / 2,082 mm	82 in. / 2,082 mm	140 in. / 3,560 mm
c Maximum Lifting Height	87 in. / 2,208 mm	87 in. / 2,208 mm	145 in. / 3,681 mm
d Overall Width (see note 2)	133.76 (±.125) in. / 3,397.5 (±3.2) mm		132.165 (±.125) in. / 3,357 (±3.2) mm
e Outside Length	198 in. / 5,028 mm	222 in. / 5,638 mm	198 in. / 5,028 mm
f Overall Length	224.5 in. / 5,703 mm	248.5 in. / 6,313 mm	224.5 in. / 5,703 mm
g Height of Post (see note 3)	100 in. / 2,537 mm		157.9 in. / 4,010 mm
h Distance Between Posts	122.165 in. / 3,103 mm		
i Drive-Through Clearance, Width	108.5 in. / 2,758 mm		
j Runway Width	19 in. / 482 mm		
k Runway length	182.25 in. / 4,629 mm	206.25 in. / 5,239mm	182.25 in. / 4,629mm
l Width Between Runways	46.5 in. – 66.5 in. / 1,181 mm – 1,689 mm		
m Runway Centerline	68.5 in. (narrow) <i>or</i> 88.5 in. (wide) / 1,740 mm <i>or</i> 2,247 mm		
n Outside Edge of Runways	87.5 in. (narrow) <i>or</i> 107.5 in. (wide) / 2,221 mm <i>or</i> 2,728 mm		
o Drive-Thru Clearance, Height	81 in. / 2,055 mm		139 in. / 3,528 mm
Min. Wheelbase @ rated capacity ¹	130 in. / 3302 mm	150 in. / 3,810 mm	130 in. / 3302 mm
Min. Wheelbase @ 75% capacity ¹	110 in. / 2794 mm	130 in. / 3,302 mm	110 in. / 2794 mm
Min. Wheelbase @ 50% capacity ¹	95 in. / 2413 mm	110 in. / 2,794 mm	95 in. / 2413 mm
Min. Wheelbase @ 25% capacity ¹	75 in. / 1,905 mm	90 in. / 2,286 mm	75 in. / 1,905 mm
Locking Positions	17 spaced every 4 in. / 102 mm		
Lifting time	≈50 seconds		
Motor	208-230 VAC, 60 Hz, 1 Ph., 18 Amps, 3 HP.		
Air supply	3 to 25 cfm at 50 to 150 psi max.		

¹ The Lift supports less weight than its rated capacity as the Vehicle's wheelbase is reduced. This reduction in capacity is due to the vehicle's wheels moving closer to the middle of the Runways, where less structural support exists. For example, the maximum weight allowed on the HD-75BXT for a Vehicle with a wheelbase of 110 inches is 50 percent of the Lift's rated capacity or 3,750 lbs.

² The Safety Ladder fasteners extend horizontally past the Post by .75 in. / 19 mm on all four Posts. This larger dimension should not be used to create the Chalk Lines for the Lift Installation, but the additional clearance is required around all four Posts.

³ The Safety Ladder adjustment adds an additional 3.25 inches max. to the Post height.

Specifications subject to change without notice.

Frequently Asked Questions

Question: What kinds of Vehicles can I put on my Lift?

Answer: Cars, trucks, SUVs; most vehicles that fit on the Runways and weigh up to 7,500 lbs. (3,402 kg) and boat trailers using the TC-3000 Trailer Tongue Assembly.

Q: How long does it take to raise or lower my Lift with a Vehicle on it?

A: About 50 to 55 seconds. Lowering times increase if there is no weight on the Lift.

Q: Does the Lift have a Front and a Rear?

A: Yes. For a Four-Post Lift, the end **opposite** the Ramps is the Front; the end with the Ramps is the Rear.

Q: Do I need to put my Power Unit in a particular location?

A: Yes. Your Power Post (the Post that holds the Power Unit) must be located at either the Driver-Side Front, or the Passenger-Side Rear of the Lift.

Q: Does the Lift need to be anchored in place?

A: Yes. Required that you anchor the Lift; it may be less stable if you do not anchor the Bases.

Q: How high does the ceiling need to be?

A: It depends on the height of the Vehicle you are putting on the Runways and how high you raise the Runways. If you are going to put a tall Vehicle or Boat on the Lift and raise it all the way up, you should check to make sure there is enough room above.

Q: Does it matter if I drive my Vehicles in front first, or back them in?

A: We recommend driving your Vehicle in front first, because that makes it easier to center the wheels on the Runways. But it is up to you; the Lift works great either way. **NEVER** park any vehicle on the Lift's runways without placing two suitable wheel chocks behind each rear tire so that the vehicle cannot roll off the Lift.

Q: Will the Lifting Cables really hold my Vehicle?

A: Yes. Each Lifting Cable is 0.4 inches thick, aircraft-quality steel **wire rope**.

Q: Do I need an Air Supply?

A: Yes. An Air Supply (3 to 25 cfm at 50 to 150 psi) is required to disengage the Safety Locks when you want to lower the Lift. Regulate the line to a maximum pressure of 150 psi; the Air Lines could burst or the Safety Locks malfunction at pressures over 150 psi.

Q: How long can I leave a Vehicle on a raised Runway?

A: As long as needed. Once the Lift is engaged on a Safety Lock, gravity holds it in position, so a loss of power or a leaking Hydraulic Hose will not affect the Lift. **Only leave your Lift fully lowered or engaged on all four Safety Locks.**

Q: Can I install my Lift outside?

A: No. Your Lift is approved for indoor installation and use only. **Outdoor installation is prohibited.**

Installation Checklist

Following are the steps needed to install your Lift. Perform them in the order shown.

- 1. Review the Safety Rules.
- 2. Make sure you have the necessary Tools.
- 3. Plan for electrical work.
- 4. Select the Installation Location.
- 5. Choose a Power Post Location.
- 6. Check the Clearances above the Vehicle.
- 7. Check the Clearances around the Lift.
- 8. Unload and unpack the Lift Components.
- 9. Create Chalk Line Guides.
- 10. Move the Posts into position.
- 11. Install the Crosstubes and Slide Blocks.
- 12. About Safety Locks.
- 13. Install the Ladders and Top Caps.
- 14. Raise the Posts and Crosstubes.
- 15. Install stiffeners **HD-7500PBX** only.
- 16. Secure the Ladders.
- 17. Remove the Sheaves.
- 18. Install the Runways.
- 19. Install the First End of the Flex Tube.
- 20. Extend the Piston
- 21. Route the Lifting Cables **HD-7500BLX** & **HD-75BXT**.
- 22 Route the Lifting Cables **HD-7500PBX**.
- 23. Install the Power Unit.
- 24. About Hydraulic Fluid Contamination.
- 25. Hydraulic System Warnings
- 26. About Thread Sealants.
- 27. Fill the Hydraulic Fluid Reservoir.
- 28. Install the Second End of the Flex Tube.
- 29. Working with Compression Fittings and Tubing.
- 30. Install the Pushbutton Air Valve and connect the Air Line.
- 31. Connect the Return Line.
- 32. Connect the Hydraulic Hose.
- 33. Contact the Electrician.
- 34. Connect to a power source (**Electrician required**).
- 35. Install the Power Disconnect Switch and Thermal Disconnect Switch (**Electrician required**).
- 36. Lift Start-Up
- 37. Anchor the Posts.
- 38. About Effective Embedment.
- 39. Install the Anchors
- 40. Perform Final Leveling.
- 41. Install the Accessories.
- 42. Lubricate the Lift.
- 43. Perform an Operational Test.
- 44. Review the Final Checklist.

Installation

The installation process requires multiple steps. Perform them in the order listed.

Read the entire Installation section before beginning the installation; this will provide a better understanding of the assembly process.

 **WARNING** **Only use the factory-supplied parts delivered with your Lift.** If you use parts from a different source, you void your warranty and compromise the safety of everyone who installs or uses the Lift. If you are missing parts, visit bendpak.com/support or call **(800) 253-2363** select option 7, then 4.

Safety

While installing this equipment, your safety depends on proper training and thoughtful operation.

 **WARNING** Do not install this equipment unless you have Automotive Lift installation training. Always use proper lifting tools, such as a Forklift or Shop Crane, to move heavy components. Do not install this equipment without reading and understanding this manual and the safety labels on the unit.

Only fully trained personnel should be involved in installing this equipment. Always pay attention. Use appropriate tools and lifting equipment. Stay clear of moving parts.

BendPak recommends referring to the current version of the ANSI/ALI ALIS Standard *Safety Requirements for Installation and Service of Automotive Lifts* for more information about safely installing, using, and servicing your Lift.

 **WARNING** You must wear appropriate protective equipment **at all times** during installation: gloves, steel-toed work boots, eye protection, back belts, and hearing protection.

 **WARNING** **Slippery When Wet** Any wet lift surfaces or adjacent wet concrete areas, create slipping hazards for both personnel and moving vehicles. Use extreme caution around all wet areas.

Tools

You may need some or all the following tools and supplies:

- Rotary hammer drill (or similar)
- ¾ in. masonry drill bit (ANSI B212.15)
- Hammer, crowbar, and two sawhorses
- Four-foot level and 12-foot ladder
- Open-end wrench set, SAE, and metric
- Socket and ratchet set, SAE, and metric
- Hex key wrench set
- Medium crescent wrench, torque wrench, pipe wrench
- Chalk line
- Medium-sized flat screwdriver and needle-nose pliers
- Tape measure (25 feet or more)
- Forklift, or shop crane
- Red and White Lithium Grease

Plan for Electrical Work

A licensed Electrician will be required at some point during the installation.

⚠ DANGER A licensed Electrician must perform all electrical work.

Notify the Electrician in advance so that they arrive prepared with appropriate components for connecting to the facility power source, a Power Disconnect Switch, and a Thermal Disconnect Switch. Refer to **Contacting the Electrician** for more information. The Electrician is required to:

- **Connect the Power Unit to an electrical power source.** The Power Unit is delivered with a Pigtail for wiring to a power source. Have your Electrician connect a power cord with appropriate plug to the electrical box on the Lift (for connection to a power outlet) or have them wire it directly into the electrical system at the Lift location protected by an appropriate circuit breaker.

Note that *installing* the Power Unit and *connecting* the Power Unit to the power source are separate procedures and are done at different times in the installation process. You do **not** need an Electrician to *install* the Power Unit, but an Electrician is **required** to connect the Power Unit to the power source.

Note: The Power and Thermal disconnects are not supplied with the Lift.

- **Install a Power Disconnect Switch.** This switch is an NEC requirement and ensures the operator can quickly and completely interrupt electrical power to the Lift in the event of an electrical circuit fault, emergency, or when equipment is undergoing service or maintenance. Install the disconnect within sight and reach of the Lift operator.
- **Install a Thermal Disconnect Switch.** The thermal disconnect ensures the equipment shuts down in the event of an overload or an overheated motor.

Select a Location

When selecting the location for your Lift, consider:

- **Allow Room to Back a Boat and Trailer onto the Lift while connected to a Tow Vehicle.** Allow a sufficient distance to approach the Lift while backing **both** the boat trailer and tow-vehicle combination, on an unobstructed and straight path.
- **Architectural plans.** Consult the architectural plans for the desired installation location. Make sure there are no conflicts between the desired location and what the plans will allow.
- **Available space.** Make sure there is enough space for the Lift: front, back, sides, and **above**. Refer to **Specifications** for measurements.
- **Overhead obstructions.** Check for overhead obstructions such as building supports, heaters, electrical lines, low ceilings, hanging lights, and so on. **Make sure that Vehicles on the Lift WILL NOT hit obstructions and have more-than-adequate ceiling clearance.**
- **Side and front clearances.** You must leave room around the Lift. Leave at least six feet (72 inches / 1.8 meters) clearance on both sides and the front of the Lift, and no obstructions at all at the Rear of the Lift to safely drive Vehicles onto the Runways.
- **Power.** You need an appropriate power source for the Power Unit.
- **Outdoor installations.** Your Lift is approved for **indoor** installation and use **only**.

-
- **Floor.** Only install the Lift on a flat, Concrete floor; do not install on asphalt or any other surface. The surface must be level; do not install if the surface has more than three degrees of slope.

 **WARNING** Installing your Lift on a surface with more than three degrees of slope could lead to injury or even death. Only install the Lift on a level floor. If your floor is not level, consider making the floor level or using a different location.

- **Shimming.** If your Concrete floor is not completely level, you can use the supplied Shims under the bases of the Posts, to a maximum of 0.5 in. / 13 mm, to level the Lift.

To estimate your Shim requirements, use a transit level and targets to check for flatness. Use the provided Shims, as necessary.

NOTICE If shimming beyond 0.5 in. / 13 mm is required, a maximum shim of 2 in. is possible by ordering optional Shim Plates. Contact BendPak at **(800) 253-2363**, select option 7, then 4 to order.

- **Concrete specifications.** Do not install the Lift on cracked or defective concrete. Make sure the concrete is at least 4.25 inches thick, compressive strength of 3,000 PSI minimum, steel reinforced, and cured for a minimum of 28 days.

 **CAUTION** BendPak lifts are supplied with installation instructions and concrete anchors that meet the criteria set by the American National Standard “Automotive Lifts – Safety Requirements for Construction, Testing, and Validation,” ANSI/ALI ALCTV. You are responsible for any special regional structural and/or seismic anchoring requirements specified by any other agencies and/or codes such as the Uniform Building Code (UBC) and/or International Building Code (IBC).

- **Check the concrete floor** to determine if it is a **post-tension slab**. In this case, you must contact the building architect or the local building and safety department before drilling. Using ground penetrating radar may be required to find the tensioned steel.

 **WARNING** Cutting through a tensioned cable can result in injury or death. Do not drill into a post-tension slab unless the building architect confirms you are not going to hit tensioned steel, or you have located it using ground penetrating radar. **If a colored sheath comes up during drilling, stop drilling immediately.**

If the existing concrete floor does not meet the minimum requirements **BendPak strongly recommends consulting a Concrete Specialist early in your planning process for the Lift installation.** The recommendations presented in this manual are generic in nature and cannot cover all situations. A Concrete Specialist will adjust these recommendations to account for national, state, and local building codes as well as local weather conditions, soil composition, base preparation, load bearing, seismic requirements and any other structural concerns that may arise.

Select a Power Post Location

Choose a Power Post location at this point, as its location impacts other aspects of the installation.

You have two options for Power Post location: **Driver-Side Front** or **Passenger-Side Rear**.

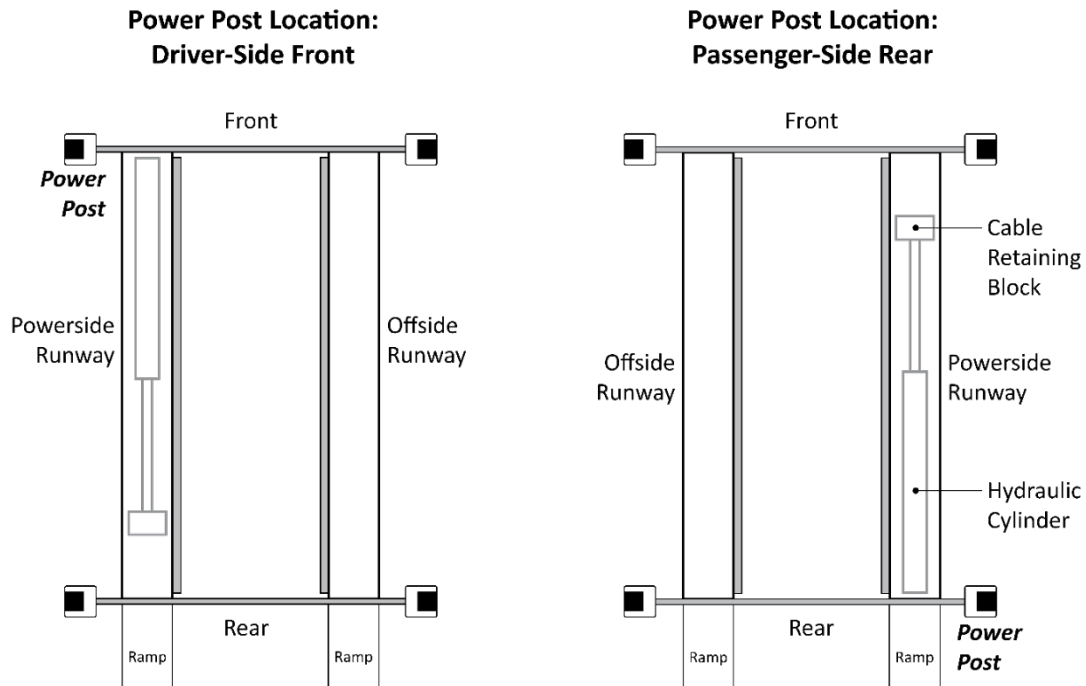

Note: The Power Post location decision has no impact on the Approach direction.

*Power Side Runway (which has the Hydraulic Cylinder under it) **must** be installed next to the Power Post, no matter which Power Post location you choose.*

Most customers choose their Power Post location based on either preference (one option makes more sense for their shop than the other does) or easier access to the power source.

Checking Clearances

For safety purposes, adequate clear space around and above the Lift is **required**. Do not install the lift where people frequent, where vehicles are actively in the approach areas, and/or in-the-path of frequent deliveries.

Check Clearance Above the Vehicle

A minimum of 12-inches above the highest point on the vehicle is required to allow room to raise above the safety lock engagement.

Check Clearances Around the Lift

Side view. Not to scale. Components removed for clarity.

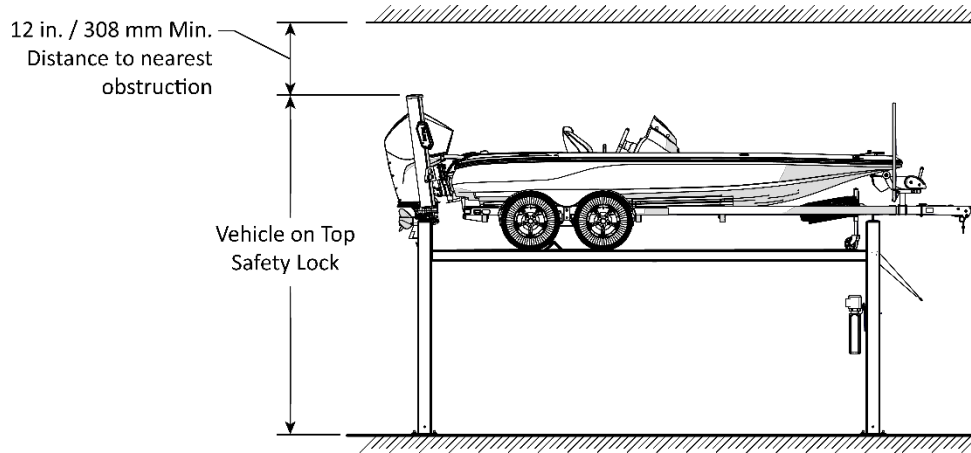

Drawing below is a top view. Not to scale. Not all components shown.

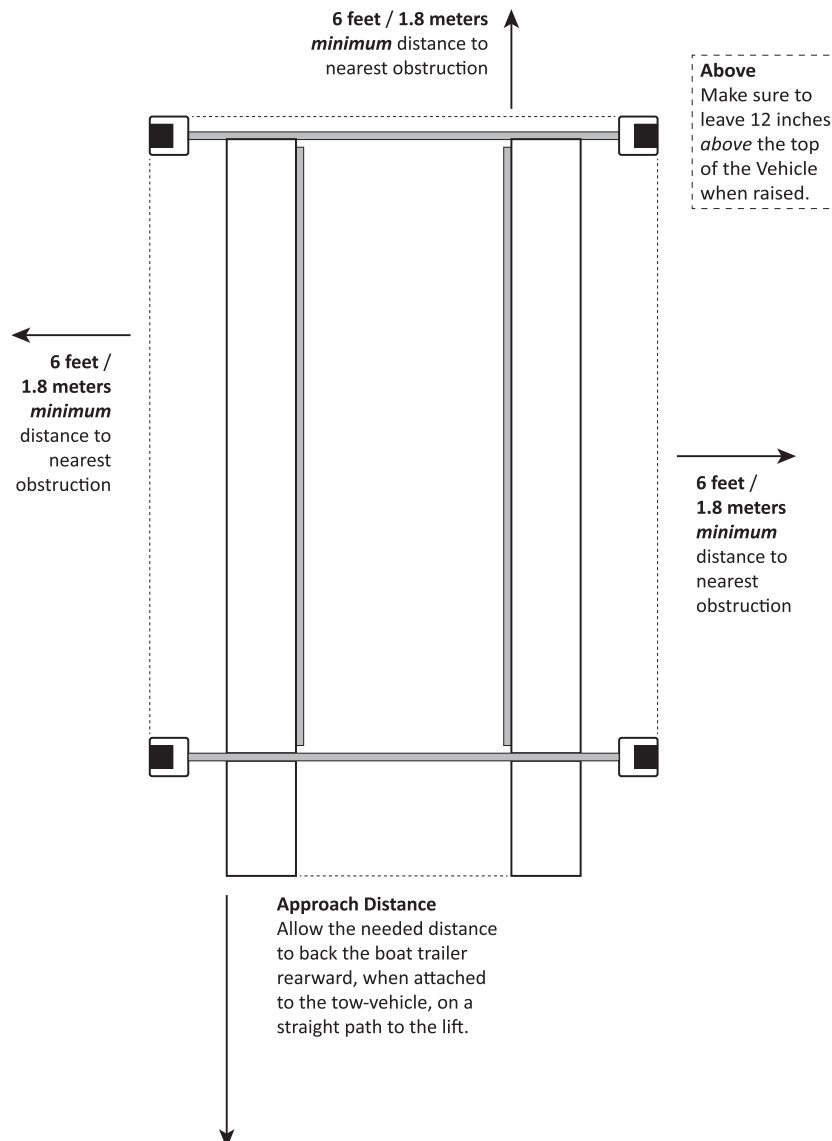

Unloading and Unpacking

Try to have the components of the Lift unloaded near the installation location.

Once the components are unloaded, they are your responsibility to move. As the Lift includes many heavy items, the closer you unload them to the installation location, the better.

CAUTION Some Lift components are very heavy; if handled incorrectly, they can damage materials like tile, sandstone, and brick. Try to handle the Lift components twice: once when delivered and once when moved into position. You must have a Forklift or Shop Crane to move them into position. Use care when moving them.

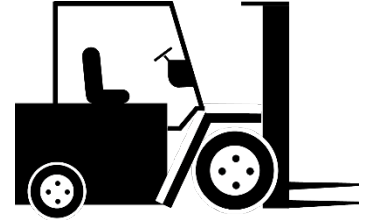

WARNING The Posts and Runways are delivered with stabilizing structures on each end. Be very careful when removing these stabilizing structures; the Posts and Runways can shift or even fall. If they fall on a person, they could cause severe injury.

Create Chalk Line Guides

Create Chalk Line Guides so that the outside edges of all four Post bases fit into the four corners created by the Chalk Line Guides. Refer to **Specifications** to determine the **Overall Width** and **Outside Length** values for your Lift.

Note: Do **not** use the **Overall Length** value; this includes the Ramps, which are not taken into consideration for creating Chalk Line Guides.

Note: Pay careful attention to the **Overall Width** measurement. It is critical to keep this measurement within ± 0.125 in. / 3.2 mm.

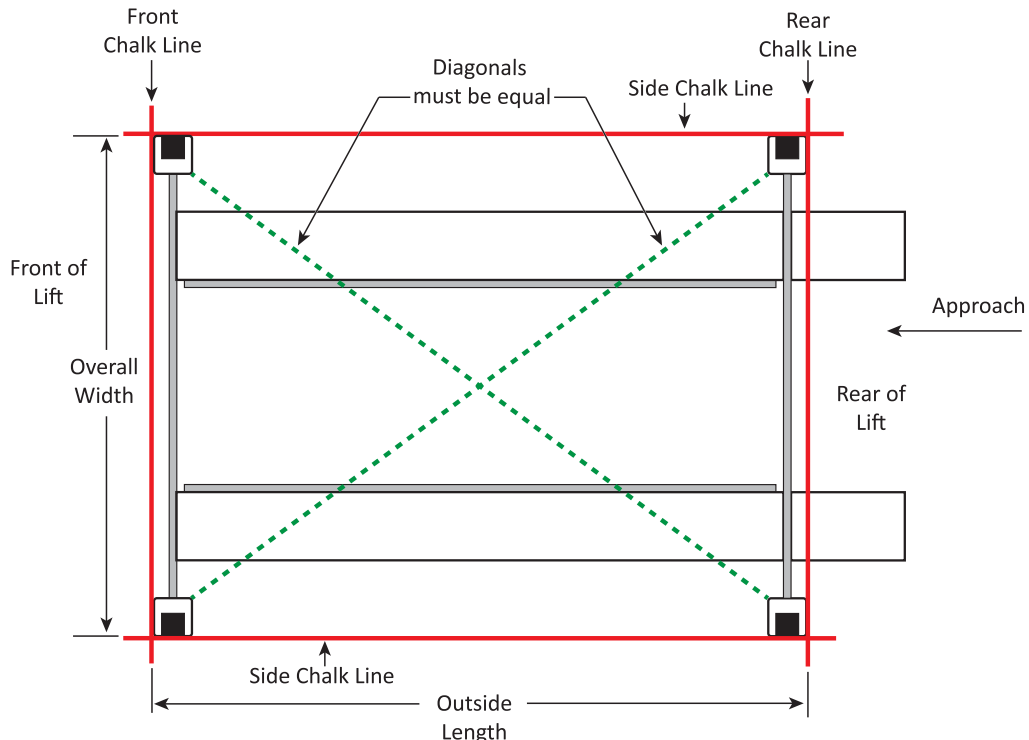

To create Chalk Line Guides:

1. Create the Front Chalk Line where you want the Front of the Lift.
Make the Front Chalk Line longer, by 12 inches on each end, than the **Overall Width** setting.
2. Create the two side Chalk Lines at a 90° angle to the Front Chalk Line and parallel to each other.
Make the side Chalk Lines longer (by 12 inches on each end) than the **Outside Length** setting.
All Chalk Lines **must** be parallel and perpendicular to each other.
Measure to verify that they are parallel.
3. Create the Rear Chalk Line parallel to the Front Chalk Line. Make the Rear Chalk Line longer than the **Overall Width** setting for your Lift model.
The Front and Rear Chalk Lines **must** also be parallel to each other.
Measure to verify that they are parallel.
4. Before moving the Posts into position, measure **diagonally** to verify the two diagonal measurements are the same. **Do not forget to check the diagonals.**
5. When you move the Posts into position, put the outside edges of the bases inside the corners created by the Chalk Line Guides.

Move the Posts into Position

Use a Forklift or Shop Crane to move the four Posts, one at a time, to the inside corners of the Chalk Line Guides.

 **DANGER** The Posts are heavy and awkward; be very careful when handling them. If they fall on a person, they may cause severe injury.

 **WARNING** Prevent injuries! Lifting Hazard! Seek assistance, use appropriate lifting equipment and team lift heavy objects.

Important: Position the Power Post at the location you chose earlier. The other three Posts are placed at the remaining locations.

 **WARNING** Be very careful when walking around the Posts; they are not anchored down at this point, so it is possible to knock them over, which could cause significant injury.

Installing the Crosstubes and Slide Blocks

Your Lift has two Crosstubes; **they are similar, but not the identical:**

- **One Crosstube has Two Large Windows** and must be installed at the Cable Retainer Block end of the Power Side Runway.
- **One Crosstube has Two Small Windows** and must be installed adjacent to the Power Post.

Both Crosstubes are hollow, which allows the Lifting Cables to run through them to the Posts.



Tip

It is possible to install the Crosstubes **incorrectly** in several different ways. Take your time and install it right the first time.

Both Crosstubes **must** be installed so that the Windows open to the **inside** of the Lift.

Important: Your Power Post location impacts Crosstube installation. The Crosstube with two Small Windows **must** be installed next to the Power Post. The location of the Ramps do not come into play when determining where the Crosstubes will be installed.

Crosstubes **must** be installed so that their Windows are on the Power Side Runway, side of the Lift.

The following drawing shows the two Crosstube setups based on Power Post location.

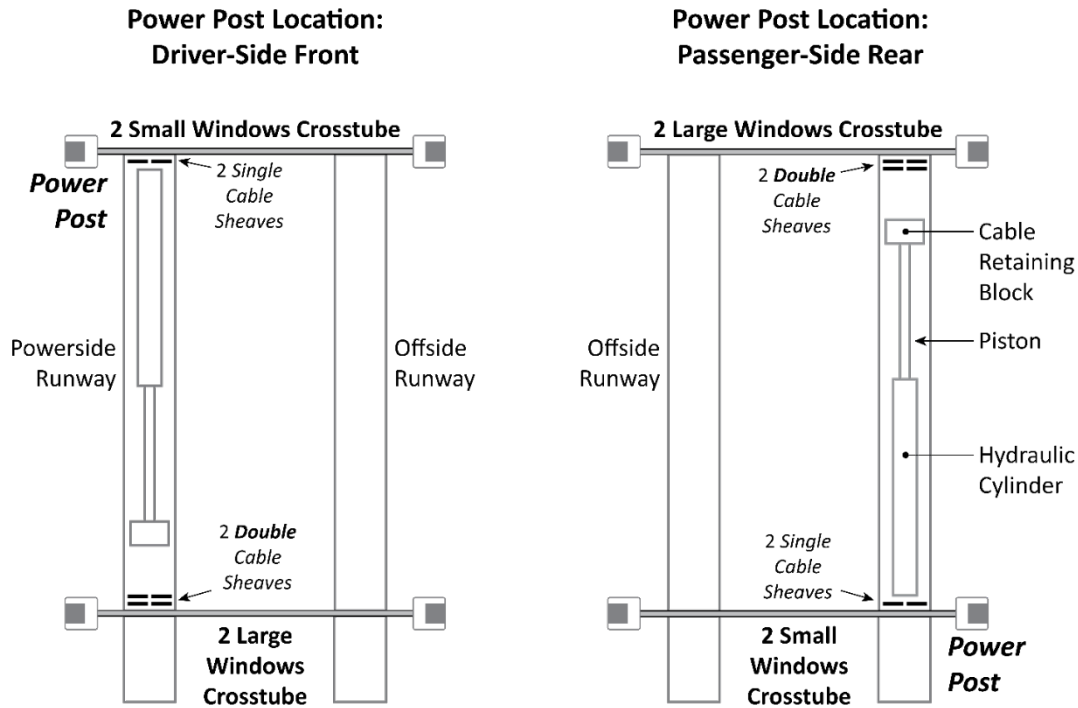

Top view. Drawing not to scale. Components removed for clarity. The location of the Approach Ramps does not change based on Power Post location, but the Power Side Runway and Crosstube locations do. Windows are in the Crosstubes; they are shown here at the ends of the Power Side Runway for clarity.

About Slide Blocks

The Slide Blocks on the corners of the Crosstubes are installed at the factory. If they fall off or do not arrive installed, put them into place so that each pair creates a Slot into which the Ladder for each Post will be installed.

In the drawings below, the drawing on the left shows how two Slide Blocks are put into position; the drawing on the right shows the Slot created by the two Slide Blocks when they are installed. There are two Slots per Crosstube Gusset, one at the top and one at the bottom. The Ladder **must** go through **both** Slots.

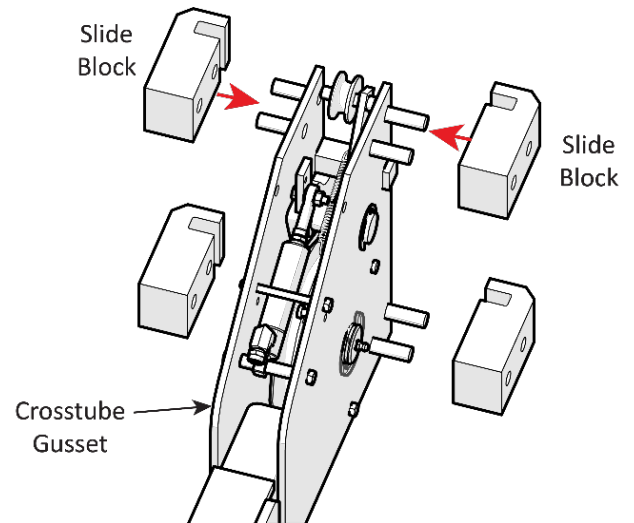

Important: It is easy to see the top Slot created by the Slide Blocks. It is difficult to see the bottom Slot, but it is **required** that the Ladder go through **both** Slots.

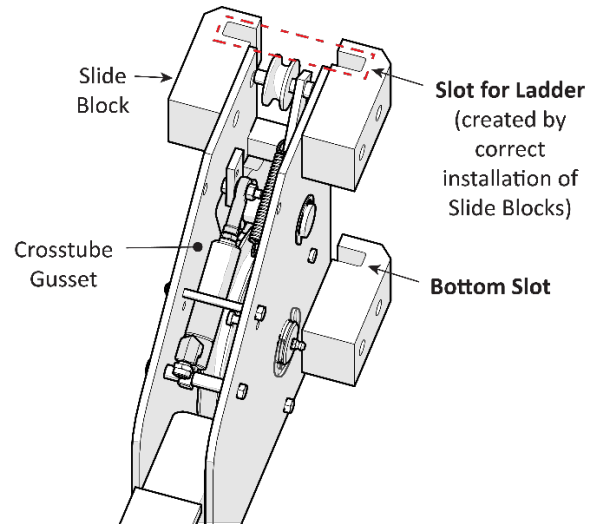

To install the Crosstubes:

1. Orient the Crosstubes in their **required** locations:
 - The Crosstube with two Large Windows must be on the Cable Retainer Block end of the Power Side Runway with both Windows facing the inside of the Lift.
 - The Crosstube with two Small Windows must be located next to the Power Post with both Windows facing the inside of the Lift.

Both Windows *must* be on the ends of the Power Side Runway and facing the inside of the Lift.

2. Lean over the **two** Posts at one end of the Lift and rest the open end on Sawhorses or place them on the ground.
3. Orient, then slide the Crosstube into the open ends of the two posts and slide all the way to the bottom of the posts.
4. Perform Step 2 for the second Crosstube and the remaining two Posts.

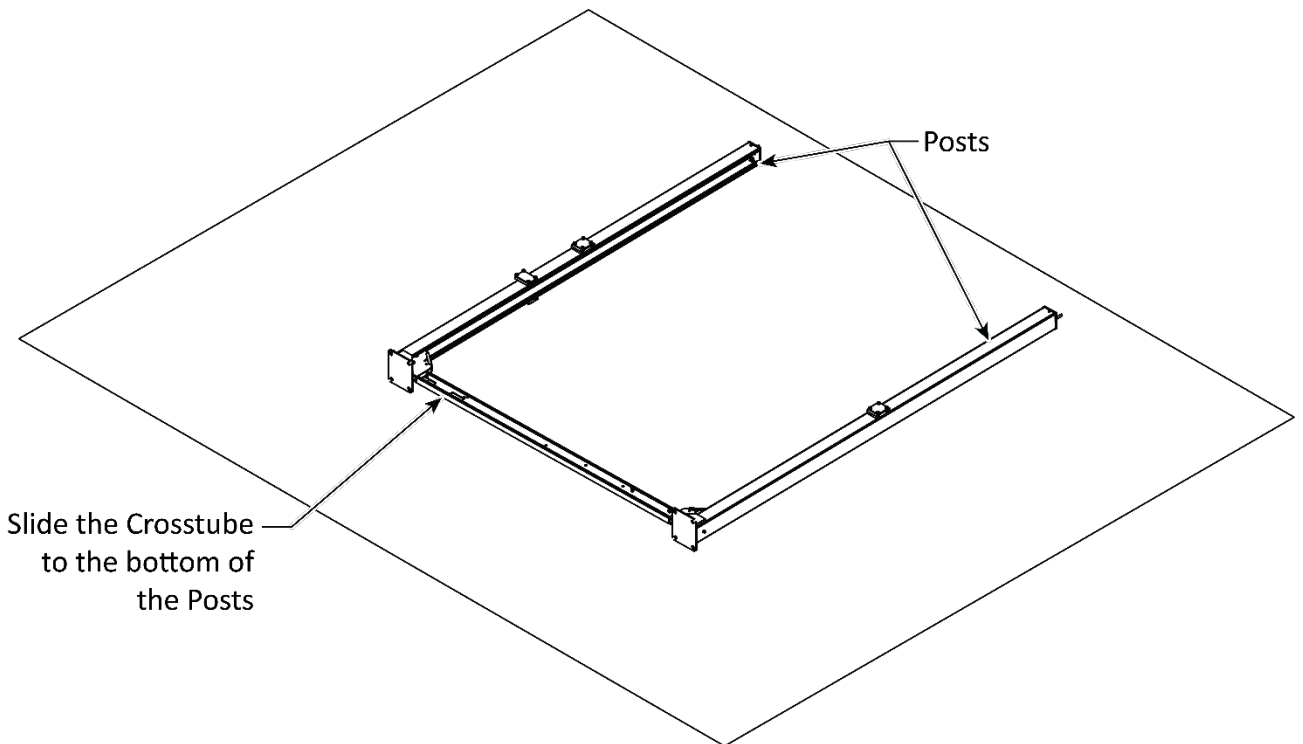

About Safety Locks

Safety Locks hold the Runways in place. Once engaged, Safety Locks hold the Runways in place, even if the power is out or the Hydraulic Hoses break or leak.

Important: Simply raising the Runways does not **engage** them on the Primary Safety Locks. You must back the Runways down onto the Safety Locks to engage them.

⚠ WARNING Safety Locks are dependent on correct installation of the Safety Ladders. Pay careful attention when installing the Ladders, thus ensuring correct operation of the Safety Locks on your Lift.

The Ladders are steel assemblies with openings spaced every four inches. As you raise the Runways, the Primary Safety Locks move into the holes in the Ladder. When you move the Runways back down after passing a Safety Lock hole, the Safety Lock engages. Once they are engaged, Safety Locks stay engaged until you lower the Runways.

⚠ WARNING Always leave the Runways either fully lowered or engaged on the Primary Safety Locks. When you engage the Safety Locks at a desired height, check to make sure that all four Safety Locks are engaged at the same height.

To lower the Runways, raise them a few inches (to move them off the Primary Safety Locks), then ***press and hold down*** the Pushbutton Air Valve. While you hold down the pushbutton, the Primary Safety Locks are moved away from the Safety Lock holes in the Ladders; they are prevented from engaging, which allows the Runways to be lowered.

Your Lift has a second, independent Safety Lock system called the Slack Safety:

- **Primary Safety Locks.** Located at the ends of each of the four Crosstubes, the Primary Safety Locks hold the Runways in place *once they are engaged*. Once engaged, Primary Safety Locks hold the Runways in place, even if the power is out or the Hydraulic Hoses break or leak.
- **Slack Safety Locks.** Also located at the ends of each of the four Crosstubes, the Slack Safety Locks are a backup system in case any of the four Lifting Cables break (which is a rare occurrence). During normal operation, the Lifting Cables prevent the Slack Safety Locks from engaging, but if a Lifting Cable breaks while the Lift is not engaged on its Primary Safety Locks, the Slack Safety Lock next to the broken Lifting Cable immediately engages at the next Safety Lock position in the Ladder.

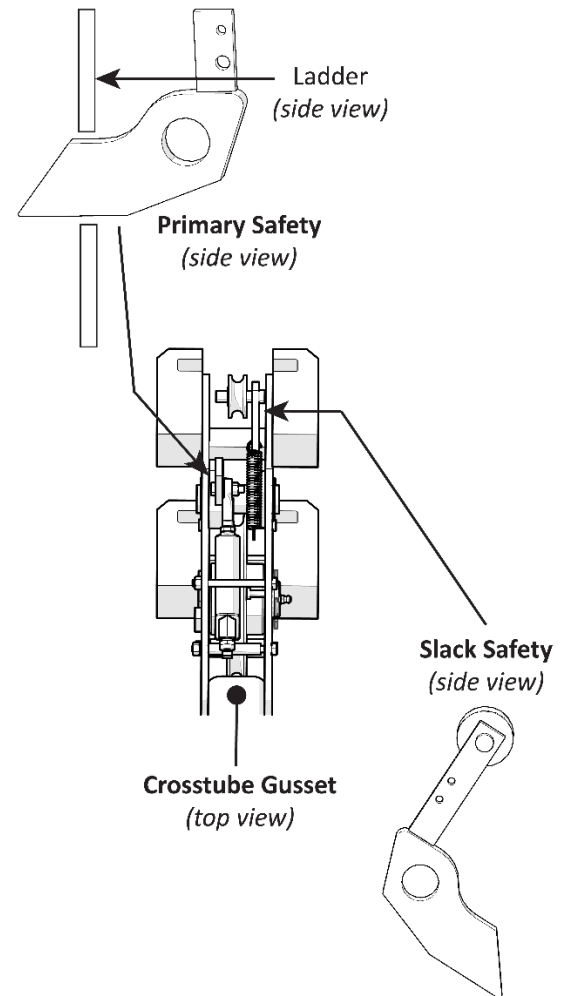

Install the Ladders and Top Caps

Your Lift has four Safety Ladders (one per Post); each Ladder is installed on the inside back of a Post. Ladders are secured at the top and the bottom of the Post. All four Ladders are identical.

It is **not** necessary to slide the Ladders in from the very top of the Post.

The Top Caps secure the Ladder at the top of each Post and hold the ends of the Lifting Cables.

Note: It is much easier to secure the bottom of the Ladders once the Crosstubes have been raised, so that portion of installing the Ladders is described in **Securing the Ladders**.

Each Ladder has a Bolt Hole at the bottom and a Threaded Bolt at the top.

⚠ WARNING Make sure to install the Ladders correctly. If they are not installed correctly, the Safety Locks on your Lift may not hold the weight of a Vehicle, putting anyone under and around the Lift in danger.

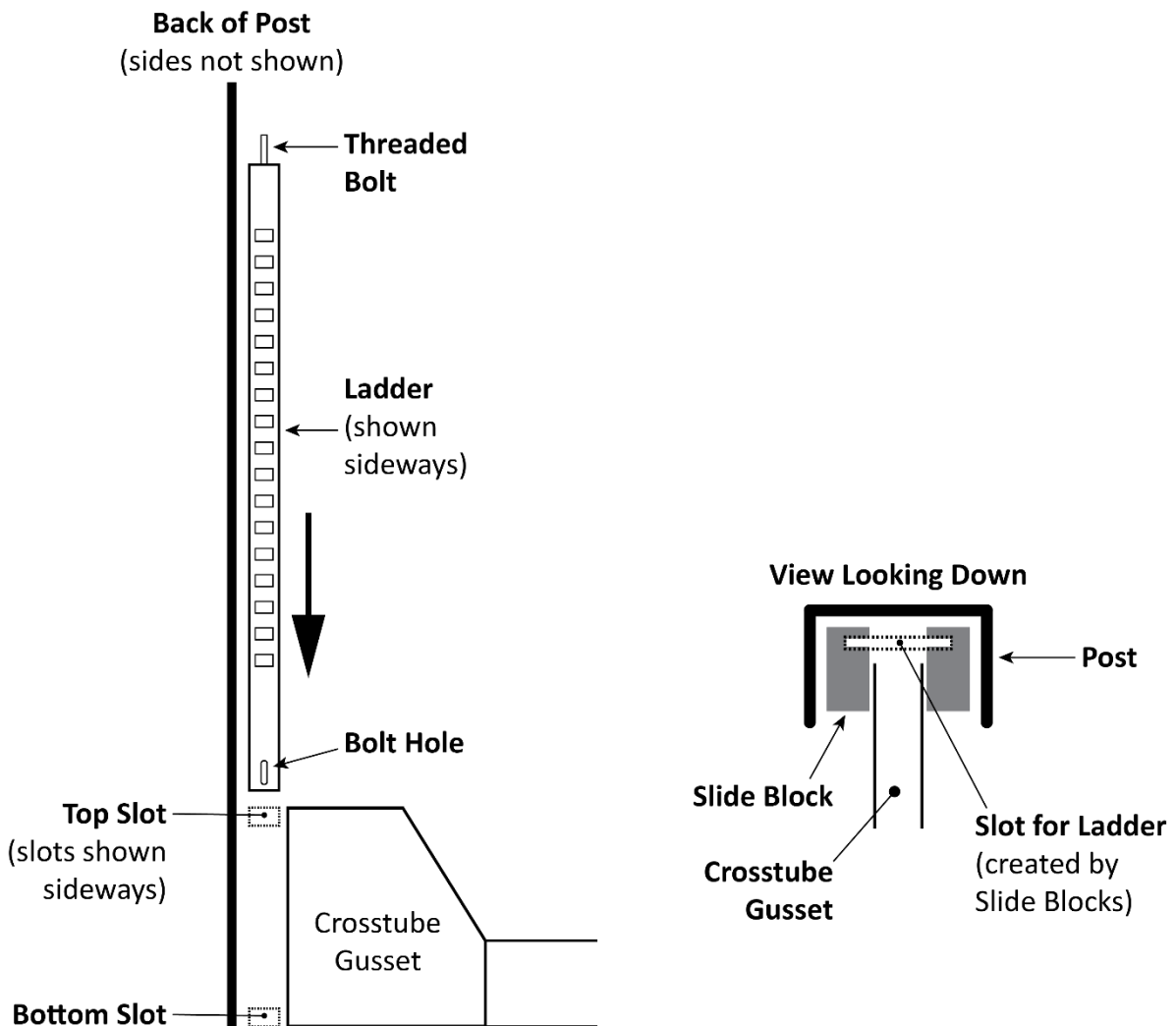

Not to scale. Components removed for clarity. Front and side views combined. Make sure to install each Ladder through **both Slots** on each Crosstube Gusset.

To install the Ladders and the Top Cap:

1. Retrieve a Ladder and slide it into the back of a Post, with the Bolt Hole end at the bottom.

⚠ WARNING Verify all four Ladders run through **both** Slots created by the Slide Blocks. Verify the Ladder runs through **both** Slots. There is a Slot created at the top and another at the bottom of each Crosstube Gusset.

Important: It is easy to see the top Slot created by the Slide Blocks. It is difficult to see the bottom Slot, but it is **required** that the Ladder runs through *both* Slots.

If the Ladder misses a Slot or the Slide Blocks were not installed correctly, your Safety Locks will **not** function correctly.

2. Install the other three Ladders in the same manner.
3. **Moving to the top of the Ladders**, move the Stop Nut half of the way down towards the top of the Ladder.

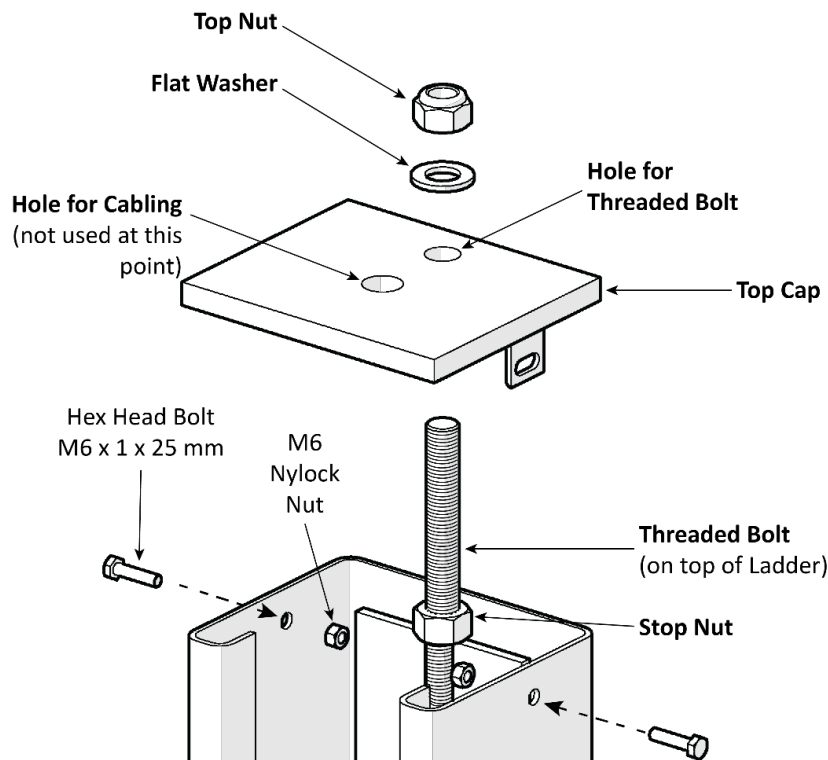

4. Install a Top Cap into the top of the Post: insert the Threaded Bolt on the top of the Ladder through the appropriate hole, put the tabs on the side of the Top Cap inside the Post, and secure the Top Cap on both sides with one Hex Head Bolt and one Nyloc Nut per side.
5. Once the Top Cap is secure, move the Stop Nut up until it contacts the underside of the Top Cap, then add a Flat Washer and Nyloc Nut to the top of the Top Cap and tighten. Hand tighten only.

IMPORTANT: About one inch of thread should extend above the top of the Top Nut and the safety Ladder should be at least 1/2-inch off the base of the column.

Note: The remaining hole in the middle of the Top Cap is for the Lifting Cable, installed later.

6. Install the other three Top Caps the same manner.

Raise the Posts and Crosstubes

Using appropriate lifting equipment, raise the Posts and Crosstubes. Have **at least two people** work together to stand up the Posts and Crosstubes.

To Raise the Posts and Crosstubes:

1. Verify the Crosstubes are all the way to the bottom of the Lift Posts.
2. Move the Posts and Crosstubes so that they are positioned inside the chalk lines created to position the Lift.
3. Using appropriate Lifting equipment, raise the Lift Posts to their upright position.

⚠ WARNING The Posts and Crosstubes are heavy and awkward to handle. Personnel installing the Lift should be experienced in lifting and rigging heavy materials safely. Improper rigging and lifting of loads could result in severe injury to personnel and/or damage to the equipment.

⚠ WARNING Be very careful when moving or working around the Posts; they are not anchored at this point, so it is possible to knock them over, which could cause severe injury and or damage.

Do not anchor the Posts at this point.

HD-7500PBX Shown below.

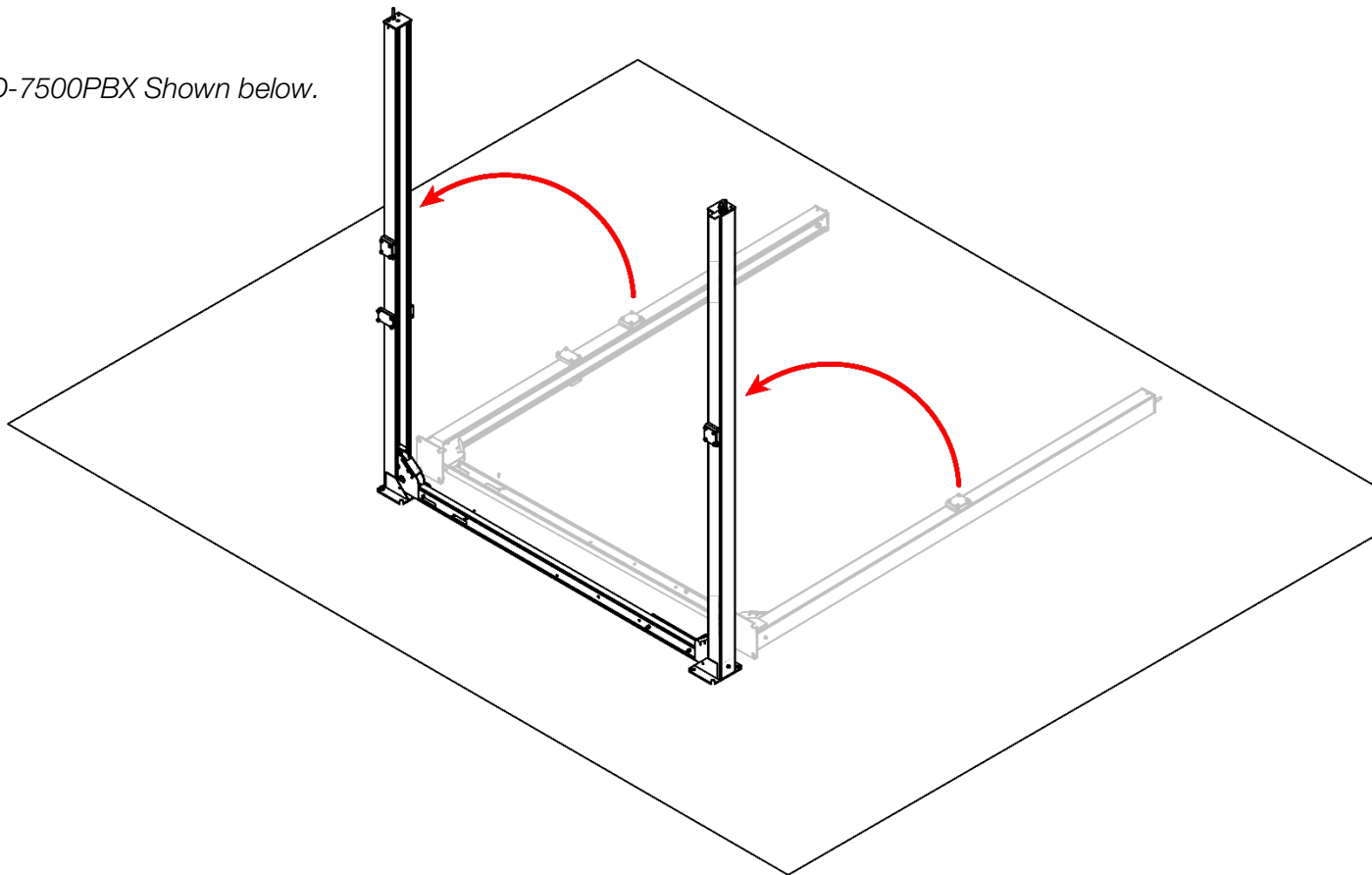

Install the Stiffeners HD-7500PBX Only

Stiffeners are required on the HD-7500PBX *only*.

1. Retrieve two Stiffeners (5601411) and two Top Stiffeners (5601409).
2. Retrieve from the Parts Box:
 - 20 - M12 x 35 mm Hex Head Bolts
 - 20 - M12 Flat Washers
 - 20 - M12 Hex Nuts
3. Raise the Stiffeners into position.
4. Bolt both the Stiffener and the Top Stiffener to each post. Refer to the figures below.

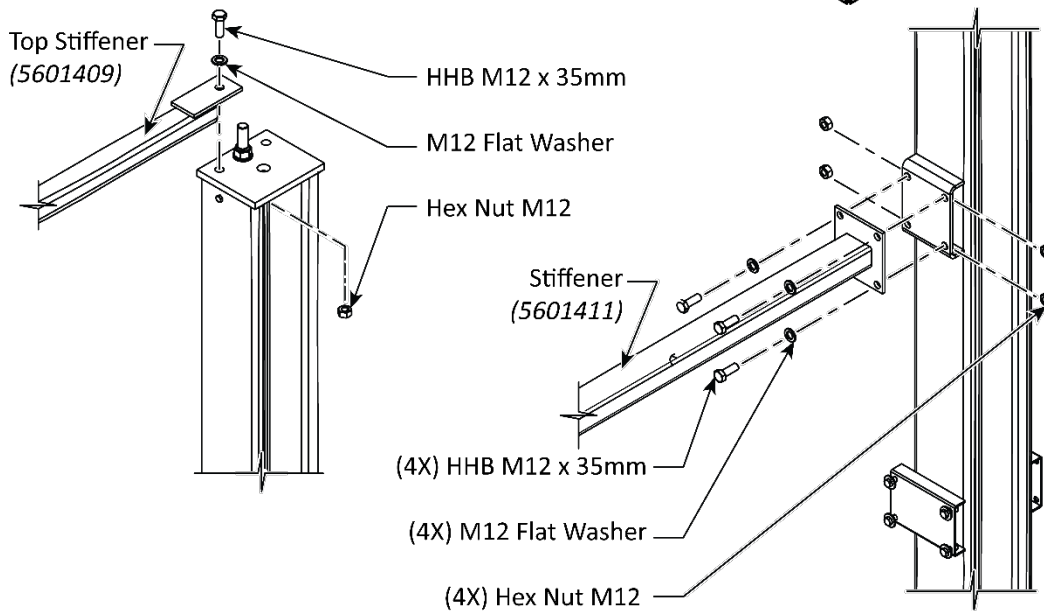
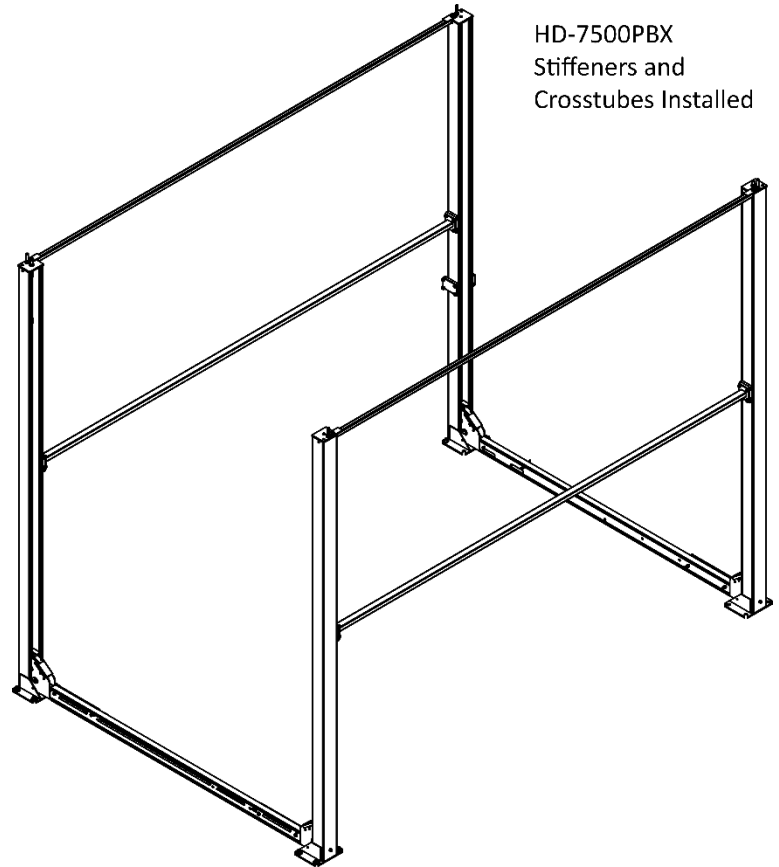

To raise the Crosstubes (all models):

1. Using a Forklift or Shop Crane, **carefully** raise each Crosstube.

Raise the Crosstubes at least five feet off the ground, to provide enough room to work under them when routing the Lifting Cables, Return Lines, Air Lines, and Hydraulic Hoses.

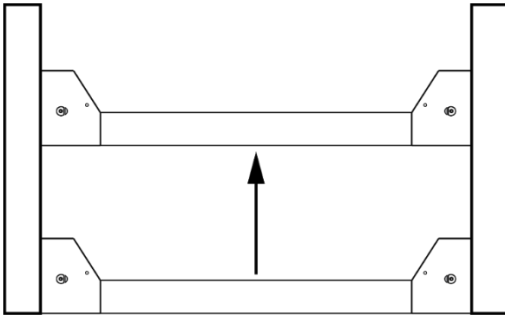

Important: The Slack Safety Locks will automatically engage when you raise the Crosstubes. They **cannot** be engaged to continue with the installation.

2. To disengage the Slack Safety Locks after raising a Crosstube: raise and hold one end of a Crosstube until the Primary and Slack Safety Locks are disengaged, push, and hold the Slack Safety Roller in toward the Safety Ladder (this moves the Slack Safety Lock so it cannot engage), lower the end of the Crosstube, then release the Slack Safety Roller.

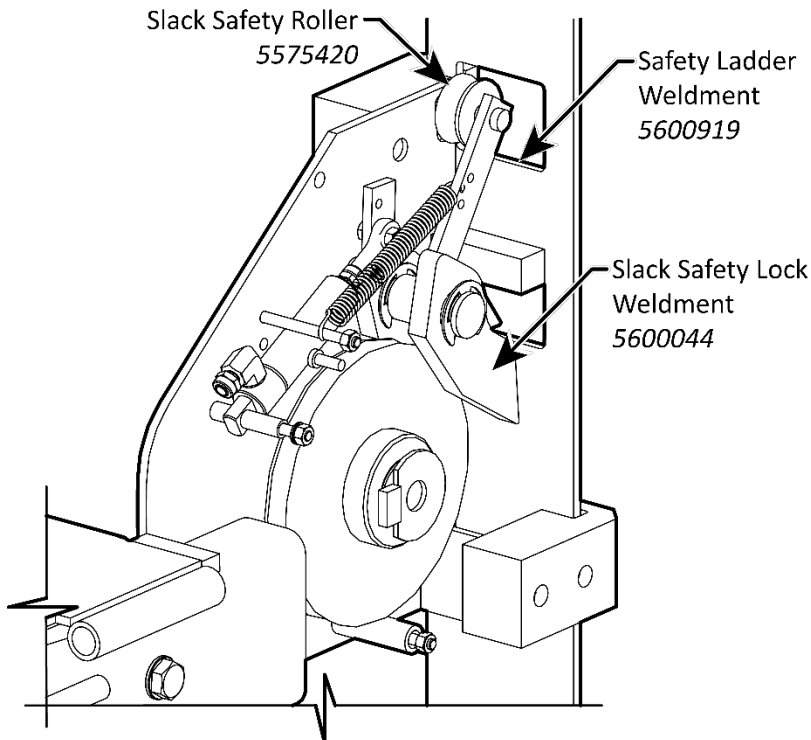

Figure not to scale. Components removed for clarity.

The Primary Safety Lock is now engaged, but the Slack Safety Lock is *not*.

3. Disengage the other three Slack Safety Locks as completed in Step 2.

- Once both Crosstubes are raised, **all four Primary Safety Locks are engaged**, and all four Slack Safety Locks have been **disengaged**, you can continue with the installation.

Securing the Safety Ladders

Because it is much easier to secure the Ladders at the bottom of each Post **after** the Crosstubes have been raised, that procedure is described here.

Note: The following procedure assumes that the Ladders are in place and secured at the top. If this is **not** the case, return to **Installing the Ladders and Top Cap**.

To secure the Ladders:

- Locate a Bolt, Washer, Spacer, second Washer, and Nut for each Ladder. Refer to the figure below.

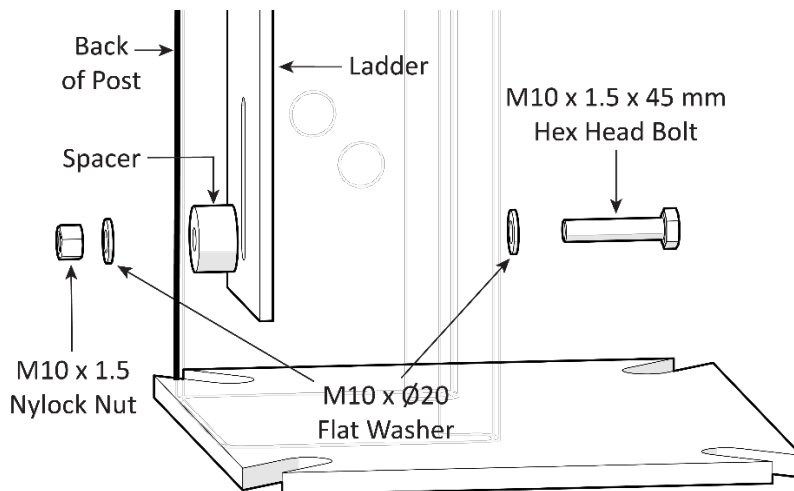

Side View. Not drawn to scale. Not all components are shown.

- Put a Washer next to the Bolt head, then insert the Bolt just through the elongated hole near the bottom of the Ladder.
- Put the Spacer into position between the Ladder and the back of the Post.
- Push the Bolt through the Spacer and then through the back of the Post.
- Take the second Washer and the Nut and install them on the end of the Bolt; secure the Nut.
- Perform the same procedure to secure the other three Ladders on the Lift.

Note: Do not securely tighten the Nut above the Top Cap at this point. The Top Nut and the Stop Nut will be used later to level the Lift. They can be securely tightened after you do the final leveling of the Lift; refer to **Final Leveling** for additional information.

⚠ WARNING Make sure all four Ladders are correctly installed and secured. If not, the Lift may not be able to hold a Vehicle, which is a danger to anyone under the Vehicle or around it.

- Verify the Primary Safety Locks are engaged.

⚠ DANGER Do not continue with the installation until you have visually confirmed that **all four** Primary Safety Locks are engaged. If they are not engaged, the Crosstubes and

runways could move or fall, possibly causing severe personal injury (even death) or product damage.

Remove the Sheaves

To route the Lifting Cables, the Cable Sheaves on the underside of the Power Side Runway must be removed, the two Side Sheaves, and the four Gusset Sheaves and their Lock Pins.

HD-7500PBX incorporates a pull box and anchors in place of the cable retaining block. Remove all Cable Sheaves from under the Powerside Runway including the Pull Box and the Direction Sheaves.

Important When you remove the Sheaves, **keep all the components grouped together**. They will be reinstalled at the same locations, using the same components.

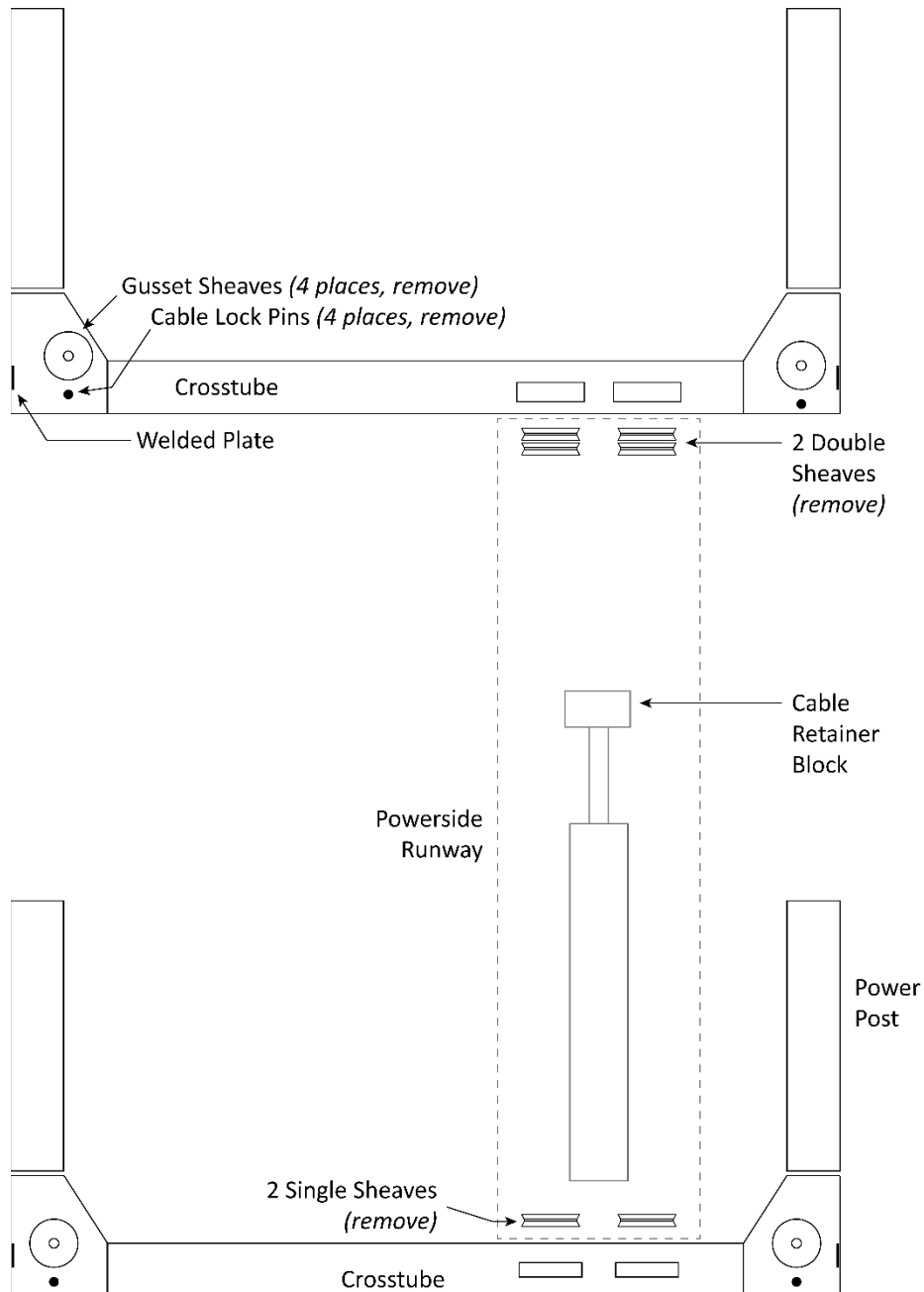

Install the Runways

Your Lift has two Runways:

- **Power Side Runway:** The Lift's Hydraulic Cylinder is mounted underneath it and is bolted into position. Includes openings (on the Cylinder end) that allow the Hydraulic Hose, Air Lines, and Return Line to be routed to the Power Unit. Lifting Cable routing terminates under the Power Side Runway.
- **Offside Runway:** Is bolted into position. Does not have a Hydraulic Cylinder under it, nor are there any Lifting Cables under it. The Off side Runway may be installed in a narrow or wide position.

Orient the two Runways as follows:

- Utility Rails face the inside of the Lift.
- The Power Side Runway must be positioned next to the Power Unit on the Power Post.
- There is also a ≈ 1.5 in. diameter hole in the outside of the Power Side Runway near the Power Post. There are other holes in the Runways, but they are smaller and used with accessories only.

The Approach Ramp locations do not change based on Power Post location, but the location and orientation of the Power Side Runway does.

The following drawing shows the correct orientation of the Runways for both Power Post locations.

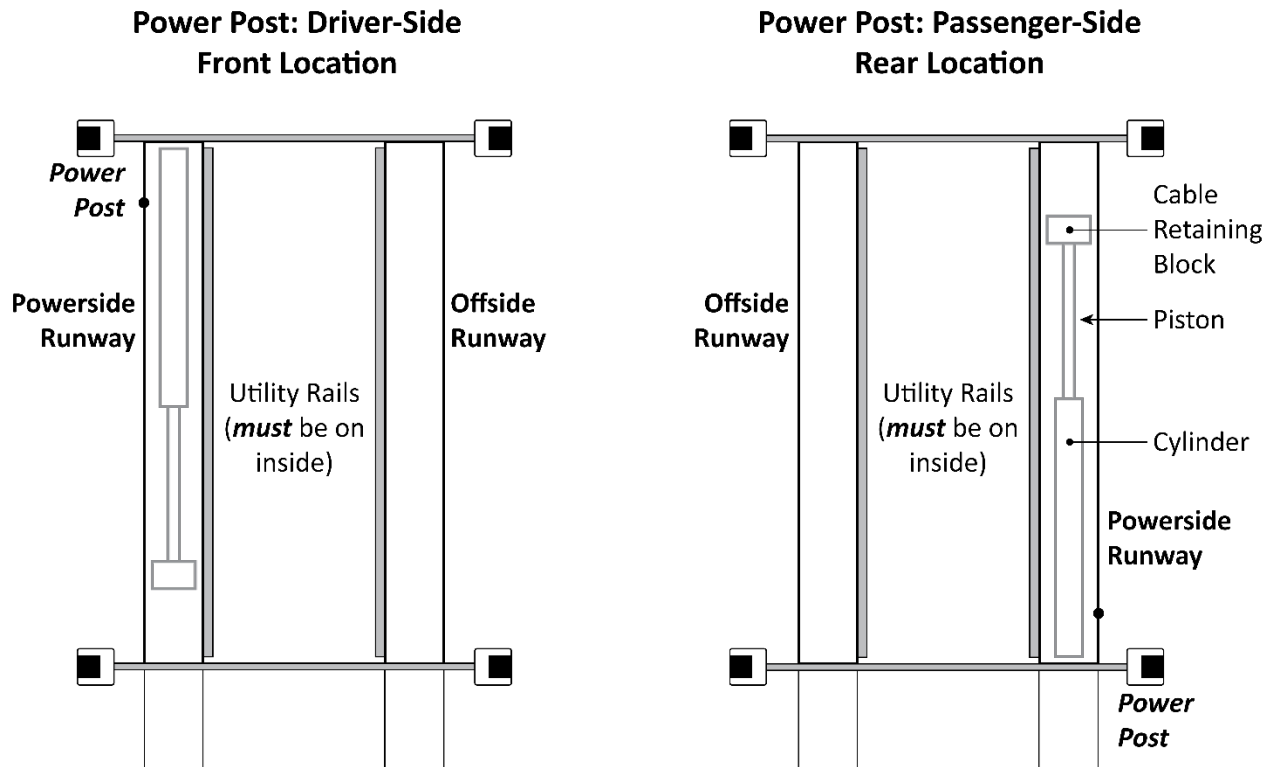

Not to scale. Not all components shown. Tops of Runways not shown.

Use a Forklift or Shop Crane to raise the Runways and move them into position.

⚠ WARNING Pay close attention when moving the Runways into position; they are heavy and long, and could shift position or fall, potentially causing serious injury and damage to equipment.

To install the Runways:

1. Correctly orient the Power Side Runway and the Offside Runway.
See the previous page for more information.
2. On the underside of the Power Side Runway, verify the Sheaves have been removed.
3. Use a Forklift or Shop Crane to pick up the Power Side Runway and move it into place on the Power Side of the Lift.

Make sure the Utility Rail is on the inside.

4. Bolt the Power Side Runway into place, two Bolts on each end going into the Crosstubes.
5. Using a Forklift or Shop Crane, pick up the Offside Runway and move it into place.

Make sure the Utility Rail is faces inside the Lift.

The following drawing shows the Offside Runway being installed in the Wide Setting.

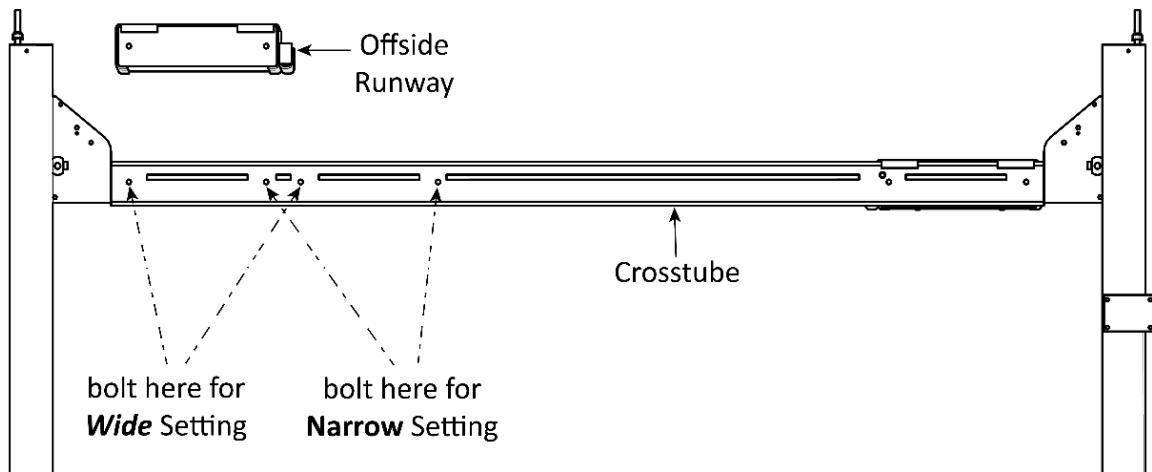

6. Bolt the Offside Runway into place.
7. Make sure the Primary Safety Locks are engaged.

⚠ WARNING Do not continue with the installation until you have visually confirmed that all four Primary Safety Locks are engaged. If they are not engaged, the Runways could move or fall, possibly causing personal injury (or death), or product damage.

Install the First End of the Flex Tube

The Flex Tube is a flexible, black tube that attaches to an opening on the Power Side Runway at one end and to the bottom of the Flex Tube Bracket Plate (near the Power Unit) on the other end.

The Flex Tube consolidates and protects three lines that exit the Power Side Runway on their way to the Power Unit: the Return Line, the Air Line, and the Hydraulic Hose.

The following drawing shows the Flex Tube.

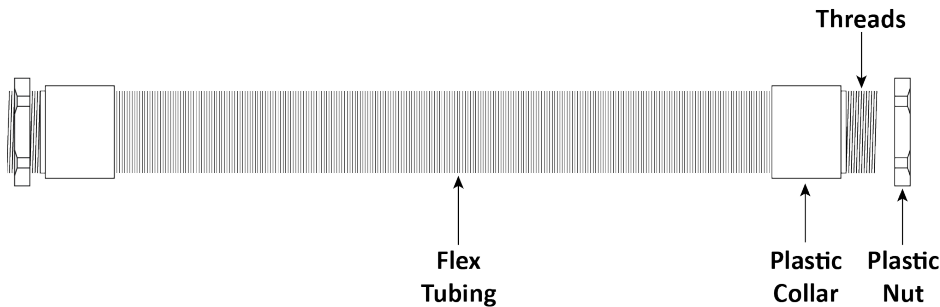

Not to scale. Not all components shown.

To install the Flex Tube to the Power Side Runway:

1. Install one Connector on the Power side Platform opening near the Power Unit and secure. Refer to the figure on the right.
2. Holding the Flex Tube by the Plastic Collar, put the Threads on the end of the Flex Tube through the hole on the side of the Power Side Runway.

The Threads go into the hole until they are accessible from the inside, the rest of the Flex Tube stays outside.

3. On the inside of the Power Side Runway, screw the Plastic Nut back onto the Threads of the Flex Tube and tighten it.
4. Measure, mark, then cut the Flex Tube refer to the table below:

Lift Model	Flex Tube Length (±1 in. / 25 mm)
HD-7500BLX	52 in. / 1320 mm
HD-75BXT	52 in. / 1320 mm
HD-7500PBX	96 in. 2440 mm

5. Install the second Connector on the open end of the Flex Tube.
6. Let the free end of the Flex Tube hang in place for the moment.

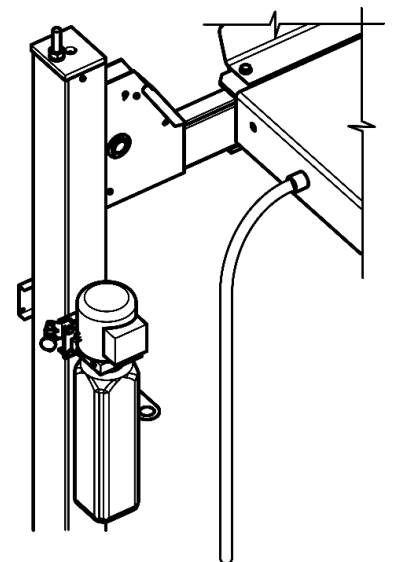
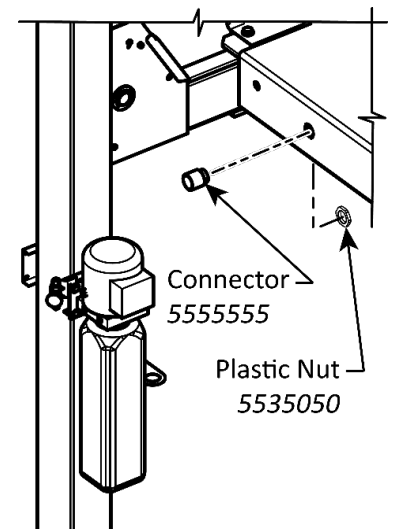

Extend the Piston

Before routing the Lifting Cables, extend the Piston on the Hydraulic Cylinder.

To extend the Piston:

1. Remove the Shipping Plug from the Return Line Port on the Hydraulic Cylinder.
The Return Line Port is on the Cylinder end closest to where the Power Unit will be installed.
2. Check the pressure port and remove the plug if one is present.
3. Attach an air pressure source to the Return Line Port and use the air pressure to extend the Hydraulic Cylinder's Piston; **do not exceed 50 psi.**
4. If the Cylinder does not move, stop using air pressure; instead, use a pulling device (such as a Come-Along) to extend the Piston. Be careful not to damage the Piston.
5. Reinstall the Shipping Plug onto the Return Line Port.

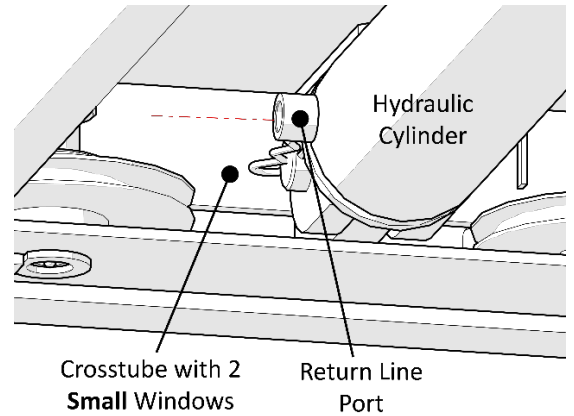

Route the Lifting Cables HD-7500BLX / HD-75BXT Only

Review the figure below providing an overview of the cable routing. For HD-7500PBX Cable routing see [Route the Lifting Cables HD-7500PBX](#) View this manual in color at www.bendpak.com/car-lifts/four-post-lifts/

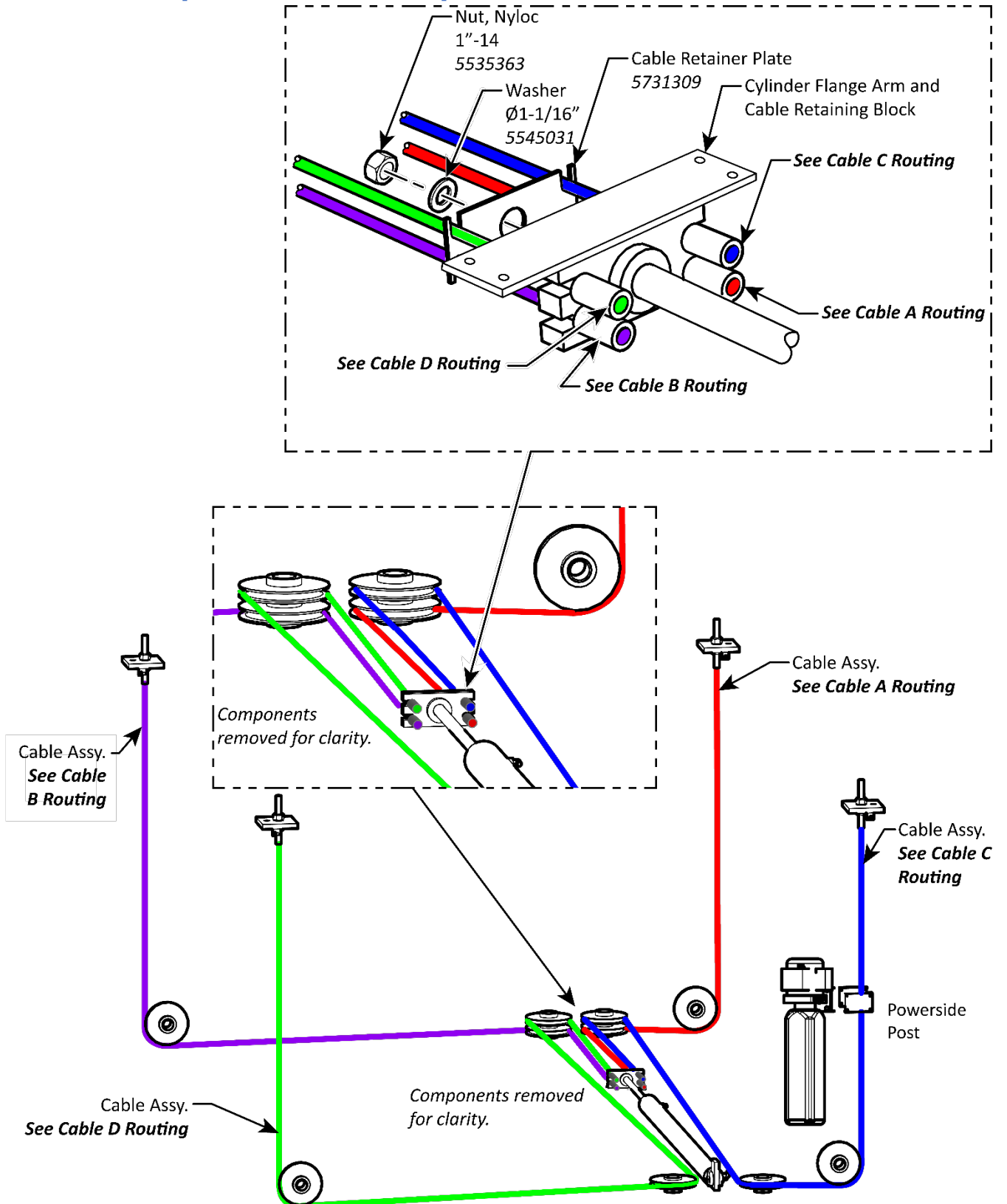

To Route Lifting Cables A and C HD-750BLX & HD-75BXT:

Review the following Cable List and identify each cable before beginning.

HD-750BLX			HD-75BXT	
Cable	Description	P/N	Description	P/N
A	Ø10 x 3,228 mm	5595351	Ø10 x 3,228 mm	5595351
B	Ø10 x 5,471 mm	5595191	Ø10 x 5,471 mm	5595191
C	Ø10 x 7,960 mm	5595348	Ø10 x 8,570 mm	5595710
D	Ø10 x 10,220 mm	5595349	Ø10 x 10,830 mm	5595711

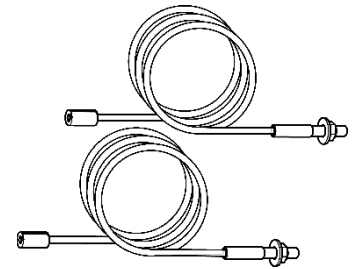

1. **Starting with Lifting Cable A**, move the entire Cable to just under the Large Window it travels through, near the bottom of Post A; verify you have the correct Lifting Cable.
2. Remove the Nut and Washer from the Threaded End (keep it nearby, you will need it soon).
3. Route the Threaded End of Lifting Cable A into its Large Window on the Crosstube, push it towards Post A, and then pull the Threaded End out of the Crosstube at the bottom of the Gusset.

⚠ DANGER When routing the Cables through the Crosstubes verify the cables run below the platform mounting bolts in the Crosstubes. Severe injury or product damage could occur if cables are routed incorrectly.

4. Route the Threaded End of Lifting Cable A **under** where the Gusset Sheave will be installed, then route it up towards the top of the Post past the top of the Crosstube Gusset.

Important: When routing a Lifting Cable in its Post, it must be routed **under** where the Gusset Sheave will be positioned then, when the Cable heads up toward the top of the Post, it **must** run between the Gusset Sheave and the Slack Safety Sheave.

Important: Before re-installing any Sheave, lubricate the Pin and Bearing using a liberal amount of Red Lithium Grease.

5. With the Lifting Cable in place, reinstall the Gusset Sheave and the Cable Lock Pin in Post A.
6. Push the Threaded End of Lifting Cable A up to and through the Top Cap (at the top of the Post) and **hand tighten** until at least 2-3 threads are above the Nut and Washer removed earlier.

Hand tighten the Nut at this point so that there is a little movement in the cabling. All four nuts will be tightened during the leveling procedure.

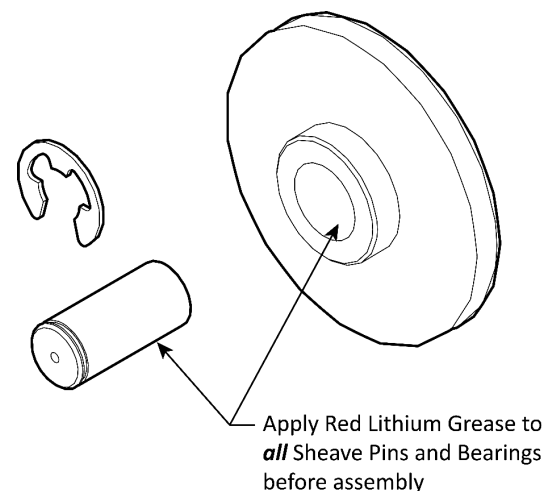
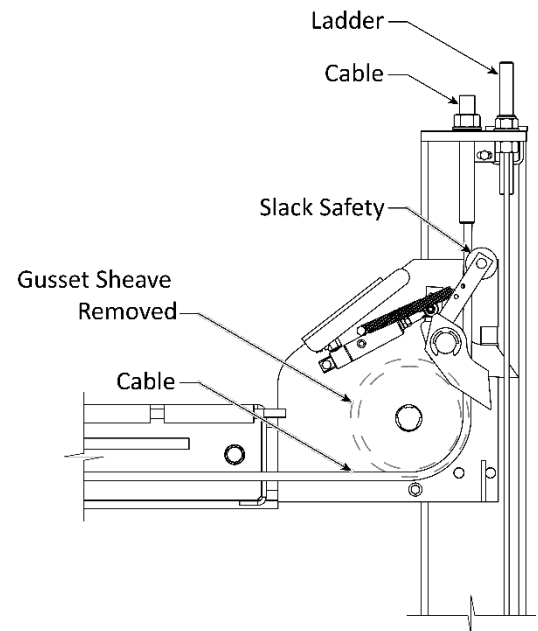

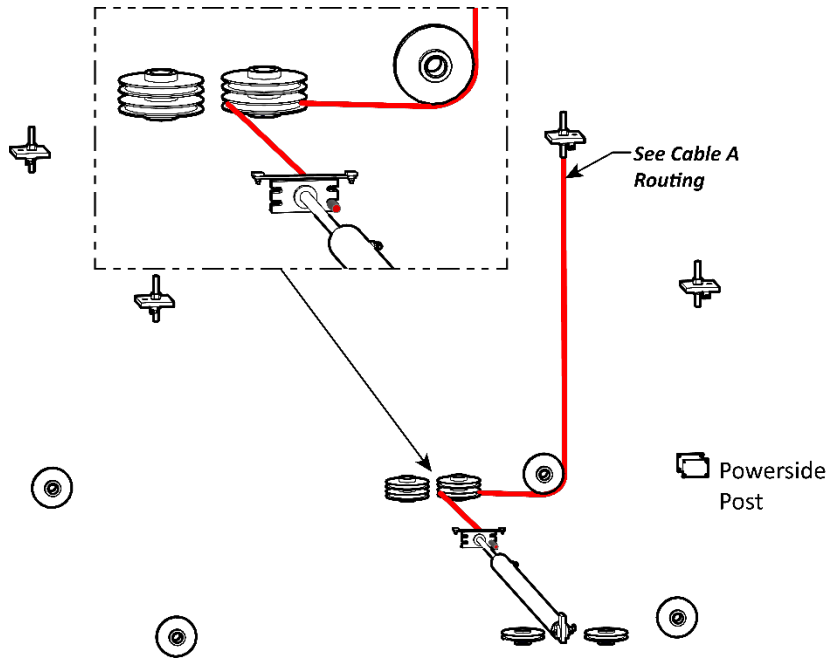

Components removed for clarity. Not to scale.

7. **Switching to Lifting Cable C**, repeat Steps 1 through 7 for Lifting Cable C, starting at the Small Window near the bottom of Post C (the Power Post).
8. Reinstall the Cable Sheave and then verify Lifting Cable C is correctly positioned in the Cable Sheave in the Small Window.
9. Under the Power Side Runway, move the rest of Lifting Cable C back towards the Crosstube with Large Windows.
10. Push Lifting Cables A and C into the Large Window where the Twin Cable Sheave will be installed and pull the Button ends towards the Cable Retainer.
11. With the Cables in place in the Large Window, reinstall the Twin Cable Sheave; make sure Lifting Cable A is set in the Bottom Cable Sheave, and Cable C is in the top Sheave.

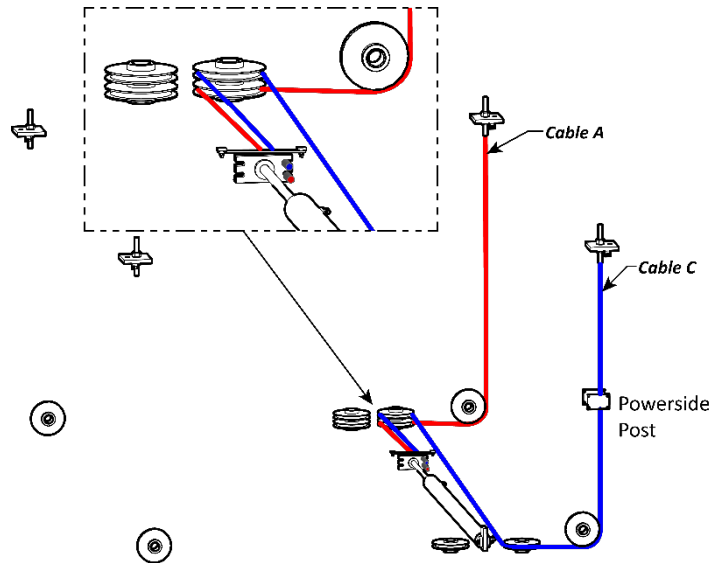

Components removed for clarity. Not to scale.

- Near the Hydraulic Cylinder, loosen the Retaining Plate enough to provide room to slip the Button End of each Cable into its location on the Retainer Block.

Do not remove the Retaining Plate. Instead, loosen the Retaining Plate enough to slip the Button End of each Lifting Cable into place.

- Pull the Button Ends of Lifting Cables A and C back towards the middle of the Runway, past the Retaining Plate, and into its slot on the Cable Retaining Block.

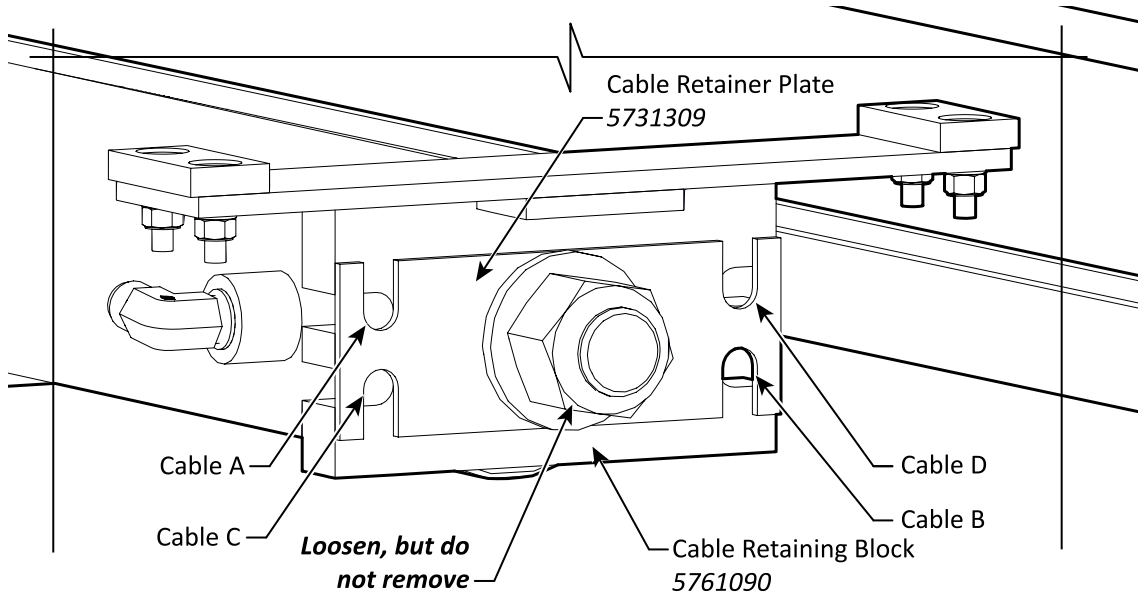

Not to scale. Components removed for clarity.

Note: Routing Lifting Cables B and D is the same process as routing Lifting Cables A and C, just to the other two Posts and using a different set of Sheaves. Refer to the drawings in the previous section.

- When all four cables are routed to the Cable Retaining Block tighten the Cable Nut to lock the cables into the retainer. Tighten the nut at the top of all four Posts until a minimum 1-inch (25 mm) of thread is exposed above the nut.
- After routing all four cables, verify each cable is properly routed and positioned within its Cable Sheaves and engaged in each Slack Safety Sheave

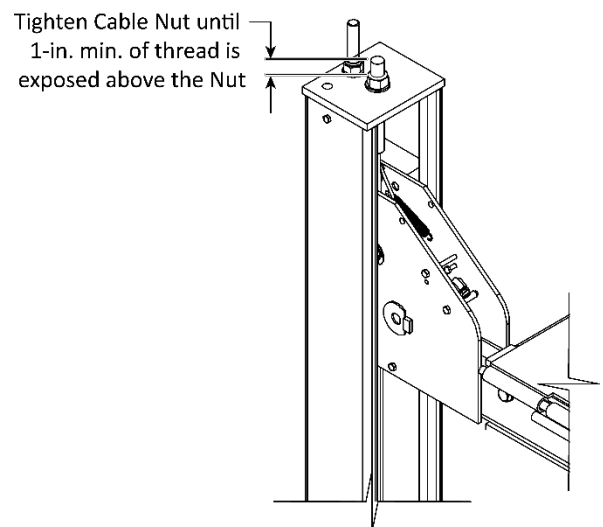

Route the Lifting Cables HD-7500PBX Only

The extended height of the HD-7500PBX requires longer cables and a longer cable path. Review the figure below providing an overview of the routing for all four Lifting Cables on the HD-7500PBX. View this manual in color at www.bendpak.com/car-lifts/four-post-lifts/

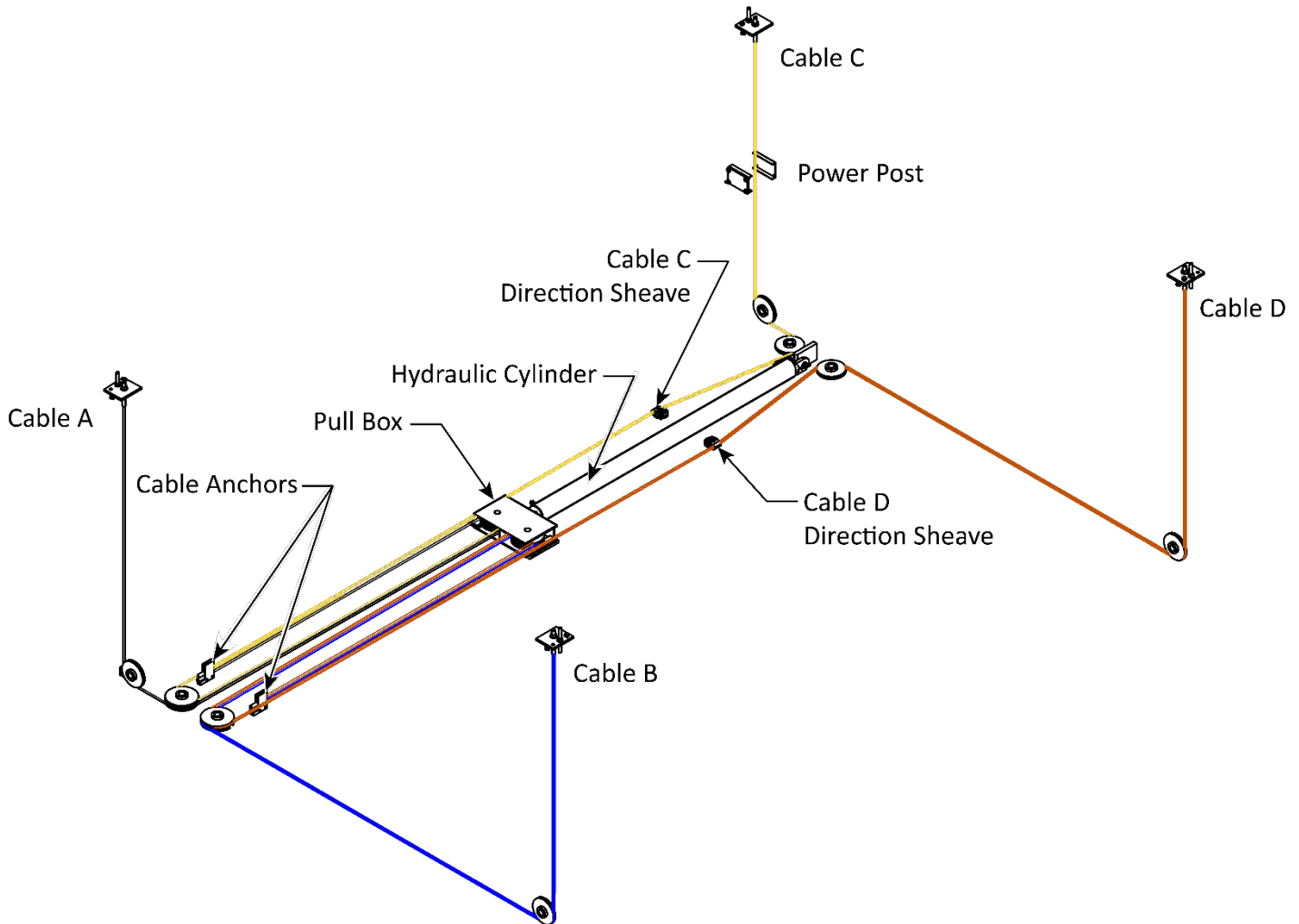

The Cable Anchors, Pull Box, Hydraulic Cylinder and both Cable Direction Sheaves are located under the Power Side Runway.

Before routing the Lifting Cables, extend the Piston on the Hydraulic Cylinder.

To extend the Piston:

1. Remove the Shipping Plug from the Return Line Connector.
2. The Return Line Connector is on the Cylinder end closest to the Power Unit bracket.
3. Attach an air pressure source to the Return Line Connector.
4. Use the air pressure to extend the Hydraulic Cylinder's Piston. **Do not exceed 50 psi.**
5. If the Cylinder does not move, disconnect the air, and use a pulling device (such as a Come Along Tool) to extend the Piston; be careful not to damage the Piston.
6. Reinstall the Shipping Plug into the Return Line Connector to keep the system free of contaminants.

To route the Cable assemblies on the HD-7500PBX:

Review the following Cable List and identify each Cable before beginning.

1. Inspect the Cables to verify the correct lengths are selected for installation.

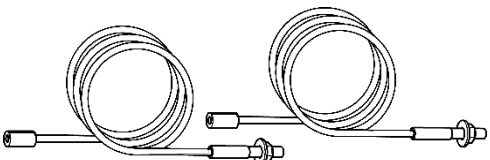
HD-7500PBX Cable Assemblies			
Cable	Description	P/N	
A	Ø10 x 3,228 mm	5595351	
B	Ø10 x 5,471 mm	5595191	
C	Ø10 x 8,570 mm	5595710	
D	Ø10 x 10,830 mm	5595711	

2. Retrieve Cables A and C.
3. **Starting with Lifting Cable A**, move the entire Cable to just under the Large Window in the Crosstube it travels through, near the Post A.
4. Remove the Nut and Washer from the Threaded End (keep it nearby, you will need it soon).

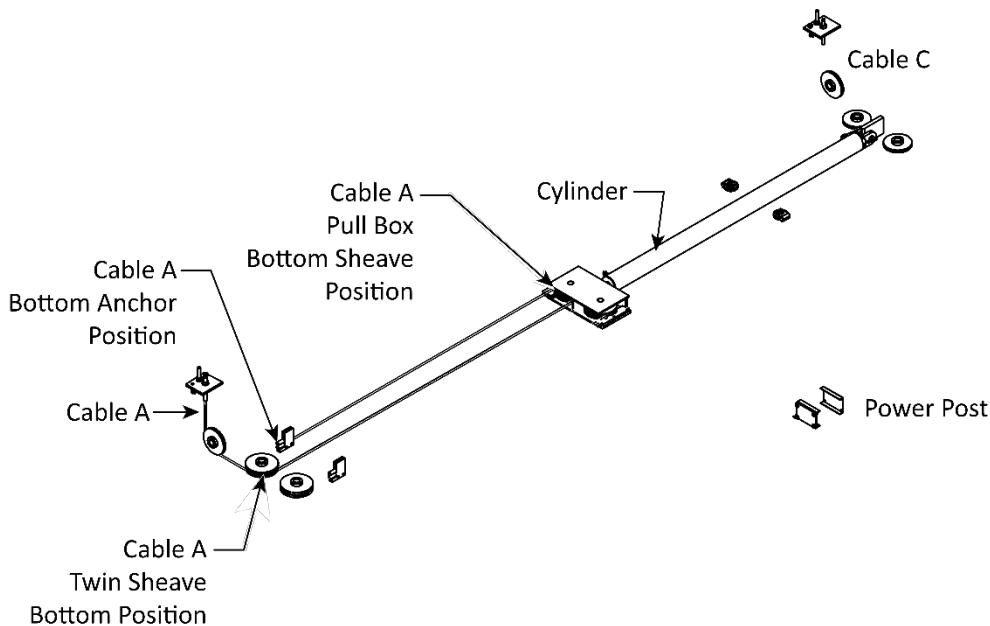

5. Route the Threaded End of Lifting Cable A into its Large Window on the Crosstube, push it towards Post A, and then pull the Threaded End out of the Crosstube at the bottom of the Gusset.

⚠ DANGER When routing the Cables through the Crosstubes verify the cables run below the platform mounting bolts in the Crosstubes. Severe injury or product damage could occur if cables are routed incorrectly.

6. Route the Threaded End of Lifting Cable A **under** where the Gusset Sheave will be installed, then route it up toward the top of the Post past the top of the Crosstube Gusset.

Important: Before re-installing any Sheave, lubricate the Pin and Bearing using a liberal amount of Red Lithium Grease.

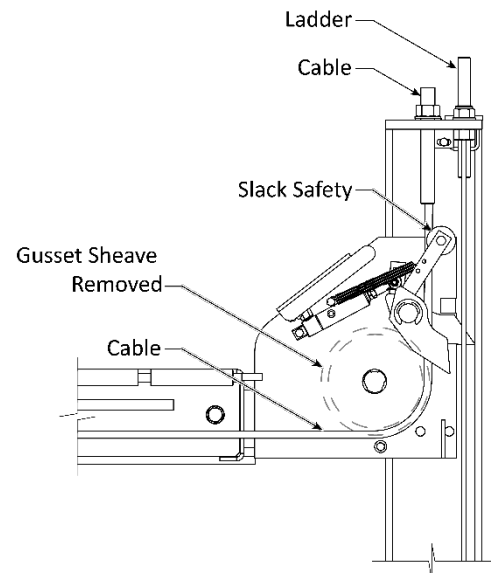

Important: When routing a Lifting Cable in its Post, it must run **under** where the Gusset Sheave will be positioned then, when the Cable heads up toward the top of the Post, it **must** run between the Gusset Sheave and the Slack Safety Sheave.

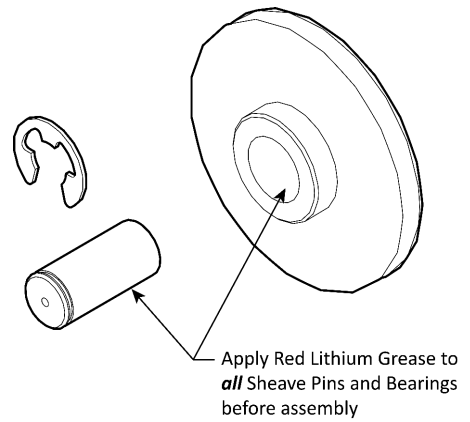

7. Route the Cable over the Slack Safety Sheave.
8. With the Lifting Cable in place, reinstall the Gusset Sheave and the Cable Lock Pin in Post A.
9. Push the Threaded End of Lifting Cable A up to and through the Top Cap (at the top of the Post) and **hand tighten** until at least 2-3 threads are above the Nut and Washer removed earlier. All four Nuts will be tightened later in the installation procedure.
7. **Retrieve Lifting Cable C**, move the entire Cable to just under the Crosstube Small Window it travels through, near the Power Post.
10. Remove the Nut and Washer from the Threaded Cable End (keep it nearby, you will need it soon).
11. Route the Threaded End of Lifting Cable C into its small Window on the Crosstube, push it towards Post C, and then pull the Threaded End out of the Crosstube at the bottom of the Gusset.
12. Route the Threaded End of Lifting Cable C **under** where the Gusset Sheave will be installed, then route it up towards the top of the Post past the top of the Crosstube Gusset.

Important: When routing a Lifting Cable in its Post, it must travel **under** where the Gusset Sheave will be positioned then, when the Cable heads up toward the top of the Post, it **must** run between the Gusset Sheave and the Slack Safety Sheave.

Important: Before re-installing any Sheave, lubricate the Pin and Bearing using a liberal amount of Red Lithium Grease.

13. With the Lifting Cable in place, reinstall the Gusset Sheave and the Cable Lock Pin in Post C.
14. Push the Threaded End of Lifting Cable C up to and through the Top Cap (at the top of the Post).
15. Install the washer and nut removed earlier and **hand tighten** until at least 2-3 threads are above the Nut and Washer removed earlier. All four Nuts will be secured later in the installation procedure.
16. Route Cable C as in the figure to the right. Through the Direction Sheave and over to the Large Window in the Crosstube.

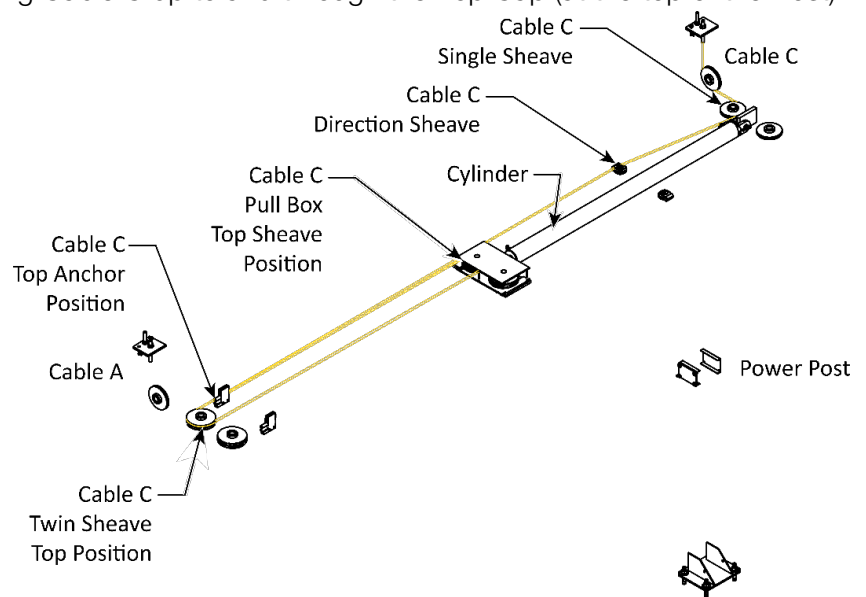

17. Push both Lifting Cables A and C into the Large Window where the Twin Cable Sheave will be installed and pull the Button ends towards the Cable Pull Box.
18. With the Cables in place in the Large Window, reinstall the Twin Cable Sheave; make sure Lifting Cable A is set in the Bottom Cable Sheave, and Cable C is in the top Sheave. Lubricate the Sheave Pin with red lithium grease.

**Power Side Platform
Bottom View**

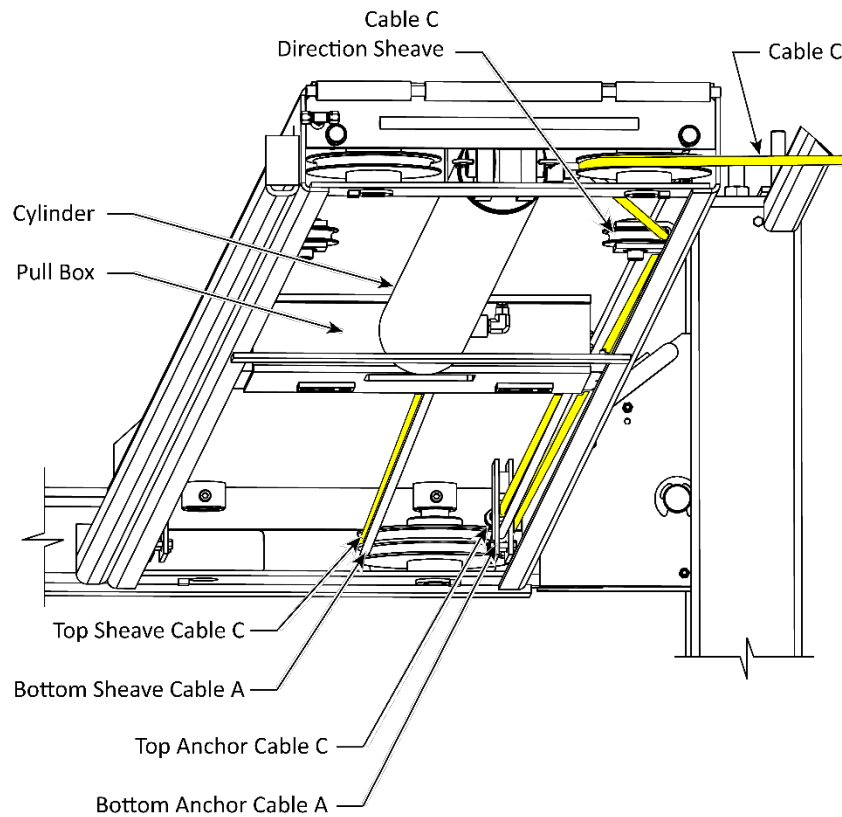

**Platform Removed
Top View**

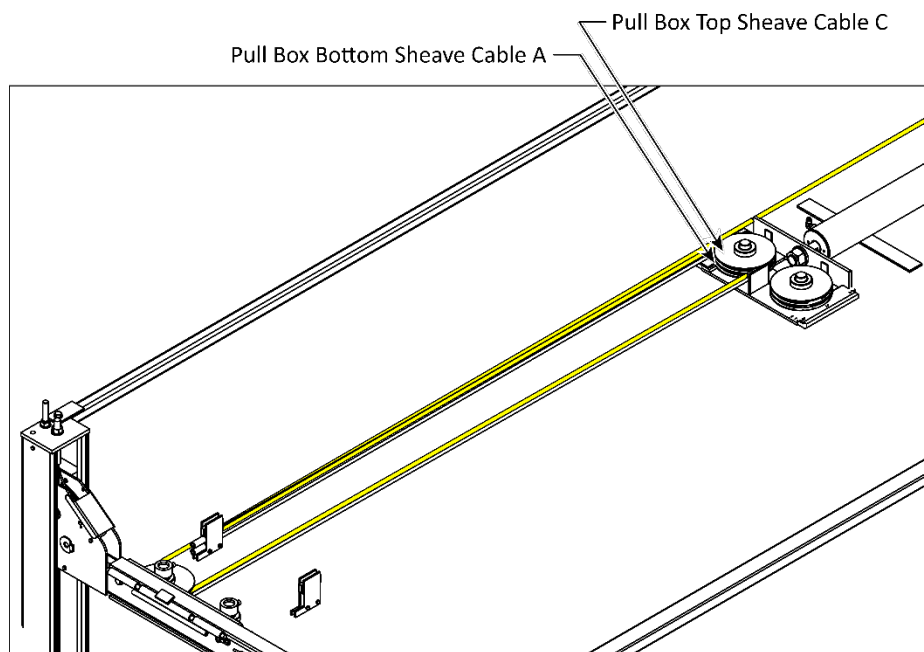

19. Route Cables A and C to the Pull Box. Reinstall the Twin Sheave Assembly with the Cables. Verify Cable C is in the Top Sheave and Cable A is in the bottom.

IMPORTANT! Verify the Cables have not become twisted around each other and that they are riding correctly in the Cable Sheaves.

Pull Box Components

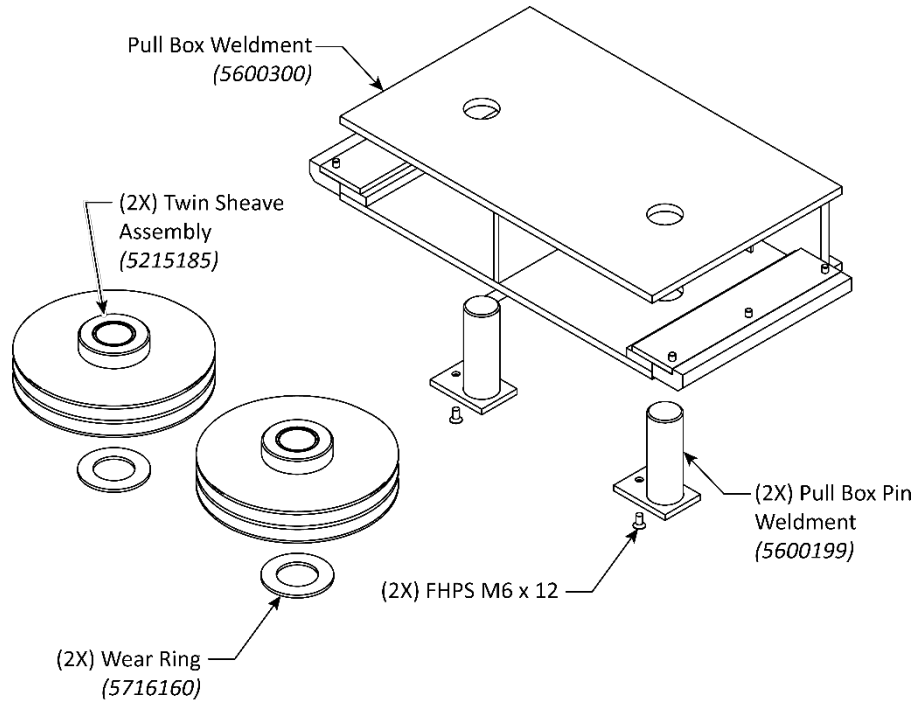

20. Insert the button ends of Cables A and C into the Cable Anchor Plate. Cable C on top and Cable A in the bottom position.

21. Secure the Cables A and C in the Anchor Plate.

22. Routing Lifting Cables B and D is the same process as routing Lifting Cables A and C but uses the remaining two Posts and Sheaves. Refer to the drawings in the previous section and to the figures below.

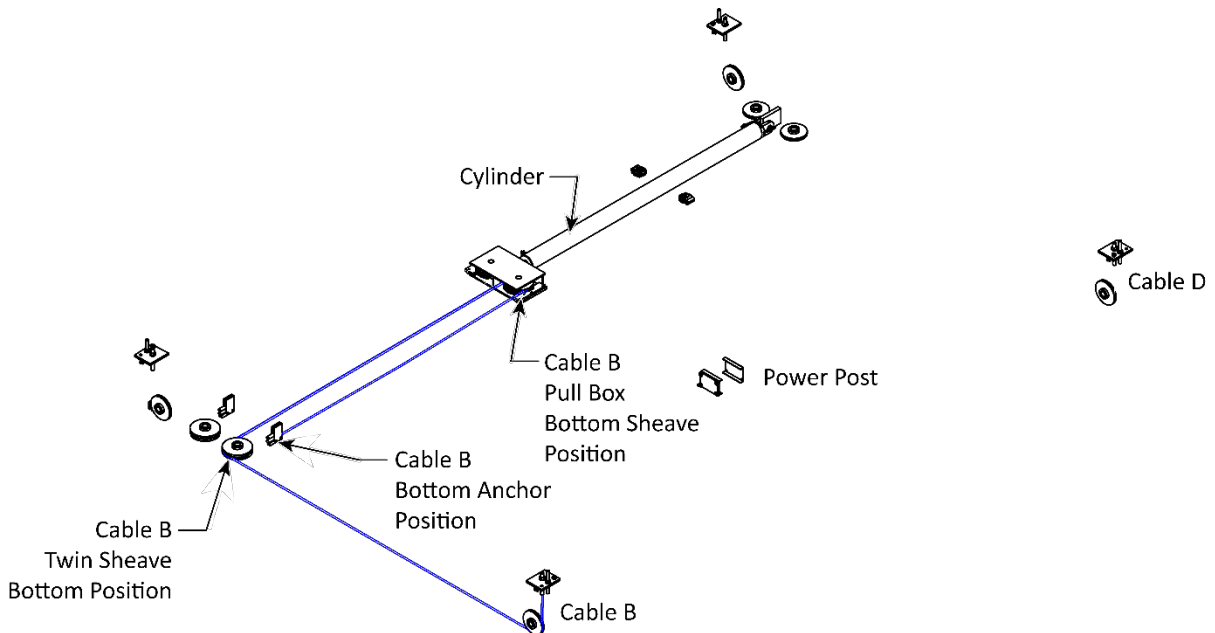

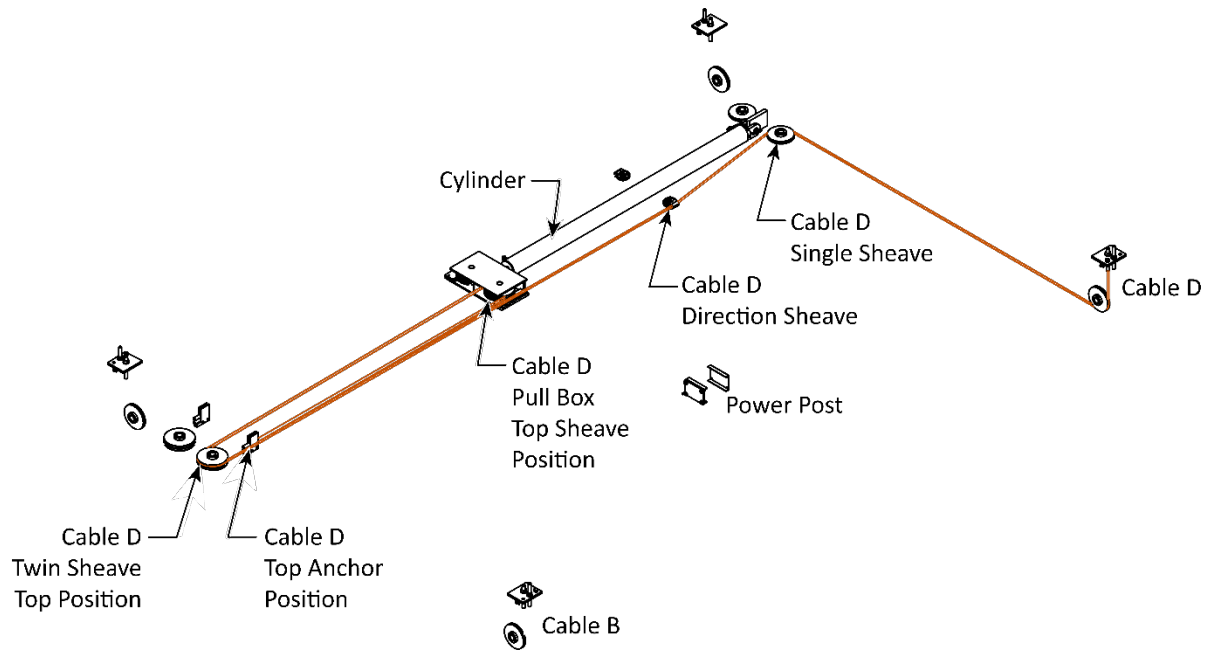

23. Tighten the Threaded Cable End at the top of all four Posts until a minimum of 1-inch (25 mm) of thread is exposed above the nut.
24. After routing all four cables, verify each cable is properly routed and positioned within its Cable Sheaves and engaged in each Slack Safety Sheave.

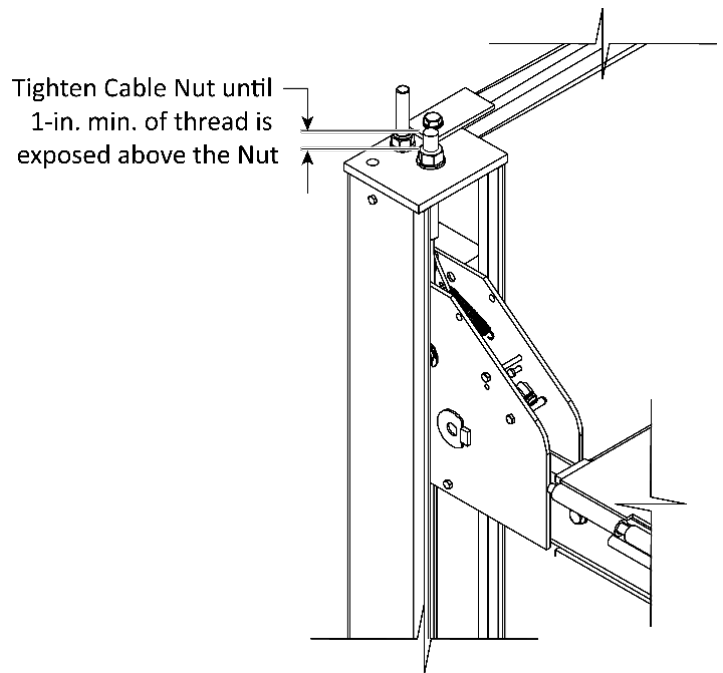

Install the Power Unit

This section describes how to **install**, but not make the connections to, the Power Unit for the Lift. An Electrician is **not** needed to *install* the Power Unit; however, an Electrician **is** required to *connect* the Power Unit to its power source.

The Power Unit **must** be installed on the Power Post: attach it to one of the two Mounting Brackets, whichever is more convenient for the location.

Important: May customers install the Flex Tube Bracket Plate and the Zero Angle Bracket at the same time as they install the Power Unit. Read **Installing the Second End of the Flex Tube** and **Installing the Pushbutton Air Valve** for more information to see if this makes sense for your installation.

⚠ DANGER Risk of explosion: The Power Unit has internal arcing or parts that may spark and should not be exposed to flammable vapors. Never expose the Power Unit motor to rain or other damp environments. Damage to the motor caused by water is **not** covered by the warranty.



Tip

The Power Unit is heavy. BendPak recommends having one person hold the Power Unit while another person bolts it into place.

To install the Power Unit:

1. Locate the four supplied Hex Head Bolts, Flat Washers, Nyloc Nuts, and the Vibration Dampener.
2. Line up the holes on the Vibration Dampener with the four holes on the Mounting Bracket.
3. If installing the Flex Tube Bracket Plate and/or the Zero Angle Bracket at the same time as the Power Unit, put them into place.
4. Install a Flat Washer onto each of the four Hex Head Bolts, slide the Bolts with washers through the back of the Mounting Bracket and through the holes in the Vibration Dampener. Then thread on the Nyloc Nuts to secure the Power Unit in place.

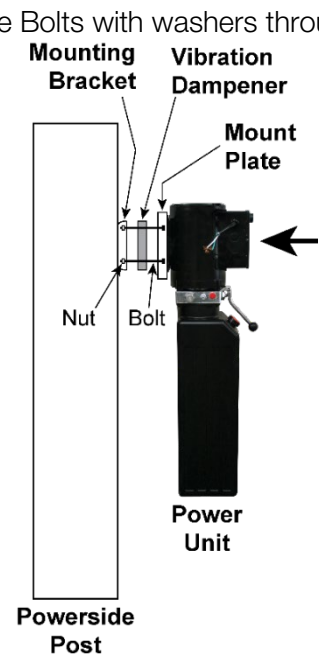



IMPORTANT! PLEASE READ NOW



Hydraulic Fluid Contamination

Hydraulic Fluid Contamination presents a serious issue for hydraulic components; contaminants such as water, dirt, or debris can enter the Hydraulic Hoses and Fittings on the Lift, potentially making your new Lift inoperable.

Your Lift is shipped with clean components; however, BendPak strongly recommends that you clean all Hydraulic Hoses and Fittings prior to making connections. It is better and less costly to take these extra steps now so that you do not need to take your Lift out of service later to fix issues that could have been prevented at the time of installation.

There are several methods available to clean Hydraulic Hoses and Fittings:











- **Compressed Air.** Blow out contaminants from each Hydraulic Hose and Fitting prior to installation. Use clean, dry air. Wear eye protection (safety glasses, goggles, or a face shield) when using compressed air for cleaning. Never point an air hose nozzle at any part of your body or any other person.
- **Fluid Flushing.** As long as the Hydraulic Fluid is clean and compatible with the system fluid, the Hoses and Fittings may be flushed to create turbulent flow and remove particulates. Always ensure that the fluid itself is contaminant-free.

Some additional steps that will help keep the Hydraulic Fluid clean:

- **Remove old thread seal tape.** Some ports on the Hydraulic Cylinders are shipped with temporary plugs secured with thread seal tape, so make sure to thoroughly remove any leftover thread seal tape that may inadvertently enter the Hydraulic System.
- **Use a liquid thread sealant only.** Teflon paste-type thread sealant or Loctite™ 5452 thread sealant is recommended for all NPT Fittings. Do not over tighten NPT Fittings or they may crack. Never use thread seal tape on JIC Fittings or ORB O-Ring Fittings.
- **Always use clean equipment.** If you use a dirty bucket or funnel to transfer the Hydraulic Fluid into the Hydraulic Fluid Reservoir, the contaminants will likely be introduced into the Fluid. When using cleaning rags, use a lint-free rag.
- **Proper storage.** Keep the Hydraulic Fluid sealed in its container until ready for use; store the fluid in a clean, dry, and cool area.
- **Cover the Hoses and Fittings.** Before installation, do not leave the ends of the fittings exposed; the same applies for the Hydraulic Hoses. As a general rule, keep the Hydraulic Hoses and fittings capped and kept clean in a clean area until ready for use.
- **Filter the new Hydraulic Fluid.** New does not necessarily mean *clean*. Use an offline filtration cart or kidney loop system to make sure the Hydraulic Fluid is clean before being transferred into the Hydraulic Fluid Reservoir (even using a heavy-duty nylon mesh screen is better than trusting what is left at the bottom of the barrel).
- **Avoid mixing different types of Hydraulic Fluid.** If Hydraulic Fluid needs to be replaced, make sure to flush the Hydraulic System of the old Hydraulic Fluid before you add the replacement Fluid; do not mix the two together.

Hydraulic System Warnings

Before applying power to the Hydraulic System, note the following Dangers and Warnings:

-  **DANGER** Failure to observe these warnings can result in severe personal injury including, in rare cases, death.
-  **DANGER** The Hydraulic System may contain high pressure which, if suddenly released, can cause severe injury or death.
-  **DANGER** Changes to the output pressure may render the Power Unit incompatible with pressure limitations on other components in the hydraulic circuit. This may cause catastrophic failure of those components, and could result in property damage, severe personal injury, or death.
-  **WARNING** The Power Unit is a Hydraulic Pump capable of developing pressures in excess of 5,000 psi (345 BAR). A pressure relief valve is used to set the pressure at the desired level. Tampering with, adjusting, modifying, or removing the relief valve is extremely dangerous and is not permitted. Only trained Hydraulics technicians are permitted to adjust the relief valve, using calibrated hydraulic pressure gauges to ensure the proper pressure setting is achieved.
-  **WARNING** The Hydraulic hoses and connections **must** be inspected before any attempt to raise a Vehicle is made.
-  **WARNING** **Verify all** Hydraulic Hose connections and fittings, including unused auxiliary port plugs on the Power Unit, the Cylinders and anywhere else in the Hydraulic System are tightened.
-  **WARNING** Do **not** attempt to connect or disconnect Hydraulic Hoses while the equipment is loaded or while a Vehicle is on the Lift, or the Hydraulic System is under pressure.
-  **WARNING** Keep bare hands away from Hydraulic Fluid; always wear gloves when handling Hydraulic Fluid, Cylinders or Hydraulic Hoses.
-  **WARNING** When handling Hydraulic Fluid, always observe the safety instructions from the manufacturer.
-  **WARNING** **Always** promptly clean any Hydraulic Fluid spills. If a leak in the system is the source of the spill, lockout the Lift to prevent use until the Hydraulic System is repaired.

About Thread Sealants

Liquid Thread Sealant lubricates and fills the gaps between the Fitting threads and leaves no residue that could contaminate the Hydraulic Fluid.

Other types of Thread Sealants (like Teflon Tape) can shred during installation or removal and eventually enter the Hydraulic System.

Thread Sealant can be used with most Hydraulic Fittings, although you probably only need to use with NPT connectors.

Apply the thread sealant when the ambient temperature is between +46.5°F to +70°F (+8°C to 21°C)



To apply Thread Sealant:

5. Make sure the Fittings and connectors are clean and dry.

If you are adding Thread Sealant to a Fitting or connector that has already been used with a different sealant, use a wire brush to thoroughly remove the old sealant before adding more.

6. Skipping the first thread, apply a small amount of Thread Sealant to the next four threads of the Fitting.

⚠ WARNING Always wear the proper protective equipment when handling Thread Sealant.

Only a small amount is required. The sealant will spread to the other threads as it is tightened into place. Any excess liquid will be pushed out as the Fitting is tightened; use a rag to wipe away any excess.

7. Tighten the Fitting into the connector; do **not** over tighten the Fitting.
8. Allow the **24-hour** manufacturer-recommended curing time before pressurizing the system.

Fill the Hydraulic Fluid Reservoir

The Hydraulic Fluid reservoir on the Power Unit must be filled with Hydraulic Fluid or automatic transmission fluid before you begin normal operation of the Lift. **When you receive the Lift, the fluid reservoir is empty.**

The Power Unit will **not** work correctly until it is filled with approved Hydraulic Fluid.

Approved fluids are any general purpose ISO-32, ISO-46, or ISO-68 hydraulic fluid, approved automatic transmission fluids such as Dexron III, Dexron VI, Mercon V, Mercon LV, or any synthetic multi-Vehicle automatic transmission fluid.

⚠ WARNING Do not run your Power Unit without Hydraulic Fluid; you will damage it.

To fill the Reservoir with Hydraulic Fluid:

1. Remove the Reservoir Cap and set it aside.

Make sure to keep the Reservoir Cap clean; do not allow contaminants to enter the Hydraulic Fluid Reservoir.

2. Fill the Hydraulic Fluid Reservoir on the Power Unit with the appropriate amount of approved fluid. Several power units are available. The fluid capacity of several common units are detailed below. Always refer to your actual unit for the exact capacity. Power units commonly shipped with these lifts are shown here.

The Hydraulic Reservoir holds from 3.5 to 3.7 gallons, depending on your Power Unit:

- **5585280**: 3.7 gallons / 14 liters
- **5585079**: 3.5 gallons / 13.25 liters
- **5585780**: 3.6 gallons / 13.6 liters
- **5585014**: 3.7 gallons / 14 liters

Use care to keep the fluid clean when filling the reservoir.

Do not connect the Power Unit to a power source at this point.

3. Replace the Reservoir Cap.

Install the Second End of the Flex Tube

Once the Power Unit is installed, you can install the second end of the Flex Tube (the other end was connected to the Power Side Runway earlier in the installation).

To install the Flex Tube:

1. Find the Flex Tube Bracket Plate and the Flex Tube Angle Plate. The Flex Tube is already nearby.
2. Install the Flex Tube Bracket Plate.

Note: It is common to install the Flex Tube Bracket Plate between the Mounting Bracket and the Back Plate. This allows the Zero Angle Bracket (which holds the Pushbutton Air Valve and is described in the next section) to be installed between the Back Plate and the retaining Nut. This configuration is common, but it is not required.

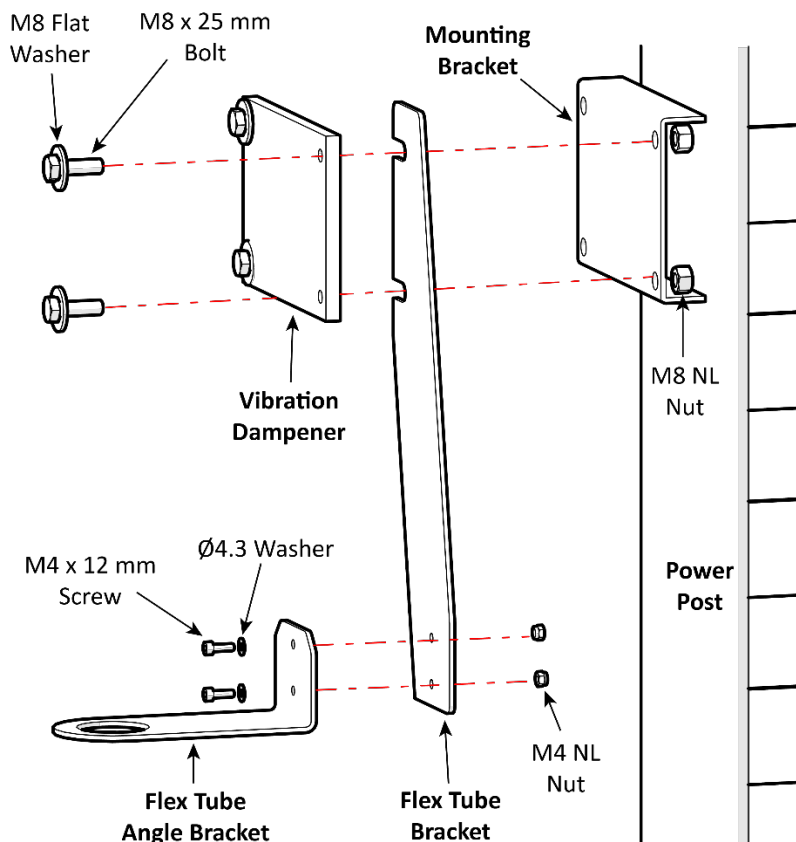

Side view of where the Power Unit attaches to the Power Post. Power Unit not shown.

3. Connect the Flex Tube Angle Plate to the Flex Tube Bracket Plate so that the hole for the Flex Tube is best positioned for connecting the Return Line, the Air Line, and the Hydraulic Hose.

The Flex Tube Angle Plate can be connected on either side of the Flex Tube Bracket Plate.

4. When the Flex Tube Angle Plate is in place, unscrew the Plastic Nut from the end of the Flex Tube.
5. Holding the Flex Tube by the Plastic Collar, put the Threads through the hole on the Flex Tube Angle Plate **from underneath**.
6. Screw the Plastic Nut back onto the threads and tighten.

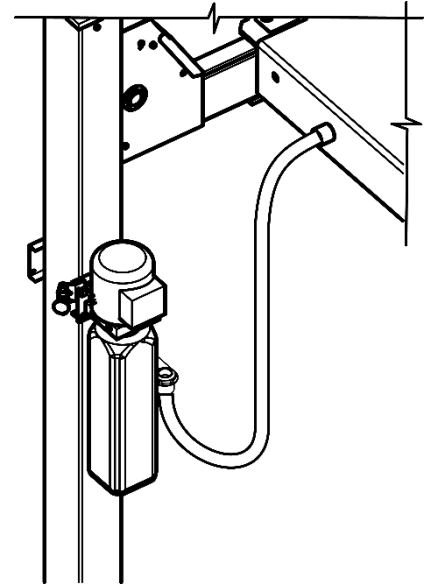

Working with Compression Fittings and Tubing

The Lift is supplied with a roll of ¼ inch, black, polyethylene Tubing (also called Poly-Flo® Tubing). This tubing is used with Compression Fittings to supply air pressure to release the Safety Locks and to provide a Return Line for hydraulic fluid to the reservoir.

Important: While both lines use Tubing and Compression Fittings, the Return Line and Air Lines are used for completely separate purposes; do not connect the two together.

Note: Compression Fittings are different from Hydraulic Fittings. This section covers Compression Fittings only.

The components involved with Compression Fittings include:

- **¼ inch, black, polyethylene Tubing.** Use a single section of Tubing for the Return Line. The Air Lines require multiple Tubing sections. Create the Tubing sections for both the Return Line and the Air Lines by cutting lengths from the long roll of Tubing supplied with your Lift.
- **Elbow Compression Fittings.** The Return Line uses two Elbow Compression Fittings.
- **Tee Compression Fittings.** The Air Lines require three Tee Compression Fittings.
- **Nuts, Ferrules, Rods, and Threads.** Each connector on Elbow and Tee Compression Fittings has a Nut, Ferrule, Rod, and Threads (see drawing below). The Nut holds the Tubing and Fitting together. The Ferrule compresses when you tighten the Nut on the Threads to make a secure connection. The Rod runs inside the Tubing to seal.

The following drawing shows the components of a connector on a Tee Compression Fitting.

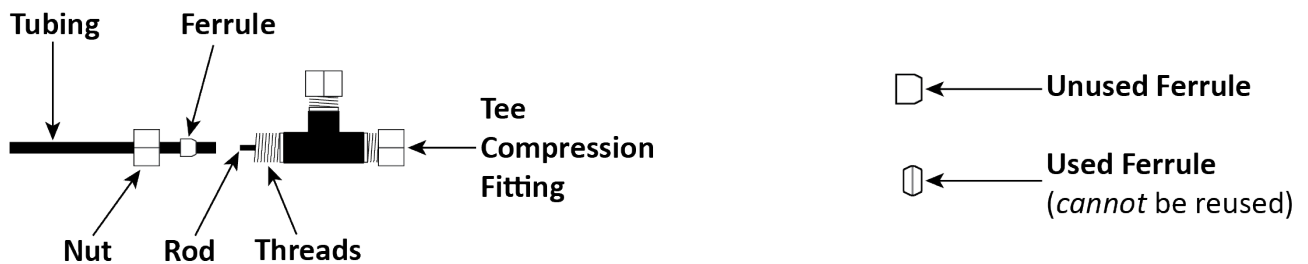

Important: **Ferrules should only be tightened once.** When you tighten the Nut on the Threads, the Ferrule is compressed; the Ferrule should not be reused after this compression.

To connect Tubing to a Compression Fitting:

1. Push the Tubing through the Nut and over the Rod.
Do not push hard; you only need the Tubing to go a little way over the Rod. You cannot see the Ferrule at this point, but the Tubing must go through the Ferrule and over the Rod.
2. Slide the Nut on the Tubing **away from the Fitting**; if the Nut is still on the Threads, unscrew it from the Threads and then slide it away from the Fitting. See the drawing above.
3. Slide the Ferrule over the Tubing, away from the Fitting and towards the Nut.
4. With the Nut and the Ferrule out of the way, push the Tubing farther over the Rod until it stops.
5. Slide the Ferrule and the Nut back to the Threads on the Fitting.
The Ferrule installs around the Rod and under the Threads. The Nut runs onto the Threads.
6. Tighten the Nut.
Remember that the Ferrule should only be used once; tighten the Nut last.

Install the Pushbutton Air Valve

The Pushbutton Air Valve is used to lower the Runways. It may be installed on either side of the Power Unit; whichever side is easier to access for the Lift operator.

Once the pushbutton is in place, connect it to both the Lift Air Line (exiting out of the Flex Tube) and the customer-supplied air pressure. **An Air Supply (3 to 25 cfm at 50 to 150 psi max.) is required.**

The following drawing shows the Zero Angle Bracket and where it connects.

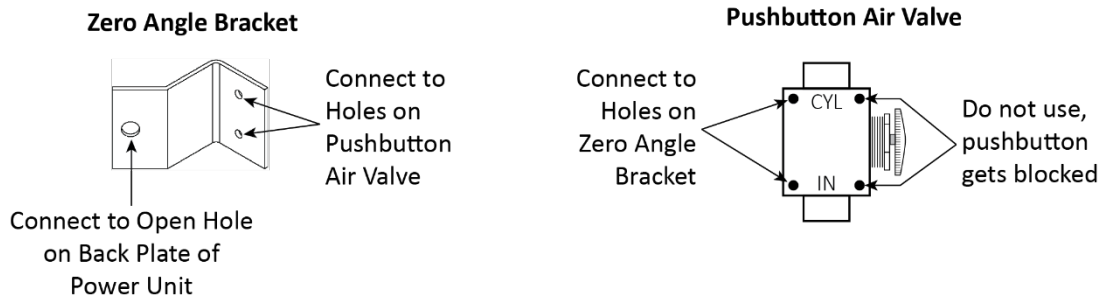

The following figure details the Pushbutton Air Valve and its connections.

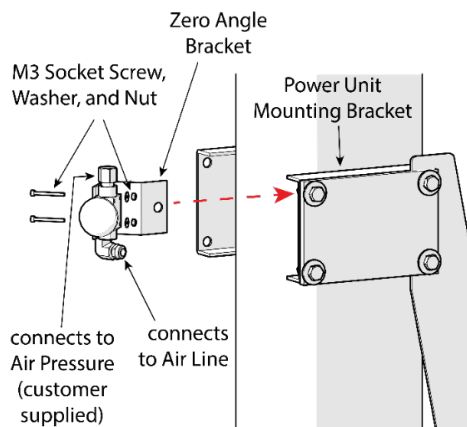

The components involved include:

- **Zero Angle Bracket.** Attaches at the Mounting Bracket on the Power Post or to other available holes on the Back Plate of the Power Unit. Holds the Pushbutton Air Valve, so be sure to orient the Zero Angle Bracket so that the Pushbutton Air Valve can be easily reached by the Lift operator.
- **Pushbutton Air Valve.** Used to lower the Runways.
- **Air Line Compression Elbow Fitting.** Connects the Pushbutton Air Valve to the Air Line coming out of the Flex Tube.
- **Straight Expander Fitting.** Connects the Pushbutton Air Valve to the customer-supplied air pressure.

To install the Pushbutton Air Valve:

1. Retrieve the necessary components: Zero Angle Bracket, Pushbutton Air Valve, Air Line Compression Elbow Fitting, and Straight Expander Fitting.
2. Connect the Zero Angle Bracket at the desired location (if it has not already been connected).
It can attach to an available hole on the Back Plate of the Power Unit or to one of the Bolts that connect the Power Unit to the Mounting Bracket on the Power Post.
3. Connect the Pushbutton Air Valve to the Zero Angle Bracket.
Use the two holes on the Pushbutton Air Valve on the side away from the actual pushbutton. If you use the holes next to the pushbutton, the Zero Angle Bracket interferes with the pushbutton when you try to use it.
4. Connect the Air Line Compression Elbow Fitting and the Straight Expander Fitting to the appropriate locations on the Pushbutton Air Valve.
The elbow fitting connects to the opening labelled **CYL**. The straight fitting to the opening labelled **IN**. See the drawing above.
5. Attach the Air Line (coming out of the Flex Tube) to the compression fitting on the elbow fitting and the customer-supplied air to the straight fitting.

Important: The Return Line also comes out of the Flex Tube and is the same kind of tubing as the Air Line. **Do not attach the Return Line to the Pushbutton Air Valve by mistake.** Double check to make sure you are attaching the Air Line to the Pushbutton Air Valve.

Install the Air Lines

This section describes the Air Line installation. Air pressure is used to disengage the Safety Locks allowing the Runways to lower.

Retrieve the ¼ inch, black, polyethylene Tubing and three Compression Tee Connectors.

An Air Supply (3 to 25 cfm at 50 to 150 psi) is required to disengage the Safety Locks. Regulate the line to a maximum pressure of 150 psi.

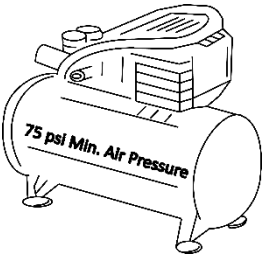
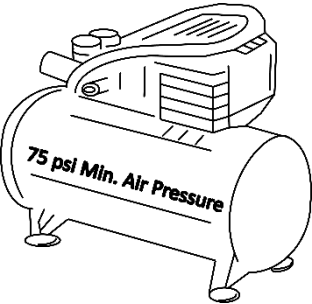
3 Levels of Suggested Air Compressors for HD-9 Operation				
Model Level	Service Size	Air Tank Volume	CFM	Minimum Operational PSI
Good		3 Gallon Min.	3 to 25	50
Better		10 Gallon Min.	3 to 25	50
Best		20 Gallon Min.	3 to 25	50

⚠ CAUTION Do not allow the Air Supply to exceed 150 psi; the Air Lines could burst or the Safety Locks malfunction.

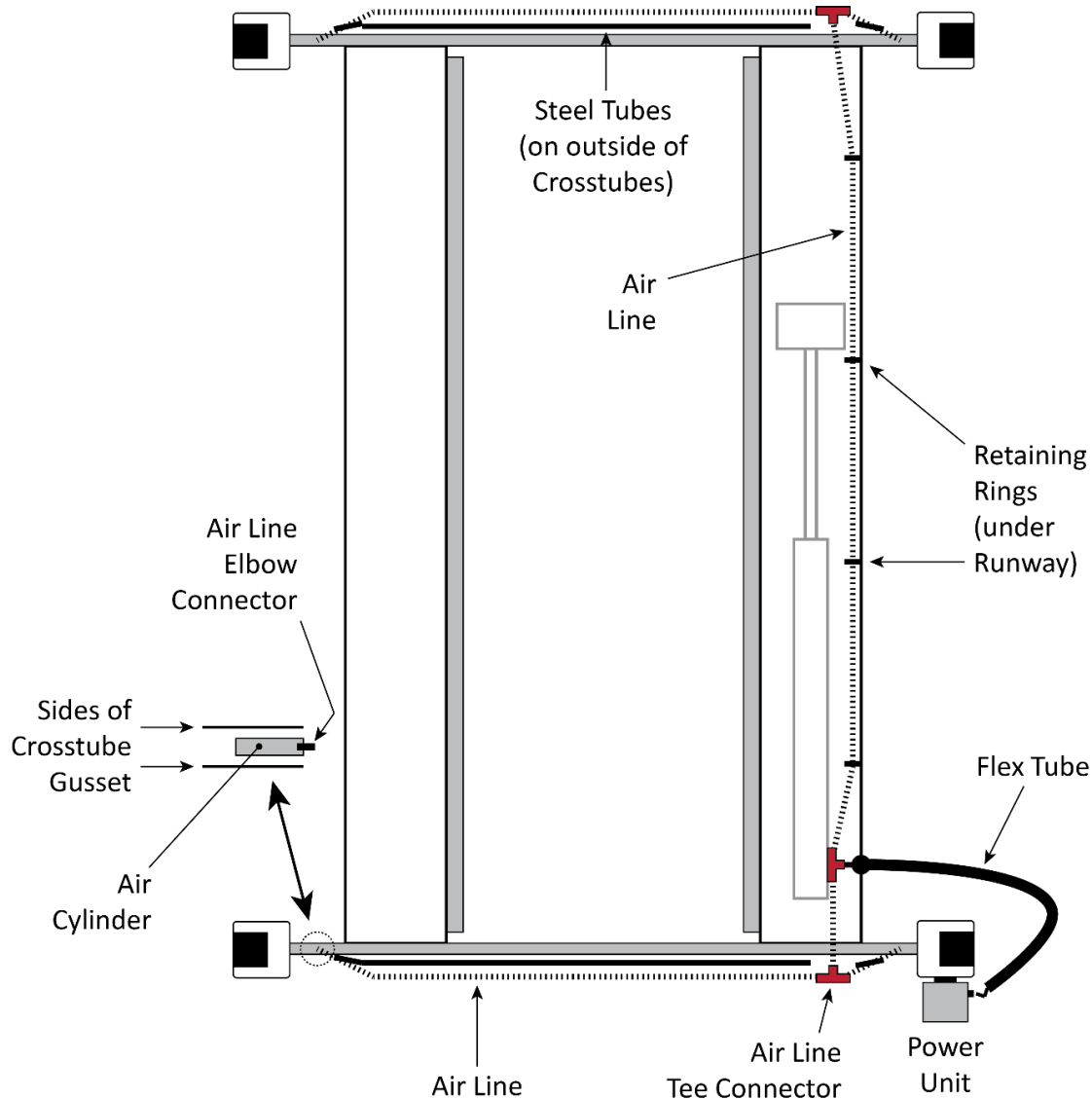

Drawing not to scale. Some components not shown. Air Lines shown outside Steel Tubes for clarity.
 The Air Line Elbow Connectors on the Air Cylinders are delivered installed from the factory.

Important: Do not confuse the Air Lines with the Return Line. They use the same Tubing and fittings, but they are used for completely different things; the two systems **must not** be connected to each other.

To install the Air Lines:

1. Retrieve the roll of supplied ¼-inch, black, polyethylene Tubing and three Air Line Tee Connectors.
2. Measure the distances for each of the seven (7) Tubing sections you will need (see the drawing on the previous page).
3. Cut seven sections of Tubing to the measured lengths from the roll of Tubing.
4. Connect the various sections of Tubing to the Air Line Tee Connectors on the Lift.

Refer to the drawing above for the locations of the Tubing sections.

Make sure to position the three Air Line Tee Connectors as shown in the drawing.

Make sure to route the long Tubing section that runs under the Power Side Runway through the Retaining Rings. Verify the Air Lines do not interfere with the Lifting Cables.

 **CAUTION** Make sure to route the Tubing sections on the **outside** of the Front and Rear Crosstubes *through the Steel Tubes* welded on the Crosstubes. This keeps the Tubing and the Tee Connectors from being disturbed as you use the Lift. This is important, because if the Air Lines are damaged, the Safety Locks on the Lift may not work correctly. If you notice that Tubing has become disconnected from an Air Line Tee Connector, take the Lift out of service, and repair the Air Lines.

Refer to **Working with Compression Fittings and Tubing** for more information about connecting the Tubing to the Air Line Tee Connectors.

5. Leave the Power Unit end of the Air Line hanging out of the Flex Tube for now. It will be connected to the Pushbutton Air Valve later in the installation process.

Install the Return Line

The Return Line routes excess Hydraulic Fluid from the Hydraulic Cylinder back into the Fluid Reservoir on the Power Unit.

The Return Line is a single section of ¼-inch, black, polyethylene Tubing with Elbow Compression Fittings on each end.

Important: The Return Line uses the same ¼-inch, black, polyethylene Tubing as the Air Lines. Be sure not to confuse the two: the Return Line and the Air Lines do completely different things and **must** be kept separate from each other.

The figure below details the Return Line path and connections.

To install the Return Line:

1. Measure the distance from the Return Line Port on the Hydraulic Cylinder to the Hydraulic Return Port on the Power Unit.
2. Cut a section of Tubing to the measured length from the roll of Tubing delivered with the Lift.
3. Route the Tubing from the Hydraulic Cylinder, through the Retaining Rings on the underside of the Power Side Runway, through the Flex Tube, and out next to the Power Unit mounting.
4. Remove the Shipping Plug from the Return Line Port on the Hydraulic Cylinder.
5. Connect and tighten the NPT end of the Elbow fitting to the Return Line Port and the compression end connects to one end of the Return Line.

Use Liquid Thread Sealant on NPT threads only.

Refer to [Working with Compression Fittings and Tubing](#) for instructions.

6. Take the second Compression Elbow Fitting and connect the NPT end to the Power Unit, and the compression end to the other end of the Return Line (coming out of the Flex Tube).

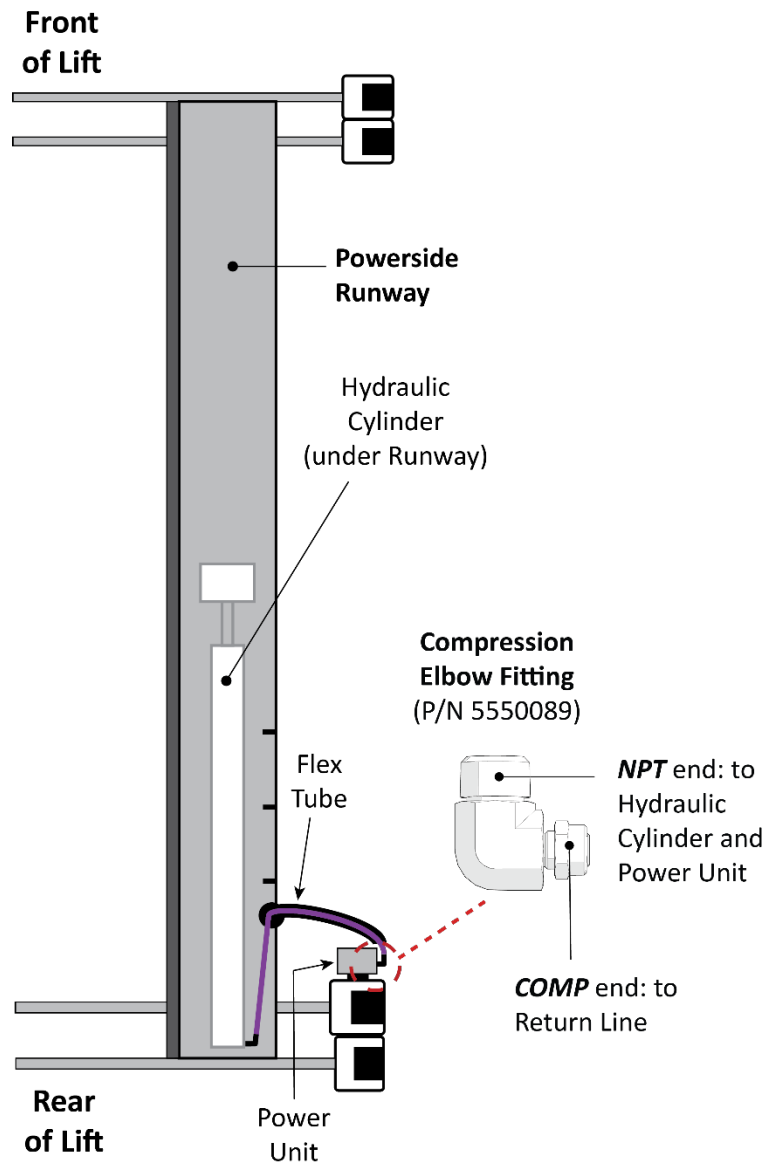

Top View of Power Side Runway. Drawing not to scale. Some components not shown or exaggerated for clarity.

Install the Hydraulic Hose

The Hydraulic Hose moves Hydraulic Fluid from the Power Unit to the Hydraulic Cylinder. The figure below displays the Hose path and connections. The Hose end with the 90° fitting is to be connected at the Hydraulic Cylinder, the straight fitting is connected to the Power Unit.

To install the Hydraulic Hose:

1. Retrieve the Hydraulic Hose and two Hydraulic Fittings.
 2. Push the Hydraulic Hose through the Flex Tube with the Curved end connecting to the Hydraulic Cylinder and the Straight end connecting to the Power Unit.
- Route the Hydraulic Hose through the Retaining Clips along the side of the Runway.
3. On the Hydraulic Cylinder, remove the Shipping Plug from the Port at the Piston / Retainer Block end.

Route the Hydraulic Hose through the Retaining Clips along the side of the Runway.

4. Attach the NPT connector of the JIC x NPT Fitting to the Hydraulic Cylinder Port (where you just removed the Shipping Plug) and tighten it.

Use Liquid Thread Sealant on the NPT threads only.



Tip Leave the JIC end pointing up; this will direct the Hydraulic Hose up and away from where the Lifting Cables will be installed.

5. Attach the Curved end of the Hydraulic Hose to the JIC connector that is facing up and tighten it.
 6. Locate the Hydraulic Pressure Port on the Power Unit and remove the Shipping Plug.
- See [Connecting to a Power Source](#) for Port locations.
7. Connect the ORB end of the ORB x JIC Fitting to the Power Unit Port and the JIC end to the Straight end of the Hydraulic Hose.

8. Securely tighten all connections.

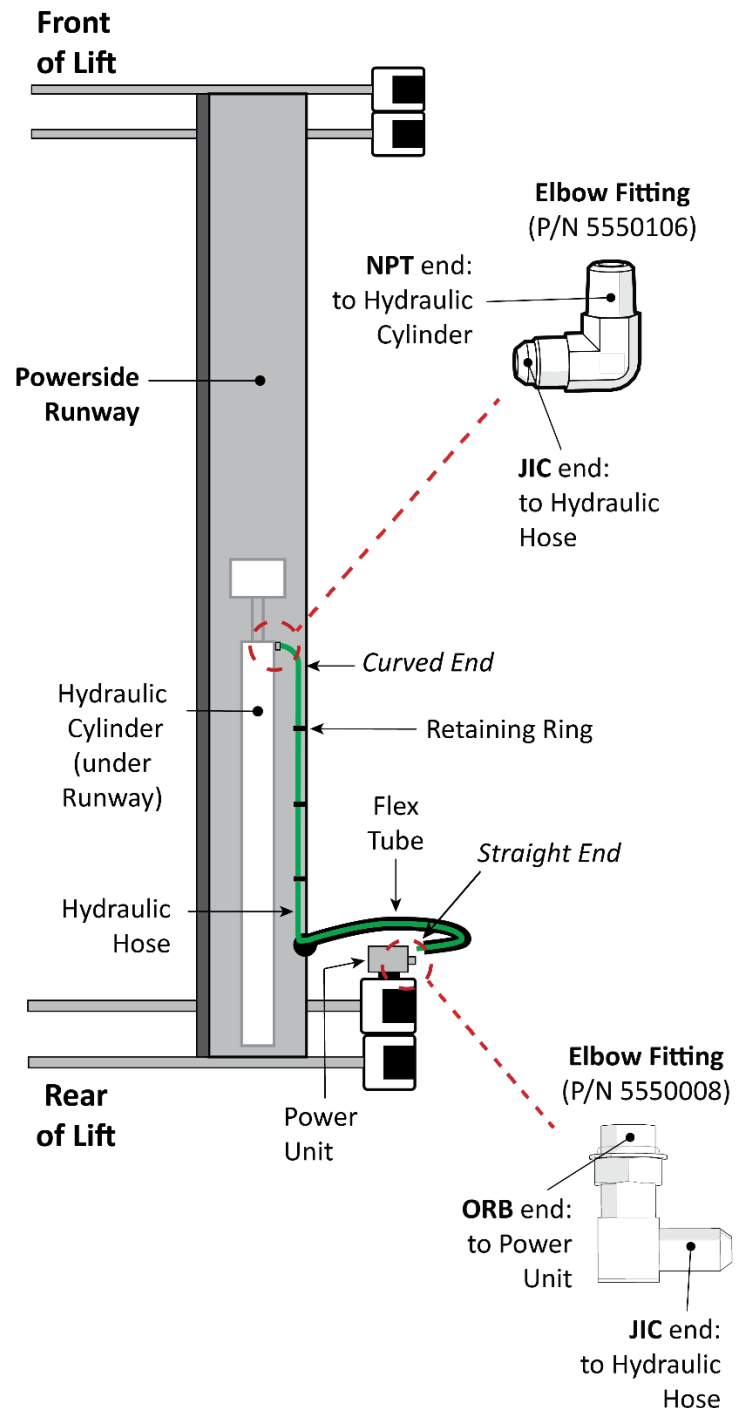

Top view of the Power Side Runway. Drawing not to scale. Some components not shown or exaggerated for clarity.

Contact the Electrician

As mentioned previously, there are installation tasks that **require** a licensed Electrician.

⚠ DANGER All wiring must be performed by a licensed Electrician. In accordance with National, State, and Local electrical codes.

The Electrician is required to:

- **Connect the Power Unit to an appropriate power source.** Refer to **Connecting to a Power Source** for more information.
- **Install a Power Disconnect Switch.** Ensures you can completely interrupt electrical power to the Lift in the event of an electrical circuit fault, emergency, or when equipment is undergoing service or maintenance. You must put it within sight and easy reach of the Lift operator. Refer to **Install a Power Disconnect Switch** for more information.
- **Install a Thermal Disconnect Switch.** Ensures the equipment shuts down in the event of an overload or an overheated motor. Refer to **Install a Thermal Disconnect Switch** for more information. Note that the Power Unit that comes with the Lift is **not** thermally protected.

The electrician is responsible for providing:

- An appropriate cable and plug to attach to the Power Unit, for connection to a wall outlet **or** protected wiring that attaches the Power Unit to the facility's electrical system protected by an appropriate circuit breaker.
- A Power Disconnect Switch
- A Thermal Disconnect Switch

Electrical Information

- Improper electrical installation can damage the Power Unit motor, which is not covered by the warranty.
- The Lift uses electrical energy; if your organization has Lockout/Tagout policies, make sure to implement them after connecting to a power source.
- Use a separate circuit breaker for each Power Unit.
- Protect each circuit with a time delay fuse or circuit breaker:

Connect to a Power Source

⚠ DANGER A licensed Electrician must perform all wiring. Do not perform any maintenance or installation on the Lift without first verifying that main electrical power has been disconnected from the Lift and cannot be re-energized until all procedures are complete. The Lift uses electrical energy; if your organization has Lockout/Tagout policies, make sure to implement them after connecting to a power source.

Important: Make clear to your Electrician that all electrical work **must** conform to applicable local, state, and federal codes, rules, and regulations, such as state and federal OSHA regulations and electrical codes.

To connect the Lift to a power source:

1. Locate the Pigtail exiting the Electrical Box on the Power Unit.

2. Open the Electrical Box, **remove the Pigtail**, and then either wire the Power Unit directly into the facility's electrical system; or wire a power cord with an appropriate plug *inside the Electrical box* (where the Pigtail was wired).

Wiring information is either on the outside of the Power Unit under the Electrical Box or inside the cover of the Electrical Box. Have the Electrician use that wiring information to wire the Power Unit to the power source.

You may also find the Wiring Diagram for your Power Unit in this manual under **Wiring Diagrams**.

3. Close the Electrical Box.

Install a Power Disconnect Switch

⚠ WARNING A main Power Disconnect Switch is **not** provided with this equipment.

A Power Disconnect Switch is a National Electrical Code (NEC) requirement. They are designed to interrupt electrical power in the event of an electrical circuit fault, emergency, or when equipment is undergoing service or maintenance.

The Electrician must install a Power Disconnect Switch that is properly rated for the incoming power.

⚠ DANGER A licensed Electrician must perform all wiring.

Your Power Disconnect Switch must be readily accessible and installed so that it is within easy reach of the Lift operator. It must be clearly and legibly marked to indicate its purpose.

The figure to the right shows a toggle Power Disconnect Switch between the Lift's power source and its Power Unit. A quick flip of the switch immediately cuts power to the Lift.

Make sure to have a licensed Electrician install the Power Disconnect Switch.

Make sure the Electrician installs a UL-listed Power Disconnect Switch.

Install a Thermal Disconnect Switch

⚠ WARNING The Lift's motor **does not** include thermal overload protection.

Connect a motor Thermal Disconnect Switch or overload device that will shut down the equipment in the event of an overload or an overheated motor.

⚠ DANGER A licensed Electrician must perform all wiring.

Electrical current that exceeds the motor's full load amperage rating (FLA) may result in permanent damage to the motor. BendPak strongly recommends you **not** exceed the rated duty cycle of the Lift's motor.

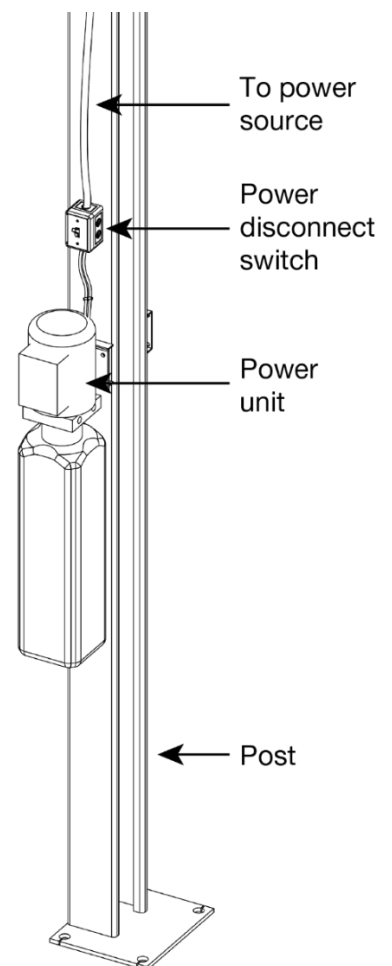

Lift Start-Up

1. Verify the Power Unit Reservoir has been filled with the appropriate hydraulic fluid and compressed air is supplied to the Lift.
2. Spray the inside of the Lift columns with a small amount of white lithium grease.
3. Test the Power Unit by pressing the Up Button. If the motor sounds like it is operating correctly, raise the lift and check all hose connections for leaks. If the motor becomes hot or sounds peculiar, stop, and check all electrical connections.
4. Before proceeding, verify all cables are running true in their cable sheaves and all sheave pins and retainers are secure.
5. Verify all Slack Safeties are clear and free.
6. Press the Up Button until the cable slack has been taken up, and the Lift begins to move.
7. Raise the Lift Runways until the Lift Stops, then lower until the safeties engage the top locking position.
8. Adjust each Safety Ladder by tightening or loosening the Safety Ladder Nut until all four Safety Locks are resting in the Top Lock Position.
9. Tighten each Cable Nut until all four Safety Locks are at least one inch above the Top Lock Position. At least one inch of thread must protrude through the nut.

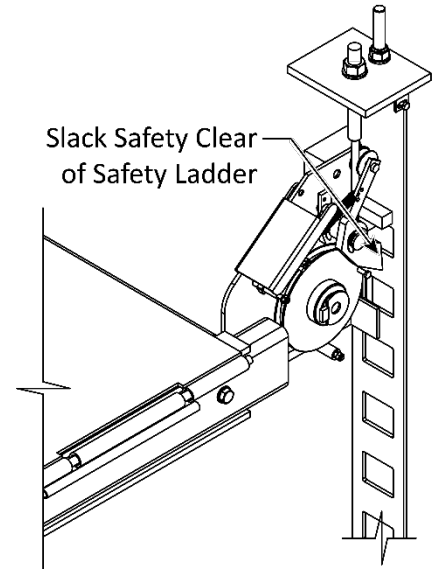

⚠ DANGER All cable nuts must be tightened on each post as in step 9 above. Failure to do so can result in severe injury or death.

IMPORTANT: There will be an initial stretching of the cables with increased loads. Adjust the Cables as outlined above about one week after first use, then check and adjust every three to six months as required to compensate for stretching.

8. To Lower the Lift, press the Pushbutton Air Valve and the Lowering Valve on the Power Unit simultaneously.

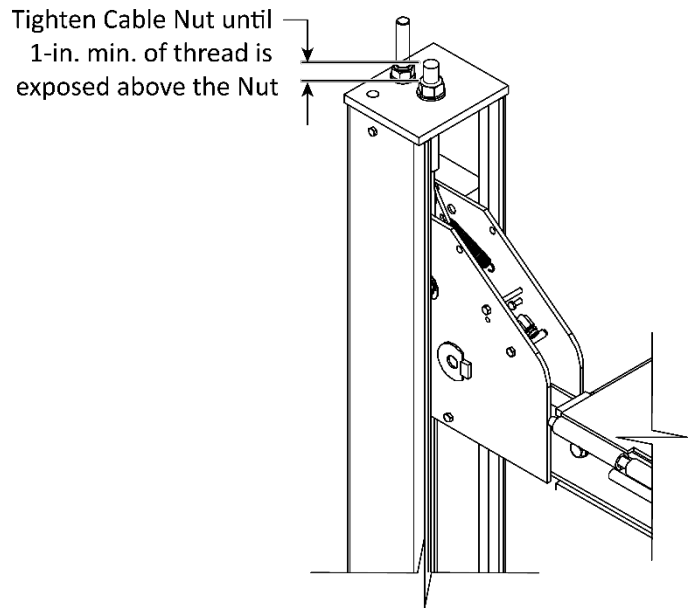

Anchor the Posts

Anchor each of the Lift's four Posts. Install one Anchor Bolt in each corner of each Base Plate, 16 Anchor Bolts total.

About Effective Embedment

Anchor Bolts achieve their holding strength from the depth at which the Anchor Bolt's Expansion Sleeve presses into the Concrete (Effective Embedment) and how forcefully the Expansion Sleeve presses into the Concrete (based on the width of the hole and Torque applied).

The deeper the Expansion Sleeve, the greater the Effective Embedment, thus the greater the holding strength of the Anchor Bolt. The hole should be drilled at the same diameter as the Anchor Bolt with no wobbling. The correct amount of Torque is a small range; exceeding the recommended Torque value may damage the concrete and reduce the Anchor Bolt's holding strength.

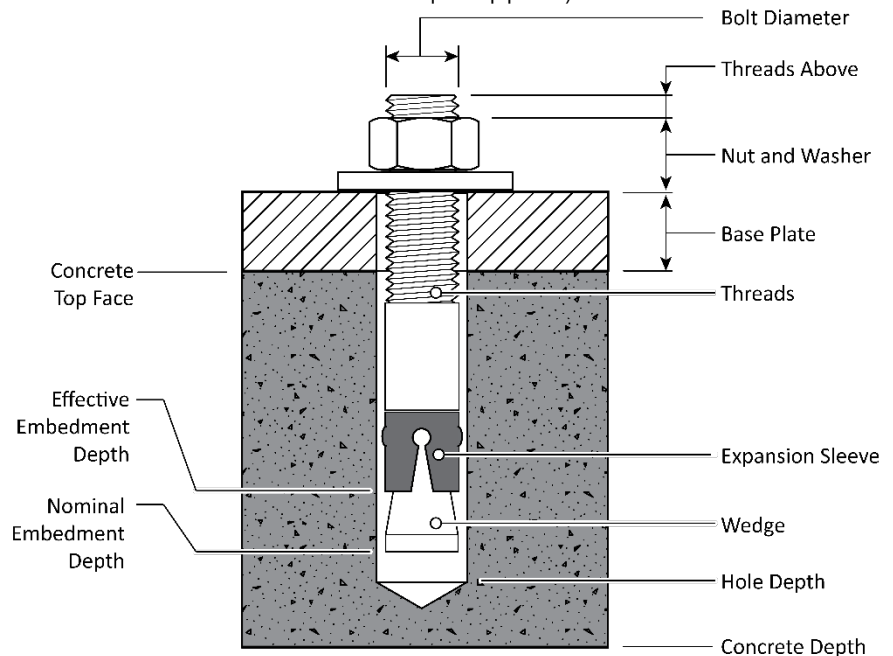

Note: Do not confuse Effective Embedment with *Nominal* Embedment, which is how far down into the Hole the *bottom* of the Anchor Bolt is. The two are **not** the same; Nominal Embedment does not tell you anything about the holding strength of the Anchor Bolt. carefully follow the specifications and instructions in [Anchoring the Posts](#).

⚠ WARNING Use only the Anchor Bolts delivered with your Lift. Only install your Lift on a Concrete floor. Make sure there is the correct amount of Effective Embedment and use the correct amount of Torque.

Install the Anchors

Concrete specifications:

- **Depth:** 4.25 in (108 mm)
- **Compressive Strength:** 3,000 PSI, min.
- **Cured:** 28 days, minimum

Anchor Bolt specifications:

- **Length:** 4.75 in (120.5 mm)
- **Diameter:** .75 in (19 mm)
- **Anchor Torque:** 85 – 95 lb.-ft.

⚠ WARNING Your Concrete and Anchor Bolts **must** meet these specifications. Only install your Lift on a Concrete surface. If you install a Lift on asphalt or any other surface, or your Concrete or Anchor Bolts do not meet these specifications, it could lead to product damage, Vehicle damage, personal injury, or even loss of life.

BendPak Lifts are supplied with installation instructions and Concrete fasteners meeting the criteria as prescribed by the current version of the American National Standard “Automotive Lifts – Safety Requirements for Construction, Testing, and Validation” ANSI/ALI ALCTV.

⚠ WARNING Use only the Anchor Bolts delivered with your Lift. If you use components from a different source, you void your warranty and compromise the safety of everyone who installs or operates the Lift.

Lift buyers are responsible for conforming to all regional, structural, and seismic anchoring requirements specified by any other agencies and/or codes, such as the Uniform Building Code and/or International Building Code.

Be sure to check your concrete floor to determine if it is a **post-tension slab**. In this case, you must contact the building architect or the local building and safety department before drilling. Using ground penetrating radar may be required to find the tensioned steel.

⚠ WARNING Cutting through a tensioned cable can result in injury or death. Do not drill into a post-tension slab unless the building architect confirms you are not going to hit tensioned steel, or you have located it using ground penetrating radar. **If a colored sheath comes up during drilling, stop drilling immediately.**

If the existing concrete floor does not meet the minimum requirements **BendPak strongly recommends consulting a Concrete Specialist early in your planning process for the Lift installation.** The recommendations presented in this manual are generic in nature and cannot cover all situations. A Concrete Specialist will adjust these recommendations to account for national, state, and local building codes as well as local weather conditions, soil composition, base preparation, load bearing, seismic requirements and any other structural concerns that may arise.

To anchor the Posts:

1. Retrieve the Anchors required: Four Anchor Bolts, four Nuts, and four washers **per Post**.
2. Using the Base Plates as guides, drill the holes for the Anchor Bolts—one hole in each corner of the Base Plate, to have four holes total per Base Plate. Use a hammer drill and a masonry drill bit (conforming to ANSI B212.15).

Do not drill all the way through the concrete. Drilling completely through the slab could compromise the holding strength of the anchor bolts.

The diameter of the drill bit must be the same as the diameter of the anchor bolt. If you are using a ¾ inch diameter anchor bolt, use a ¾ inch diameter drill bit. Ensure the drill flutes are at least as long as the depth of the hole to effectively remove material as you drill.

Drill a pilot hole! Pilot holes allow straighter, cleaner drilling by removing the material directly from the center of the final drill. This reduces the amount of force required to keep the drill straight and perpendicular to the floor.

If the drill hits rebar embedded in the concrete and has not ruined the Anchor Hole by making it too big or out of round, switch to a

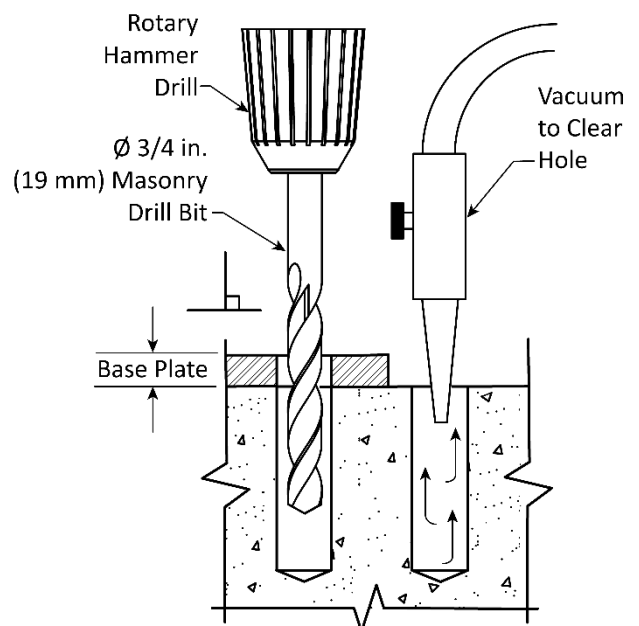

rebar cutting drill bit. Slow the drill speed to avoid overheating the drill bit. Continue drilling until you are past the Rebar. Do not rush the drilling operation. Pull the drill out of the hole frequently to remove debris from the hole.

Important: The holding strength of an Anchor Bolt is partially based on how cleanly the Expansion Sleeve presses against the Concrete. If the hole is dirty, the Expansion Sleeve does not press cleanly against the concrete. If the hole is too wide, the Expansion Sleeve does not press with as much force. Both result in less holding strength.

3. Vacuum each hole clean. BendPak recommends using a vacuum to clean the hole. A wire brush, hand pump, or compressed air may also be used; just **make sure to thoroughly clean each hole.**
4. Plumb each Post; install any required Shims.

Do not shim a Post more than half an inch using the provided Shims. A maximum of 2 inches is possible by ordering optional Shim Plates. Contact BendPak at **(800) 253-2363**, select option 7 then 4 to order. Please have the model and serial number of your Lift available. Take your time while plumbing and shimming the Posts; **it is important to make the Lift as level as possible.**

5. Make sure the Washer and Nut are in place on the Anchor, **with the top of the Nut flush with the top of the Anchor Bolt**, then insert the Anchor Bolt into the hole.
6. Hammer or mallet the Anchor Bolt the rest of the way down into the hole. **Stop when the Washer is snug against the Base Plate.**

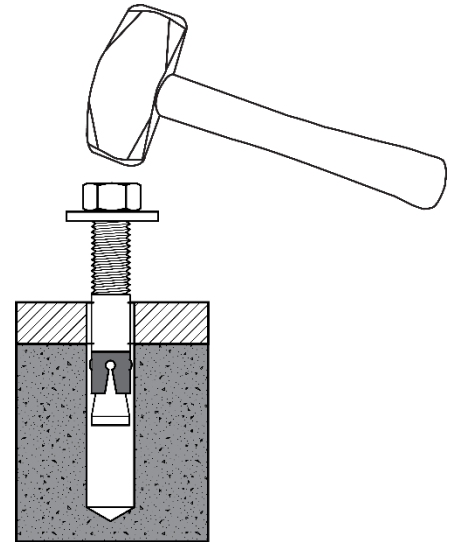

The Expansion Sleeve of the Anchor Bolt may prevent the Anchor Bolt from passing through the hole in the Base Plate too far; this is normal.

Even using a hammer or mallet, the Anchor Bolt should only go into the hole *part* of the way; this is normal. If the Anchor Bolt slides all the way in with little or no resistance, the hole is too wide. Once past the hole in the Base Plate, the Anchor Bolt eventually stops going down into the hole as the Expansion Sleeve contacts the sides of the hole; this is normal.

7. Torque each Nut **clockwise** to the recommended installation torque, 85 – 95 lb-ft, using a Torque Wrench.

Important: Do **not** use an impact wrench to torque the Anchor Bolts.

Do not torque in excess of 95 lb-ft; you could damage the Concrete. Tightening the Nut forces the Wedge up, forcing out the Expansion Sleeve and pressing it tightly against the Concrete.

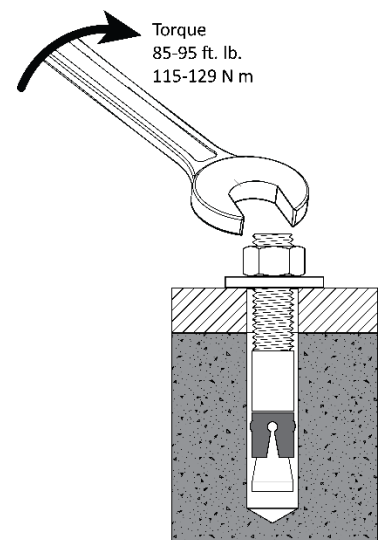

Final Leveling

It is very important that the Lift's Runways are level, or as close to level as possible. The following procedure describes how to fine tune the level of the Lift. The goal is hear the four Safety Locks on the Lift engage at the same time.

To complete a final leveling on the Lift:

1. Raise your Lift to the first Safety Lock position (the Primary Safety Locks, not the Slack Safety Locks).
2. Use a transit level or other leveling mechanism to evaluate how level the Posts and Runways are to each other.
3. With the Platforms at rest on the Safety Locks. Tighten each Lifting Cable until the platform just moves a bit on the Safety Lock.
4. If you need to adjust a Runway, loosen the stop nut and use the Top Nut on the Top Cap of each Post to adjust the Ladder in that Post up and down (which impacts the level of the Runway and when the Safety Locks engage).
5. Raise the Lift to full height, listening as the Safety Locks engage.

If you hear the Safety Locks engaging at the same time, no further adjustments are necessary.

If the Safety Locks are not engaging at the same time, check the leveling, make necessary adjustments, and then raise the Lift again and listen as the Safety Locks engage.

6. When you are satisfied the Lift is level, firmly secure the Safety Ladder Nuts and stop nuts at the top of each Post.

Install Accessories

The accessories available for this Lift include:

- **Gusset Covers.** Yellow, Plastic Covers that are installed on top of the Crosstube Gussets.
- **Tire Stops.** Installed at the Front of the Lift. Holds the Tires of the Vehicle in position. BendPak recommends chocking the rear Tires, so that the Vehicle stays in place. Included with the Lift.
- **Ramps.** Installed at the Rear of the Lift. Allows Vehicles to be easily driven onto the Runways. Included with the Lift.
- **Anti-Slip Tape.** Designed to increase friction between the metal surface of the Lift Ramps and Vehicles or personnel on the Lift.
- **Caster Kit.** (Purchased separately). Allows the Lift to be moved to another location.

Boat Trailer Tongue Platform

The Trailer Tongue Platform is included with the HD-7500BLX and HD-75BXT only. The trailer Tongue Platform is available as optional equipment for the HD-7500PBX.

The Boat Trailer Tongue Platform extends apart 20 inches, from 48 to 68 inches between the Runways.

The Boat Trailer Tongue Platform can support up to 3,000 lbs.; do **not** exceed the rated capacity.

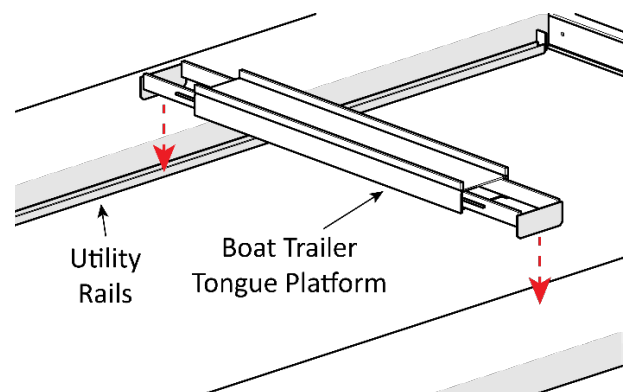

To install the Boat Trailer Tongue Platform:

1. With no vehicles or trailers parked on the lift, retrieve the Boat Trailer Tongue Platform.
2. Adjust the Boat Trailer Tongue Platform's, Extendable Bases outward to the approximate width so that they will securely rest on the Utility Rails (inside edges of Runways). Next, accurately set the Boat Trailer Tongue Platform onto the Lift's two Utility Rails and to the approximate area (fore and aft) where the trailer's jack will be lowered.
3. With the tow vehicle safely attached, back the boat and trailer onto the lift and into a proper and safe parking position on the runways. Place the tow vehicle's transmission in Park (in gear for manual transmissions), turn off the tow vehicle's engine, and fully apply the parking brake. With the boat trailer remaining hitched to the tow vehicle, chock the boat trailer's wheels so that they cannot roll either forward or rearward on the runways.
4. Slide the Boat Trailer Tongue Platform into position so that when the trailer's jack is lowered, it will stand centered on the Tongue Platform. Release the trailer's tongue coupler and then jack the boat trailer up above the tow vehicle's hitch. With the boat trailer's tongue free from the tow vehicle's hitch, remove all safety chains and wiring harnesses between the tow vehicle and the boat trailer. Move and park the tow vehicle safely away from the boat trailer. Lower the Boat Trailer's tongue jack so that the boat trailer is now resting approximately level. Stow safety chains and wiring harnesses.
5. The boat trailer's wheel chocks are to remain in place the entire time the trailer is parked on the lift.

Gusset Covers

Gusset Covers are installed on top of each Crosstube Gusset. 4 Gusset Covers total.

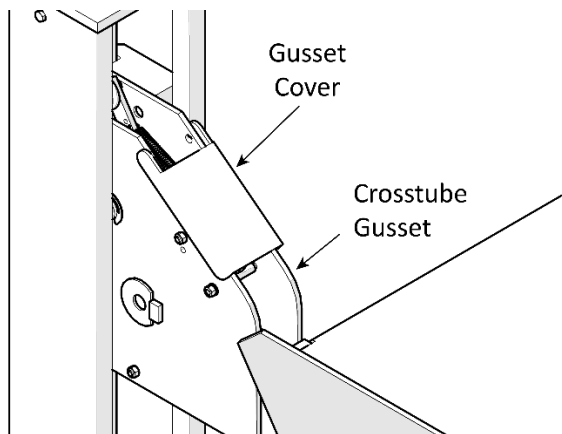

To install the Gusset Covers:

1. Locate the four Plastic Covers from the Parts Box that came with your Lift.
2. Align the Covers with the openings in the Gusset, one at each end of the Crosstube, then push each Cover into place.
Repeat for the remaining covers.

Tire Stops

Tire Stops are attached on the Front of the Lift. They prevent the tires of the Vehicle on the Lift from travelling too far forward.

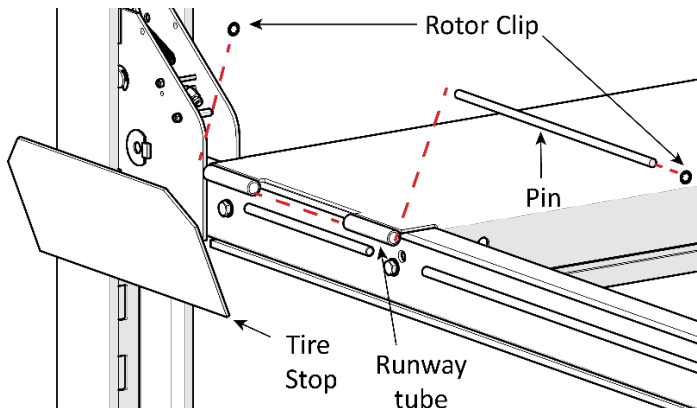

To install the Tire Stops:

1. Locate the two Tire Stops, two Tire Stop Pins, and four Rotor Clips.
2. Put one Tire Stop in position between the Tubes attached to the Runway, then put the Tire Stop Pin all the way through the Tire Stop and the Tubes.
3. Secure the Tire Stop with Rotor Clips on each end of the Tire Stop Pin.
4. Repeat Steps 2 and 3 for the second Tire Stop.

Ramps

The Lift includes two steel Drive-Up Ramps, for driving Vehicles onto the Runways.

To install the Ramps:

1. Locate the two Drive-Up Ramps, two Ramp Pins, and four Rotor Clips.
2. Place a Ramp into position on the end of a Runway at the Rear of the Lift, with the Tube on the bottom of the Ramp between the two Tubes on the end of the Runway.
3. Slide a Ramp Pin through the three Tubes, then install Rotor Clips on both ends of the Ramp Pin.

Note: The Ramps are heavy and awkward, BendPak recommends having two people install them; one to hold the Ramp, the other to put the components into place.

4. Repeat Steps 2 and 3 for the remaining Ramp.

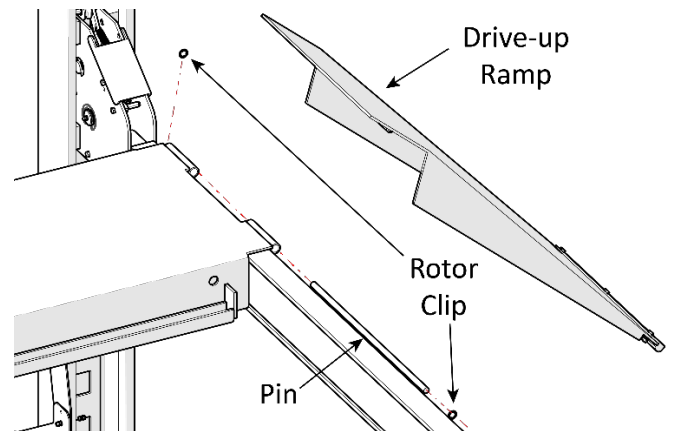

Anti-Slip Tape

Anti-Slip Tape is designed to increase friction between the metal surface of the Lift Ramps and Vehicles or personnel on the Lift. The Anti-Slip Tape is provided in a single roll measuring 6 in. x 24 ft. (152 mm x 7.3 m). BendPak suggests cutting the Tape into four equal lengths 72 in. (1,829 mm) long.

IMPORTANT!

Surface preparation is critical. Lift Runways must be clean, dry, and smooth. No grease or oil should be on the surface. If the runway is in poor condition with gouges, holes, or jagged edges, the Anti-Slip Tape will not adhere.

To apply the Anti-Slip Tape:

1. Clean the runway. Use a broom or brush to remove loose dirt and debris from the runway.
2. Thoroughly wash, rinse, and dry the runway using a mild solution of soap and clean water to remove any oils, grease, and water-soluble contamination. Dry the runway with a clean cloth and allow to air dry.
3. Cut the Anti-Slip Tape into four equal sections. Suggested length is 72 in. (1,829 mm).
4. Verify the Runway is dry and clean. It is critical for maximum adhesion of the Anti-Slip Tape that the runway be dry, free of dirt, oils, and grease.
5. Measure and mark the runways with pencil guidelines to outline the tape installation area on the ramp. Refer to the figure on the next page for a suggested layout of the Anti-Slip Tape.

IMPORTANT!

Do not install this Tape directly on the edge of a Runway. Stay at least 1 in. (25 mm) away from edges. Do not attempt to bend the Tape over an edge.

6. Wash your hands. The Anti-Slip Tape's adhesive side is protected by a paper or plastic film. You will remove this film a few inches at a time to apply the Tape to the Runway.

IMPORTANT!

Handle the Anti-Slip Tape by its edges. Minimize contact between the adhesive and your hands. The oils from your hands will reduce the adhesive's long-term effectiveness.

IMPORTANT!

BendPak recommends two people work together to install the Tape. One person removes the backing and applies the Tape to the Runway while the second holds the Tape in place over the guidelines marked on the Runway.

7. Lay one section of the Anti-Slip Tape on the runway and peel back about 2 inches (50 mm) of the protective film. Apply the adhesive side to the Runway inside the guidelines you created in step 5.
8. Slowly remove the film as you press the exposed Tape's adhesive side into the Runway. Work slowly and apply 2 to 5 inches at a time to stay within your guidelines.
9. After applying the Tape use a heavy rubber roller to press the Tape onto the Runway and to ensure firm contact with the adhesive.
10. Apply the Anti-Slip Tape to the remaining area of the Lift's runways. Refer to the figure on the next page.

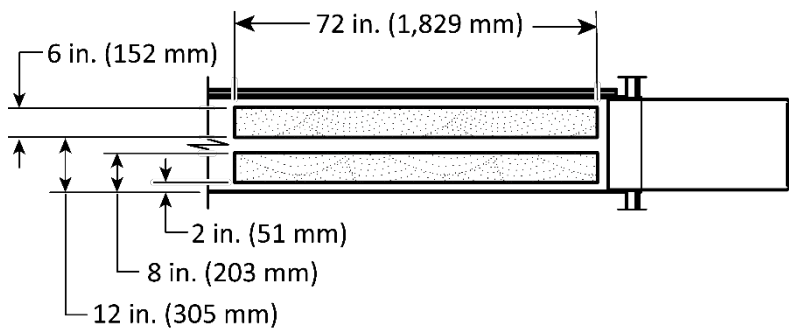
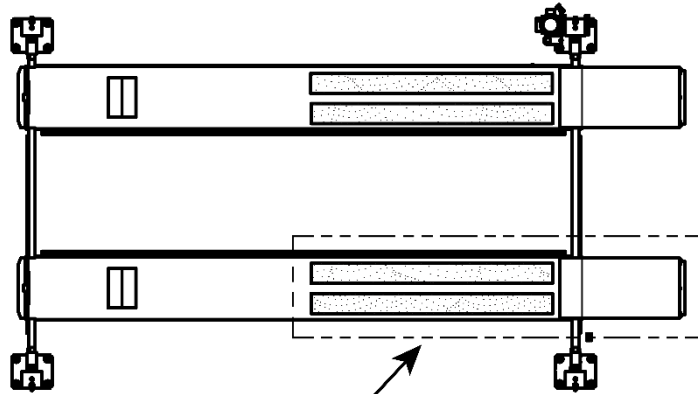
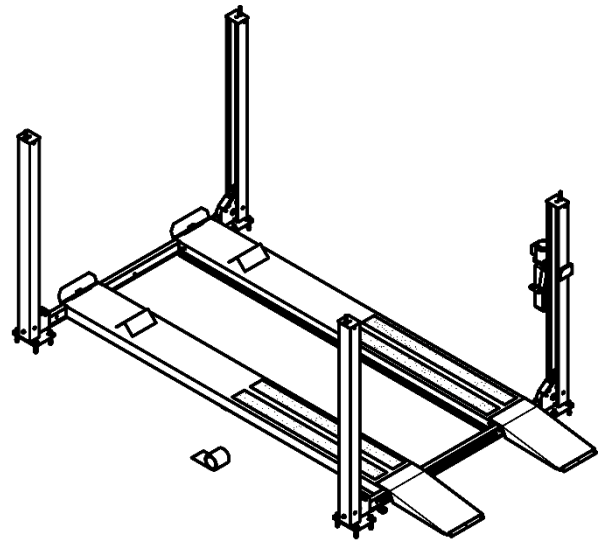

Caster Kit

The Caster Kit is an accessory option (purchased separately) and includes four assemblies, each of which installs under one of the Lift's four Posts. When the Lift is raised by the Caster Kit assemblies, you can move it to the desired location.

Important: When the move is complete, remove the Caster Kit assemblies. Do not leave the Caster Assemblies in place while operating the Lift.

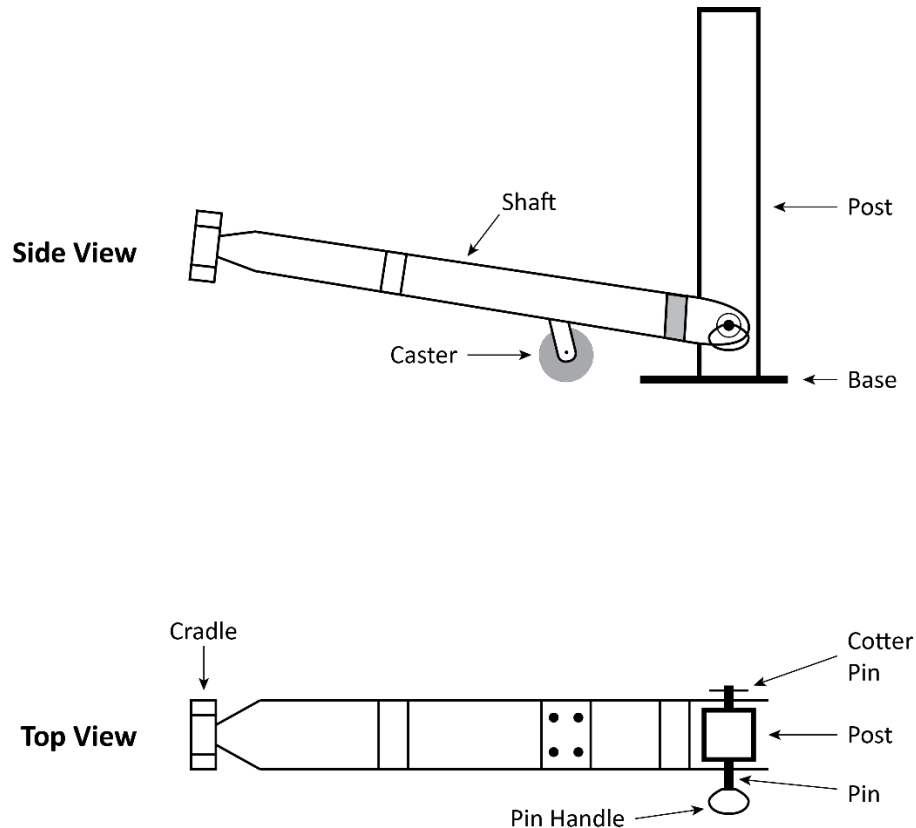

To move your Lift with the Caster Kit:

1. Raise the Lift to the first Safety Lock and engage it.
2. Locate the components of the four Caster Kit assemblies.
3. Using the supplied hardware, bolt the four Casters to the four holes in the four Caster Kit Shafts.
4. Take one Shaft and put the open end around the Post, with the Shaft on the inside of the Lift.
The Cradle of the Shaft needs to be directly below the Crosstube.
5. Put the Pin through the holes in the Caster Kit assembly and the Post.
6. Put the Cotter Pin into place on the end of the Pin.
7. Repeat Steps 4 through 6 for the other three Caster Kit Assemblies.
8. Lower the Lift to the ground.
Make sure the Crosstubes are going into all four Cradles on all four Caster Kit Shafts; this is what pushes the Bases of the Posts off the ground so that you can move it.
9. Move the Lift to the desired location.
10. Raise the Lift to a locking position and engage it there.
11. Take off all four Caster Kit assemblies.

Lubricate the Lift

All Cable Sheaves, Pins, and Boat Trailer Tongue Platform Ends, require occasional lubrication with an adequate quantity of Red Lithium Grease. Repeat monthly or as required.

Apply a small amount of White Lithium Grease or similar on the inside of the Lift Posts where the Slide Blocks travel up and down. Repeat monthly or as required.

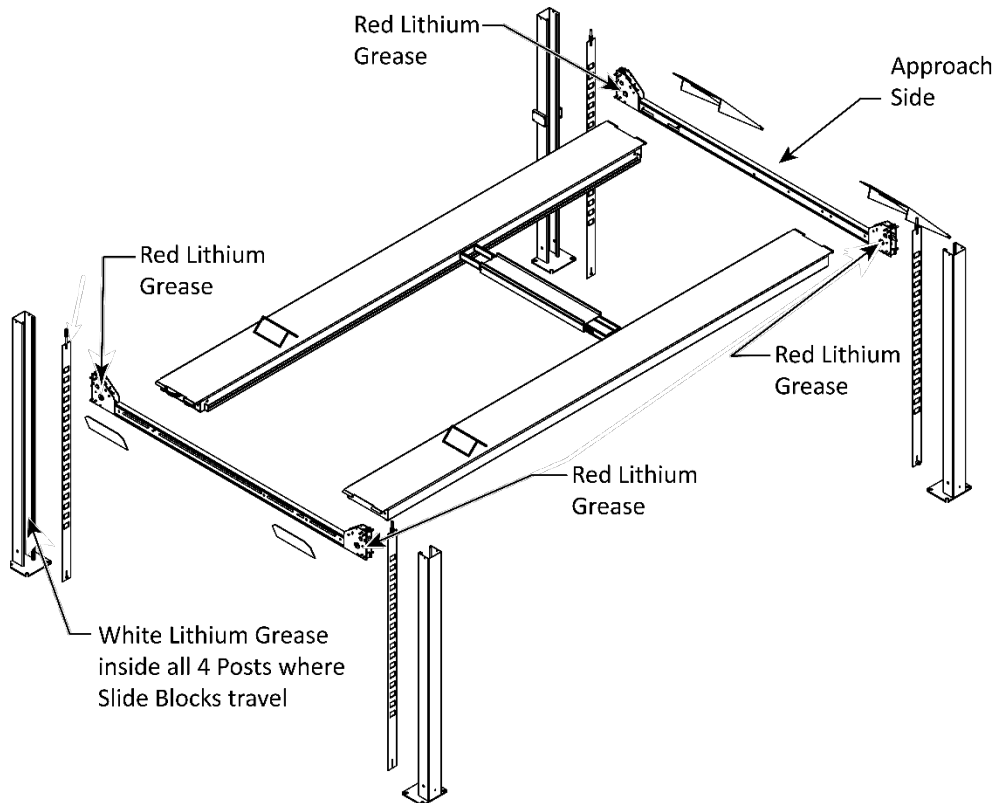

Perform an Operational Test

BendPak strongly recommends performing an Operational Test of the Lift with a typical Vehicle before beginning routine use (a typical Vehicle is not required but is recommended).

 **DANGER** Remember that lifting a Vehicle is a serious endeavor with life-threatening risks. Focus on what you are doing. Automotive Lifts are dangerous when used by inexperienced or impaired operators. **Do not assume you are going to be safe this time because nothing happened last time.**

During the Operational Test, watch the Lift and its components and check for proper installation and operation. If you run into an operational issue, refer to **Troubleshooting** for more information.

Note: Residual air in the Hydraulic System can sometimes cause the Lift to shake, move erratically, or squeak during initial use. If this occurs, it may dissipate as the Hydraulic System is self-bleeding. If it does not dissipate, bleeding the Cylinder of air may correct the issue. Otherwise, refer to **Troubleshooting** for additional information or call Customer Support, **(800) 253-2363** select option 7, then 5.

To test your Lift:

1. Check the area around, above, and under the Lift for obstructions; *Remove any obstructions.*
2. Drive a Vehicle onto the Lift. Try to center the Vehicle's tires in the middle of each Runway.
3. Put the Vehicle into park, apply the parking brake, shift into gear (manual transmission).
4. Exit the vehicle and chock the wheels.
5. Press and hold the Up button; both Runways begin to rise.
6. After the Runways pass one or two Safety Locks (you will hear them as they pass), release the Up button; the Runways stop rising.
7. Press **and hold** the Pushbutton on the Pushbutton Air Valve, then press **and hold** the Lowering Handle; the Runways start lowering.
8. When the Runways reach the ground, release the Pushbutton and the Lowering Handle.
9. Wait for one minute.

 **CAUTION** Always take a break between lift cycles. The Power Unit's motor is **not** rated for constant duty.

10. Repeat the process, this time raising the Runways to a higher Safety Lock.
11. If the Lift is working without shaking, moving erratically, or squeaking, there is no need to repeat the procedure.

If the Lift is shaking, moving erratically, or squeaking (which is common during the start-up period), repeat the procedure a couple more times, with at least a one-minute break between cycles.

If you continue to have issues, refer to **Troubleshooting** for assistance.

Review the Final Checklist

Make sure these things have been done **before** putting the Lift into service:

- Review the **Installation Checklist** to make sure all steps have been completed.
- Verify the Power Unit is getting power from the power source.
- Check the Hydraulic Fluid reservoir on the Power Unit; it must be full of approved Hydraulic Fluid or automatic transmission fluid. **You can damage the motor by running it without enough fluid.**
- Check the Hydraulic System for leaks.
- Make sure all four Posts are properly anchored, shimmed, level, and stable.
- Make sure all Lifting Cables are properly seated in their Sheaves.
- Make sure all Safety Locks are operating normally.
- Make sure the Slack Safety Locks are **not** engaged.
- If it has not been done already, perform an Operational Test of the Lift with a typical Vehicle. Refer to **Performing an Operational Test**.
- Make sure a copy of the *Installation and Operation Manual* remains with the Lift.

Operation

This section describes how to operate your automotive Lift.

⚠ DANGER Remember lifting a Vehicle is a serious endeavor with life-threatening risks. Focus on what you are doing. Automotive Lifts are dangerous when used by inexperienced or impaired operators. **Do not assume you are going to be safe this time because nothing happened last time.**

⚠ DANGER **Crushing hazard and pinch points.** Do not place any part of your body between the top deck and any moving part of the Lift unless visual confirmation is made that the safety lock is fully engaged, and that the Lift's downward motion is blocked by a Jack Stand, Forklift or other Load-Holding device that will prevent the Lift's downward movement while working under it.

Safety Considerations

⚠ WARNING Your safety is dependent on reading, understanding, and implementing these Safety Rules. **Do not skip over them—read them carefully and follow them; your life may depend on it!**

⚠ WARNING **Slippery When Wet** Any wet lift surfaces or adjacent wet concrete areas, create slipping hazards for both personnel and moving vehicles. Use extreme caution around all wet areas.

Do the following **before** you raise a Vehicle on your Lift **every time**:

- **Check the Lift.** Walk all the way around the Lift, checking for any missing, heavily worn, or damaged parts. Use caution when driving a Vehicle onto wet or icy Drive-up Ramps or Runways; **do not** walk on Lift surfaces that are wet or icy. Do not operate the Lift if you find any issues; instead, remove it from service, then contact your dealer, email support@bendpak.com, or call **(800) 253-2363** select option 7, then 4.
- **Check the area.** Keep the area around, above and under the Lift clean and free of obstructions; anything that could cause a problem. Do not forget to check **above** the Lift. If you find an obstruction, move it out of the way. If you find any other issues, resolve them before using the Lift. *Do not allow people or animals within 30 feet of the Lift while it is moving.*
- **Check the operators.** Make sure everyone who is going to operate the Lift has been trained, has read the labels on the unit, and has read the manual. Only the operator at the Controls should be within 30 feet of the Lift while it is moving.

Do not allow children to operate the Lift. Do not allow anyone under the influence of drugs, alcohol, or medication to operate the Lift. Do not allow any unauthorized personnel to operate the Lift. Operators should wear non-skid, steel toe footwear and safety glasses when operating the Lift.

- **Check for safety.** Make sure everyone who is going to be walking near the Lift is aware of its presence and takes appropriate safety measures. Only put Vehicles on the Runways. When raising a Vehicle, do not leave it until it is engaged on Safety Locks. When lowering the Lift, do not leave it until it is on the ground.
- **Check the Vehicle.** Never exceed the Lift's weight rating. Do not allow people inside a Vehicle you are going to raise. Make sure the Vehicle is not overbalanced on either end or side.

Using the Controls

The Controls for the Lift include:

- **Up button.** Press and hold to raise the Runways. Located near the top of the Power Unit.

To put Runways onto a Safety Lock position: Raise the Runways a little above where you want them, then press and hold the Lowering Handle to lower the Runways onto the Safety Locks (*do not* press and hold the pushbutton on the Pushbutton Air Valve). When the Runways stop going down, they are engaged on a Safety Lock.

Before leaving the Lift, make sure all four corners are engaged on Safety Locks at the same height.

- **Lowering Handle.** Press and hold to lower the Runways. Located in the middle on the Power Unit.

To lower raised Runways down to the ground, press and hold the Up Pushbutton for a couple of seconds. Then **push and hold** the Air Valve Pushbutton while **pressing and holding** the Lowering Handle.

Watch the Runways as they descend to make sure they are coming down evenly. If they are not, stop lowering the Lift and troubleshoot the problem.

⚠ WARNING Only leave the Lift engaged on its Safety Locks or fully lowered.

- **Pushbutton Air Valve.** Press and hold as part of the process to lower the Runways. Located on one side or the other of the Power Unit (depending on where it was installed). Pressing and holding the pushbutton on the Pushbutton Air Valve disengages the Safety Locks, which is needed to lower the Runways.

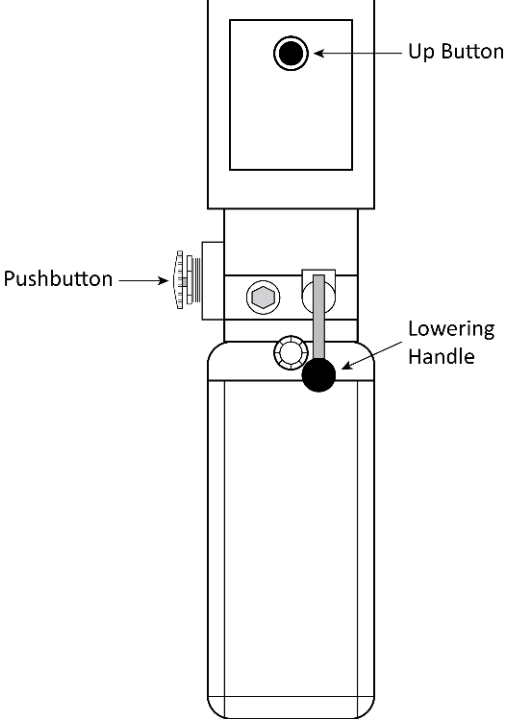
<p>To raise Runways and engage them on Safety Locks:</p> <ol style="list-style-type: none">1. Press and hold Up Button.2. When just past desired height, release Up Button.3. Press and hold Lowering Handle.4. Runways stop going down when engaged on Safety Locks; release Lowering Handle when they stop. <p><i>Do not press and hold Pushbutton.</i></p> <ol style="list-style-type: none">5. Make sure all four Posts are engaged at same height.	 <p>The diagram shows a vertical control panel. At the top is a rectangular box containing a circular 'Up Button'. Below this box is a 'Pushbutton' with a textured surface. Further down is a 'Lowering Handle' which is a vertical rod with a circular grip at the bottom. Arrows point from the text labels to their respective components in the diagram.</p>	<p>To lower Runways:</p> <ol style="list-style-type: none">1. Press and hold Up Button for a couple of seconds; this moves Lift off Safety Locks.2. Press and hold Pushbutton.3. Press and hold Lowering Handle. Runways begin lowering.4. When Runways are fully lowered (on ground), release Pushbutton and Lowering Handle.
---	---	--

Raising and Lowering Vehicles

Keep the following in mind when operating your Lift:

- **Be safe.** Make sure to check for people, pets, and objects that might be in the path of the Lift as you raise or lower it. If there is something in the way, stop the Lift and move it out of the way. Watch the Lift carefully as it raises and lowers.
- The Operator should have a clear unobstructed view of the Lift at all times.

 **DANGER** Pay careful attention when you are raising or lowering your Lift. If a person or pet becomes stuck under the Lift, they could be injured or in rare cases, killed. If a problem occurs, immediately stop the Lift, and safely clear the area of the person or pet.

- **The Power Disconnect Switch is important.** If something unexpected happens, use the **Power Disconnect Switch** to immediately stop the Lift from moving.
- **Remove needed items from the Vehicle or Boat Trailer before lifting it.**
- **Never raise your Lift with anyone in the Vehicle.**
- **Make sure the Vehicle or Boat Trailer is balanced.** If there is extra weight on one end or the other, remove it or balance the vehicle's placement before raising.
- **Center the Vehicle's wheels on the Runway.** Centered wheels keep the Vehicle balanced.

To raise a Vehicle or a Boat Trailer:

1. Make sure the Runways are on the ground. If they are not, move them down to the ground.

2. Drive a Vehicle onto the Runways.

Verify all four wheels are fully on the Runways, as close to the center of the Runways as possible.

Put the Vehicle into park and apply the parking brake. If it is a manual transmission, make sure it is in a gear, not in neutral and always **Chock the tires.**

3. Press the Up button on the Power Unit.

The Runways begin to rise.

4. When the Runways reach the desired height, move runways up a little more, then release the Up button. Press and hold the Lowering Handle.

The Runways Safety Locks will engage on the most recently passed Safety Lock.

If one of the four Safety Locks has not engaged, the non-engaged corner of the Lift will continue to lower, while the others stay where they are. This results in a Runway that is not level.

Always verify that all four Safety Locks are engaged at the same height before working under or near a raised vehicle.

 **WARNING** Only leave your Lift engaged on Safety Locks or fully lowered.

5. With the Runways engaged on the Safety Locks, check around the Vehicle to make sure there are no obstructions, and both ramps are resting on Safety Locks.

If you see anything wrong, fix it before anyone works near the Runways.

To lower a Vehicle or Boat Trailer:

 **DANGER** **Crushing hazard and pinch points.** Do not place any part of your body between the top deck and any moving part of the Lift unless visual confirmation is made that the safety lock is fully engaged, and that the Lift's downward motion is blocked by a Jack Stand, Forklift or other Load-Holding device that will prevent the Lift's downward movement while working under it.

1. Verify there are no obstructions near or under the Runways you are about to lower.
If there are, move them out of the way before lowering the Runways.
2. Verify there are no personnel within 30-feet of the Lift.
3. Press and hold the Up Button for a couple of seconds.
This action moves the Lift off the Safety Locks on which the Runways rested.
4. Press and hold the Pushbutton on the Pushbutton Air Valve while pressing and holding the Lowering Handle.
The Runways will begin to lower.
5. When the Runways are fully lowered (on the ground), release the Air Pushbutton and the Lowering Handle.
6. Remove the Tire Chocks.
7. Remove the Vehicle or Boat Trailer off the Runways when the path is clear and safe.

Maintenance

 **DANGER** Before performing maintenance on your Lift, verify it is disconnected from power. The Lift uses electrical energy; if your organization has Lockout/Tagout policies, make sure to implement them before performing any maintenance. If you come into contact with high voltage/current, you could be injured or killed.

To maintain your Lift:

- **Daily:** Keep the Lift clean. Wipe up any spills, remove any dirt.
- **Daily:** Make a visual inspection of all moving parts and check for damage or excessive wear. Replace any damaged or worn parts before using the Lift.

 **DANGER** Do not use the Lift if the Lifting Cables are damaged or extremely worn. If a Vehicle is raised when you notice the damage or extreme wear, very carefully lower the Vehicle to the ground. When the Lift is on the ground, take it out of service, disconnect it from power, and make arrangements for repair or replacement.

 **DANGER** **Crushing hazard and pinch points.** Do not place any part of your body between the top deck and any moving part of the Lift unless visual confirmation is made that the safety lock is fully engaged, and that the Lift's downward motion is blocked by a Jack Stand, Forklift or other Load-Holding device that will prevent the Lift's downward movement while working under it.

 **WARNING** **Slippery When Wet** Any wet lift surfaces or adjacent wet concrete areas, create slipping hazards for both personnel and moving vehicles. Use extreme caution around all wet areas.

- **Daily:** Verify all Safety Locks are in good operating condition. Do not use your Lift if the Safety Locks are damaged or excessively worn.
- **Monthly:** Check all labels on the Lift. Replace any that are illegible or missing.
- **Monthly:** Grease the lubrication points on the Lift. Use white lithium grease or similar on the inside of the Lift Posts. Use Red Lithium Grease on the Sheave Pins and Bearings.
- **Monthly:** Check Hydraulic Fluid levels. Refill if low.
- **Monthly:** Lubricate the wire rope (Lifting Cables). Use a wire-rope lubricant such as 90-WT gear oil or ALMASOL® Wire Rope Lubricant.
- **Monthly:** Check cable connections, bolts, and pins for proper mounting and torque.
- **Every two months:** Check all Anchor Bolts to verify they are properly torqued. If they are loose, tighten them.

 **WARNING:** Do not operate your Lift if you find maintenance issues; instead, take the Lift out of service, then contact your dealer, visit bendpak.com/support, email support@bendpak.com, or call **(800) 253-2363**, select option 7 then 4.

Wire Rope Inspection and Maintenance

The Lifting Cables, are wire rope and should be inspected regularly:

- Wire rope should be replaced when there are visible signs of damage or extreme wear. *Do not use the Lift if it has damaged or worn Lifting Cables; **take it out of service!***

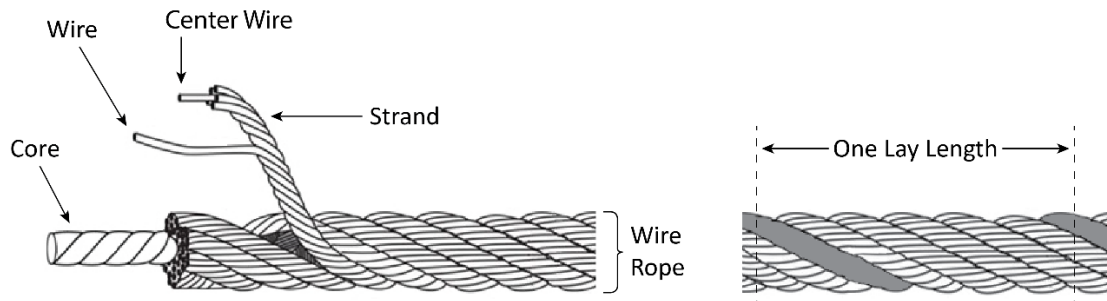

- Wire rope should be maintained in a well-lubricated condition at all times.
Wire rope is only fully protected when each wire strand is lubricated both internally and externally. Excessive wear shortens the life of wire rope. Use a wire-rope lubricant that penetrates to the core of the rope and provides long-term lubrication between each individual strand, such as 90-WT gear oil or ALMASOL® Wire Rope Lubricant. To make sure the inner layers of the rope remain well lubricated, lubrication should be done at least every three months during normal operation.
- All Sheaves and guide rollers that contact moving wire rope should be given regular visual checks for surface wear and lubricated to make sure they run freely. This should be done every three months during normal operation.
For all Sheave axles, use standard wheel bearing grease. For all Sheaves and/or guide rollers, use 90-WT gear oil or a similar heavy lubricant, applied by any method including pump/spray dispensing, brush, hand, or swabbing.
- How often should you inspect?
Wire rope should be visually inspected at least once each day when in use, as suggested by American Petroleum Institute's Recommended Practice 54 guidelines. Any wire rope that meets the criteria for removal must be immediately replaced.
- When should you replace wire rope due to broken wires?
Wire rope should be removed from service if you see six randomly distributed broken wires within any one lay length (where a single strand makes a full turn around the rope) or three broken wires in one strand within one lay length.
- Are there other reasons to replace your wire rope?
Yes. Corrosion that pits the wires and/or connectors, evidence of kinking, crushing, cutting, bird-caging, or a popped core, wear that exceeds 10% of a wire's original diameter, or heat damage.
- How do you find broken wires?
 - a. Relax your rope to a stationary position and move the pick-up points off the Sheaves. Clean the surface of the rope with a cloth — a wire brush, if necessary — so you can see any breaks.
 - b. Flex the rope to expose any broken wires hidden in the valleys between the strands.
 - c. Visually check for any broken wires. One way to check for crown breaks is to run a cloth along the rope to check for possible snags.
 - d. With an awl, probe between wires and strands and raise any wires that appear loose.

Torque Chart

FASTENER TORQUE CHART													
Bolt Size (SAE)	Bolt Grade (SAE)	SAE Grade 0-1-2	SAE Grade 5	SAE Grade 8	Socket Head Cap Screw SAE Grade	Bolt Class (Metric)	Metric Class 4.6	Metric Class 8.8	Metric Class 10.9	Metric Class 12.9			
											Tightening Torque		
		Lubricated (ft-lbs)	Zinc Plated (ft-lbs)	Plain & Dry (ft-lbs)	Lubricated (ft-lbs)	Zinc Plated (ft-lbs)	Plain & Dry (ft-lbs)	Lubricated (ft-lbs)	Zinc Plated (ft-lbs)	Plain & Dry (ft-lbs)	Lubricated (ft-lbs)	Zinc Plated (ft-lbs)	Plain & Dry (ft-lbs)
1/4-20	M6 x1.0	2.3	2.6	3.0	5.8	6.6	7.7	8.3	9.4	11.1	9.7	11.0	13.0
5/16-18	M8 x 1.25	3.8	4.3	5.0	9.7	11.0	13.0	13.9	15.8	18.5	16.3	18.4	21.7
3/8-16	M10 x 1.50	10.8	12.3	14.4	27.9	31.6	37.2	39.9	45.2	53.2	46.7	52.9	62.2
7/16-14	N/A	24.0	27	30.0	35.0	42	50.0	55.0	59	70.0	61.0	68	76.0
1/2-13	M12 x 1.75	18.9	21.4	25.2	48.7	55.1	64.9	69.6	78.9	92.8	81.4	92.2	108.5
9/16-12	M14 x 2.00	30.2	34.2	40.2	77.8	88.1	103.7	111.3	126.1	148.4	130.0	147.4	173.4
5/8-11	M16 x 2.00	47	53	62	121	137	161	173	196	230	202	229	269
3/4-10	M18 x 2.50	65	73	86	167	189	222	239	270	318	279	316	372
7/8-9	M22 x 2.50	136	155	182	320	365	430	460	515	600	510	575	640

WARNING! Prior to installation, inspect all accompanying manuals, parts lists and catalogs to ensure you have all the necessary parts. Identify all fasteners and their proper torque settings as illustrated on this chart. Proper torquing practices cannot be over emphasized. Torque values are provided as a convenient method of achieving correct pre-loading of highly stressed fasteners. If the fasteners are not properly plated, the fastener threads are not clean and free of deformation, or are not properly lubricated, the correct fastener pre-load will not be achieved even though the given torque value is reached. For this reason, it is critical that all fasteners be inspected for proper plating, thread form and correctly lubricated prior to torquing. Failure to verify a fastener's serviceability or to correctly lubricate the fastener prior to assembly and torquing will result in the fastener not being properly pre-loaded and subsequent failure of the fastener may occur. The torque values can only be achieved if the nut (or tapped hole) has a proof load greater than or equal to the bolt's minimum ultimate tensile strength. Clamp loads estimated as 75% of proof load for specified bolts. Torque values are listed in foot-pounds. Torque wrenches should be calibrated on an annual basis. Never use an impact driver on a torque multiplier.

Troubleshooting

Note: If your Lift is not functioning correctly, you **must** remove it from service until it is repaired.

Unless stated otherwise, all maintenance may be performed by the owner/employer and does not require trained lift service personnel.

⚠ WARNING The Lift uses electrical energy; if your organization has Lockout/Tagout policies, make sure to implement them before performing any Troubleshooting.

Problem	Corrective Action
Runways do not raise or do not lower, once raised.	Make sure there is sufficient Hydraulic Fluid in the reservoir. Bleed air from the Hydraulic System. Make sure the Hydraulic Hose is not pinched or leaking. Make sure the Power Unit is receiving power. If the Hydraulic Fluid is dirty, replace it with clean fluid. Make sure the Lift is not overloaded. Contact BendPak Support bendpak.com/support , email support@bendpak.com , or call (800) 253-2363 .
Runways do not lower past the nearest Safety Lock when pressing and holding the pushbutton.	Problem with the Air Line; check to make sure all sections of the Air Line are connected and not leaking or pinched.
One corner of the Lift is lower than the other three corners.	The Safety Lock on the lower corner is not engaged. Raise the Runways up, then lower them down onto the Safety Locks. Check to make sure all four Safety Locks are engaged.
Runways move erratically or squeak when in use.	Move the Runways up and down a few times to flush any residual air from the Hydraulic System. Make sure to pause for at least two minutes between cycles.
Runways do not stay up.	Check for leaking Hydraulic Fluid. Make sure the Runways are engaged on their Safety Locks.
Motor not running.	Check the connection to the power source; make sure it is plugged in and of the appropriate voltage. Make sure the wiring is correct; check the wiring diagram.
Hydraulic Fluid is dirty.	Replace the dirty fluid with clean, approved Hydraulic Fluid, such as Dexron III, Dexron VI, Mercon V, Mercon LV, Shell Tellus S4 / S3 / S2, or comparable.
Runways make odd noises.	Lubricate the bushings on the Sheaves on the sides of the Crosstubes using white lithium grease. If the Lift is new, a break-in period may be needed; run the Lift several times each day. If the noises persist, contact BendPak Support.

If you continue to have issues with your Lift, take it out of service, then contact your dealer, go to bendpak.com/support, email support@bendpak.com, or call **(800) 253-2363**.

Bleeding the Hydraulic System

The Hydraulic System on the Lift is self-bleeding, which means that in most cases any air in the system can be removed by raising and lowering the Runways a few times; “bleeding” the Hydraulic System of the unwanted air.

 **WARNING** Before performing any maintenance on your Lift verify both Runways are on the ground and the power source has been disconnected.

Symptoms of air in the Hydraulic System include Runways moving erratically and/or making odd noises. These could be caused by other situations; refer to [Troubleshooting](#) for more information.

To bleed the Hydraulic System:

1. Raise and lower the Runways up to six times; **pause for at least one minute between each cycle.**

The Lift’s motor cannot run continuously; it is designed for regular use, but not continuous use.

2. Watch the Runways as you raise and lower them.

When the Lift stops moving erratically or stops squeaking, you can stop the bleeding process.

3. Check the Hydraulic Fluid reservoir on the Power Unit.

Bleeding the Hydraulic System may significantly lower the amount of Hydraulic Fluid in the reservoir.

4. Add additional Hydraulic Fluid if necessary.

If your Lift is still moving erratically or making odd noises after bleeding the Hydraulic System, refer to [Troubleshooting](#) for more information.

Wiring Diagrams

5585014

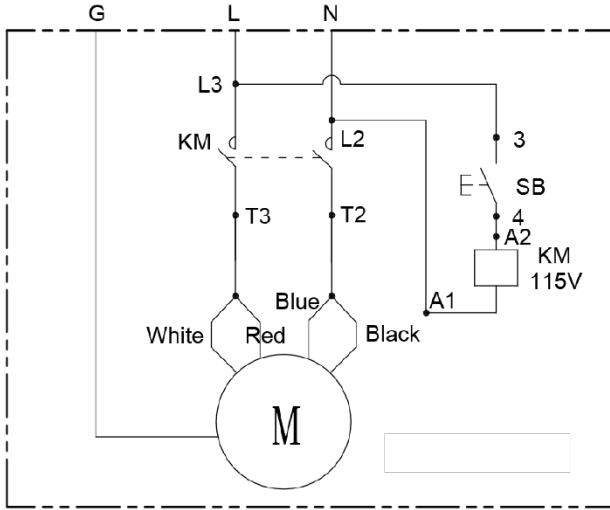

Wired 115 VAC
1 PH, 1.5 HP, 50-60 Hz

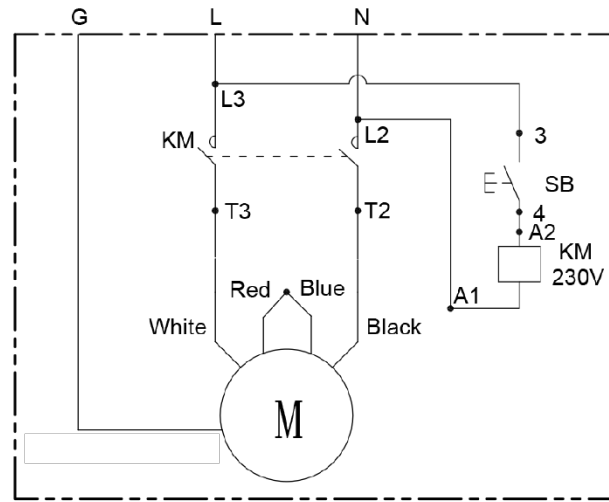

Wired 230 VAC
1 PH, 1.5 HP, 50-60 Hz

5585280

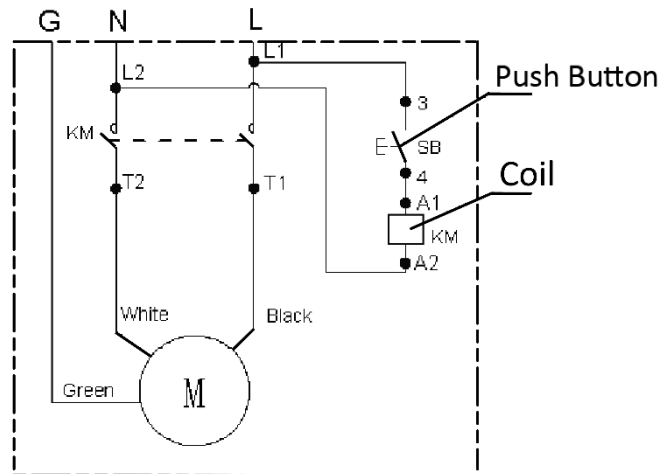

Wired 208-230 VAC
1 PH, 3 HP, 50-60 Hz

5585079

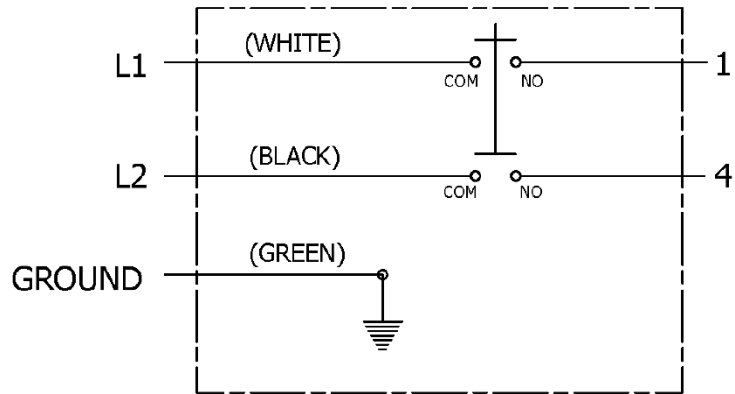

Wired 208-230 VAC
1 PH, 2 HP, 50-60 Hz

5585780

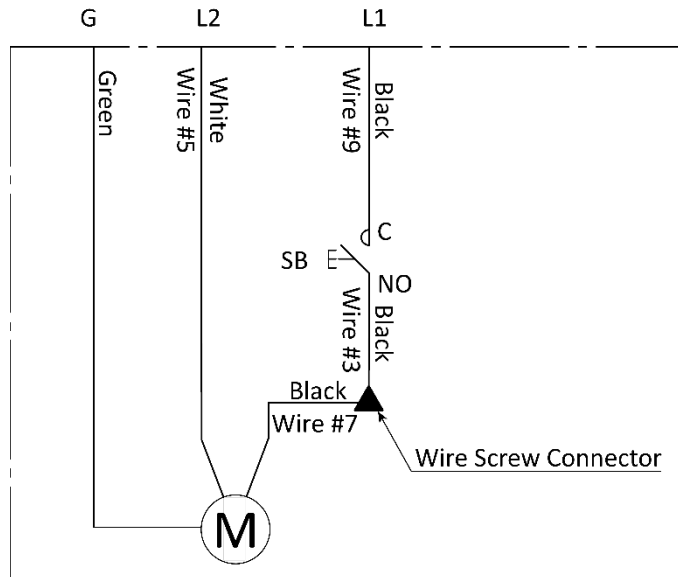

Wired 208-230 VAC
1 PH, 2 HP, 50-60 Hz

Labels

A



B

⚠ DANGER

SAFETY LOCKS ENGAGED — DO TO PROCEED **SAFETY LOCK NOT ENGAGED — REMAIN CLEAR**

SAFETY LADDER **SAFETY LADDER**

SLACK SAFETY **SLACK SAFETY**

PRIMARY SAFETY **PRIMARY SAFETY**

VISUALLY CONFIRM THAT ALL PRIMARY SAFETY LOCKS ARE ENGAGED BEFORE ENTERING WORK AREA.

Suspension components on this lift are intended to raise and lower lift, they are NOT load-holding devices. Do not go under an elevated lift until visual confirmation is made that the lift is engaged on its Safety Locks. Refer to the manual for proper Safety Lock procedures and additional instructions.

⚠ WARNING

Wire Rope Inspection and Maintenance

- Replace lifting cables if wear or damage is evident, such as excessive broken strands, kinks, deformities, or areas of heavy abrasion.
- Keep wire rope in a well-lubricated condition at all times. Wire rope is only fully protected when each wire strand is lubricated, both internally and externally. Excessive wear shortens the life of wire rope. Use wire rope lubricant that penetrates to the core of the rope and provides long-term lubrication between individual strands. Lubrication should be done at least every three months during normal operation.
- All sheaves and guide rollers in contact with the moving wire rope should be given regular visual checks for surface wear and lubricated to make sure they run freely. This should be done at least every three months during normal operation. For sheave axles, use standard wheel bearing grease. For all sheaves and/or guide rollers, use 90-WF gear oil or a similar heavy lubricant applied by any method including pumps/spray dispensers, brush, hand, and/or swabbing.

Failure to read, understand, and follow these instructions may cause death or serious injury. Read and understand these instructions before using lift.

IMPORTANT OPERATION / MAINTENANCE INSTRUCTIONS - PLEASE READ

TO RAISE LIFT

- Position vehicle tires at the center of each Platform.
- Set parking brake or use wheel chocks to lock vehicle in position.
- Before raising vehicle, be sure all personnel are clear of lift and surrounding area. Pay careful attention to overhead obstructions.
- Raise lift to desired height by pressing pedal/button on power unit.
- Maintain visual contact with vehicle and surrounding area at all times while raising lift.
- Stop immediately if load shifts or becomes unlevel.
- After vehicle is raised to desired height, lower lift onto the nearest Safety Lock. Do not allow cables to become excessively slack.
- Always make sure all Primary Safety Locks are engaged before entering work area.

TO LOWER LIFT

- Make sure all personnel, tools, and equipment are clear of lift and surrounding area.
- Lower lift by pressing pedal/button on power unit. Do not lift at least two inches to allow adequate clearance for hooks to clear.
- Press and hold Platform Air Valve.
- Lower vehicle by using pressure and holding. Lowering handles when lowering lift, make sure that all personnel and objects are high clear.
- Always keep a visual line of sight on lift while lowering.
- Always make sure safety locks are disengaged. If one of the locks inadvertently engage, or do not, lift and/or vehicle may slip at causing personal injury or death.

REQUIRED MONTHLY MAINTENANCE

- Consult operation manual for factory recommended maintenance.
- Adjust lift cables to ensure lift raises level and Safety Locks engage simultaneously.
- Check all chain/bolt connections, bolts and pins to ensure proper securing.
- Visually inspect Safety Locks for proper operation.
- Visually inspect concrete. Do not use lift if concrete shows signs of breakage or other deterioration.
- Inspect all anchor bolts, tighten as necessary.
- Check pins for looseness and pin ends.
- Inspect all bolts and other fasteners to make sure they are properly torqued.
- Make a visual inspection of all moving parts and check for signs of excess wear.
- Replace all lift parts before lift is put back into operation.

⚠ WARNING

- Warning: If anchor bolts are loose, or any component of the lift is cracked, do not use lift. Lift is not safe under these conditions. Never operate the lift with potholes or equipment under it.
- Never exceed rated capacity.
- Always ensure Safety Locks are engaged before you attempt to make lift work on or near vehicle.
- Do not use lift if electrical system engaged on Safety Locks.
- Do not permit the electric motor to get wet. Motor damage caused by dampness is not covered by the warranty.

C

⚠ CAUTION **⚠ CAUTION**

Lift to be used by trained operator ONLY.

Authorized personnel only in lift area.

The messages and photographs shown are generic in nature and are meant to generally represent hazards common to all automotive lifts regardless of specific style.

Funding for the development and validation of these labels was provided by the Automotive Lift Institute, PO Box 85 Cortland, NY 13845.

Replacement label sets may be obtained from the original lift manufacturer and ALI's member companies. They are protected by copyright. www.ali.org © 2012 by ALI, Inc.

⚠ WARNING **⚠ WARNING**

Clear area if vehicle is in danger of falling.

Remain clear of lift when raising or lowering vehicle.

⚠ WARNING **⚠ WARNING**

Keep clear of pinch points when lift is moving.

Keep feet clear of lift while lowering.

⚠ WARNING **⚠ WARNING**

Do not override self-closing lift controls.

Check wheel to prevent vehicle movement.

The messages and photographs shown are generic in nature and are meant to generally represent hazards common to all automotive lifts regardless of specific style.

Funding for the development and validation of these labels was provided by the Automotive Lift Institute, PO Box 85 Cortland, NY 13845.

Replacement label sets may be obtained from the original lift manufacturer and ALI's member companies. They are protected by copyright. www.ali.org © 2012 by ALI, Inc.

NOTICE **NOTICE**

Read operating and safety manuals before using lift.

Proper maintenance and inspection is necessary for safe operation.

NOTICE

Do not operate a damaged lift.

The messages and photographs shown are generic in nature and are meant to generally represent hazards common to all automotive lifts regardless of specific style.

Funding for the development and validation of these labels was provided by the Automotive Lift Institute, PO Box 85 Cortland, NY 13845.

Replacement label sets may be obtained from the original lift manufacturer and ALI's member companies. They are protected by copyright. www.ali.org © 2012 by ALI, Inc.

D

▲ DANGER

THE MAXIMUM LIFTING CAPACITY FOR THIS LIFT IS DESCRIBED BELOW

Maximum Lifting Capacity 7,500 lbs. / 3,402 kg
Max. Lifting Cap. / Front of Lift Center 3,750 lbs. / 1,701 kg
Max. Lifting Cap. / Rear of Lift Center 3,750 lbs. / 1,701 kg

Exceeding the weight capacity of this lift can damage lift and/or property and may cause personal harm, injury or death to operators and/or bystanders. All vehicles **MUST** be positioned on lift with **CENTER OF GRAVITY** midway between adapters and/or centered on runways. Damage to lift due to overloading or misuse IS NOT covered under warranty.

LA CAPACITÉ DE LEVAGE MAXIMUM POUR CE LEVAGE EST DÉCRIT CI-DESSOUS

Capacité de Levage Maximale 7,500 lbs. / 3,402 kg
Max. Capuchon De Levage. / Avant du centre de relèvement 3,750 lbs. / 1,701 kg
Max. Capuchon De Levage. / Arrière du centre de levage 3,750 lbs. / 1,701 kg

Le dépassement de la capacité de poids de cet élévateur peut endommager l'ascenseur et / ou les biens et peut causer des dommages corporels, des blessures voire la mort aux opérateurs et / ou aux passants. Tous les véhicules **DOIVENT** être placés sur l'élévateur avec la **CENTRE DE GRAVITÉ** à mi-chemin entre les adaptateurs et / ou au centre des pistes. Dommages à soulever dus à la surcharge ou une mauvaise utilisation **N'EST PAS** couverte par la garantie.

PN 590553

G

NOTICE

If attachments, accessories, or configuration modifying components used on this lift are located in the load path and affect operation of the lift, affect the lift electrical listing, or affect intended vehicle accommodation; and if they are not certified for use on this lift, then the certification of this lift shall become null and void. Contact the participant for information pertaining to certified attachments, accessories, or configuration modifying components.

www.autolift.org ©2011 by ALI, Inc. ALI / WLSIA01

H

▲ WARNING

SLIPPERY WHEN WET OR ICY

Use caution when driving onto wet or icy drive-up ramps and platforms. **DO NOT** walk on lift surfaces that are wet or icy.

▲ AVERTISSEMENT

GLISSANT LORSQU'IL EST MOUILLÉ OU GLACÉ

Soyez prudent lorsque vous conduisez sur des rampes d'accès mouillées ou verglacées et les plateformes. **NE PAS** marcher sur des surfaces de levage humides ou glacées.

PN 590514

I is not used.
J is not used.

E

▲ ATTENTION ▲

**MAXIMUM LIFTING CAPACITY
CAPACITÉ DE LEVAGE MAXIMUM**

**7500 Lbs.
3402 Kg.**

PN 0905700

F

BP BendPak PROVIDING AUTOMOTIVE SERVICE SOLUTIONS SANTA PAULA, CA USA
WWW.BENDPAK.COM PH: 90959140

LIFT TYPE: SURFACE MOUNT MFG. BPK SEE DATA PLATE FOR PRODUCT DETAILS
POWER: ELECTRIC/HYDRAULIC INSTALLATION - SEE OWNERS GUIDE OR CONTACT FACTORY

SAFETY INSTRUCTIONS: IF ATTACHMENTS, ACCESSORIES OR CONFIGURATION MODIFYING COMPONENTS THAT ARE LOCATED IN THE LOAD PATH, AFFECT OPERATION OF THE LIFT, AFFECT THE LIFT ELECTRICAL LISTING OR AFFECT INTENDED VEHICLE ACCOMMODATION ARE USED ON THIS LIFT AND, IF THEY ARE NOT CERTIFIED FOR USE ON THIS LIFT, THEN THE CERTIFICATION OF THIS LIFT SHALL BECOME NULL AND VOID. CONTACT THE PARTICIPANT FOR INFORMATION PERTAINING TO CERTIFIED ATTACHMENTS, ACCESSORIES OR CONFIGURATION MODIFYING COMPONENTS.

BENDPAK LIFTS ARE SUPPLIED WITH CONCRETE FASTENERS MEETING THE CRITERIA AS PRESCRIBED BY ASTM E488 - 06(2003). LIFT BUYERS ARE RESPONSIBLE FOR ANY SPECIAL REGIONAL, STRUCTURAL AND/OR SEISMIC ANCHORING REQUIREMENTS SPECIFIED BY ANY OTHER AGENCIES AND/OR CODES SUCH AS THE UNIFORM BUILDING CODE (UBC) AND/OR INTERNATIONAL BUILDING CODE (IBC).

THE MANUFACTURE, USE, SALE OR IMPORT OF THIS PRODUCT MAY BE SUBJECT TO ONE OR MORE UNITED STATES PATENTS, OR PENDING APPLICATIONS, OWNED BY BENDPAK, INC.
DO NOT REMOVE ENGINEERED BY BENDPAK INC. USA MADE IN CHINA

K

BP BendPak Santa Paula, CA USA
www.bendpak.com

MODEL NUMBER	
DESCRIPTION	
LIFT CAPACITY	DATE OF MFG.
ROLLING JACK MAX CAP.	MAX PSI / BAR
VOLTAGE	SERIAL NUMBER
<input type="checkbox"/> 110-240V, 50-60 Hz, 1 Ph <input type="checkbox"/> 208-240V, 50-60 Hz, 1 Ph <input type="checkbox"/> 380-415V, 50-60 Hz, 3 Ph <input type="checkbox"/> 208-440V, 50-60 Hz, 3 Ph	UPC

▲ DANGER! Disconnect Power Before Servicing
WARRANTY VOID IF DATA PLATE IS REMOVED PN 5905652

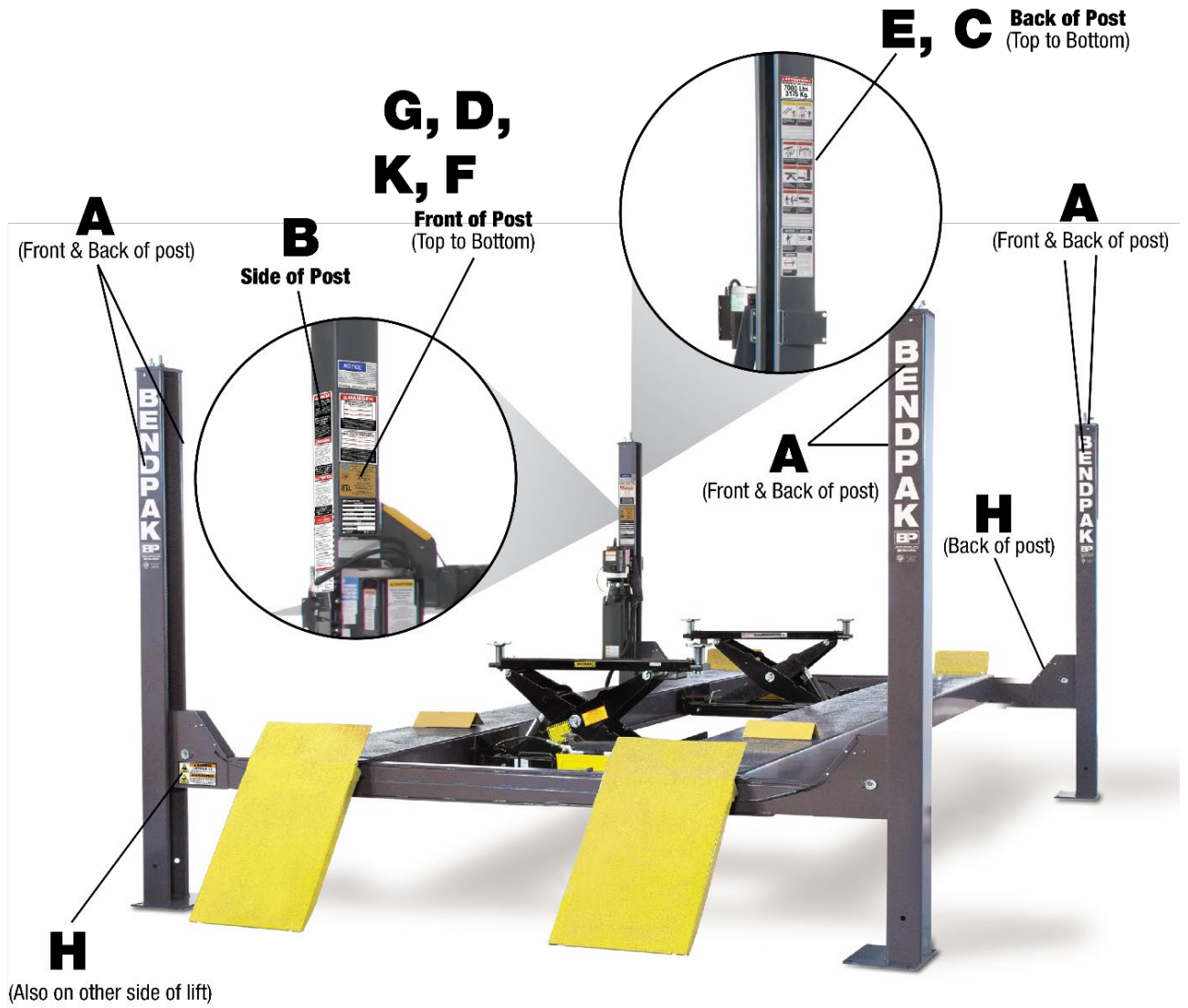

Parts Drawings

Model: HD-7500BLX

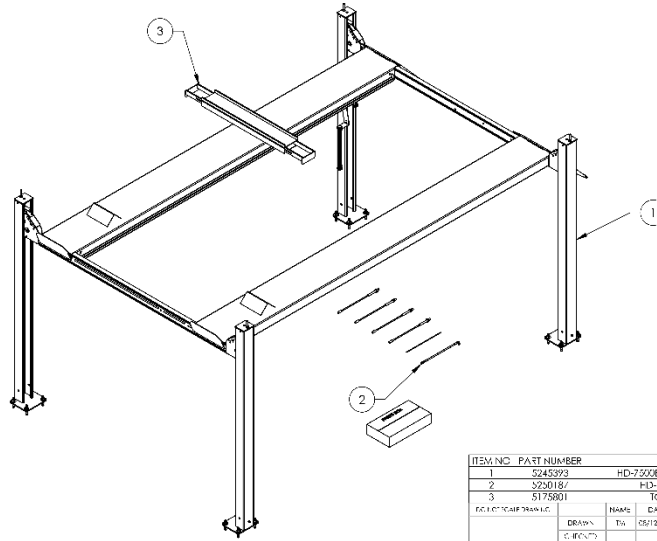

NOTE: UNLESS OTHERWISE SPECIFIED:
 1. REFER TO MODEL FOR ADDITIONAL INFORMATION
 2. SEE SHIPPING INSTRUCTIONS FOR FINAL PACKAGING
 3. SEE COLORS & GRAPHICS FOR LABEL PLACEMENT

ITEM NO.	PART NUMBER	DESCRIPTION	QTY	REV
1	5245993	HD-7500BLX LIFT SUPERSTRUCTURE	1	Y
2	5240187	HD-7500BLX PAK S BOX	1	L
3	5175801	TC-3000 ASSEMBLY	1	D

ECN: 10170487 DATE: 11/11/2024 BY: [Signature]	NAME: [Signature] DATE: 11/11/2024 BY: [Signature]	BP BendPak 1540 BOND STREET DR SANTA ANA, CA 92708
TITLE: HD-7500BLX PRODUCTION LIFT VER D (CE CERT)		SIZE: 11x17 DWG NO: 5260531 REV: AG
SCALE: 1:35		SHEET: 1 OF 3

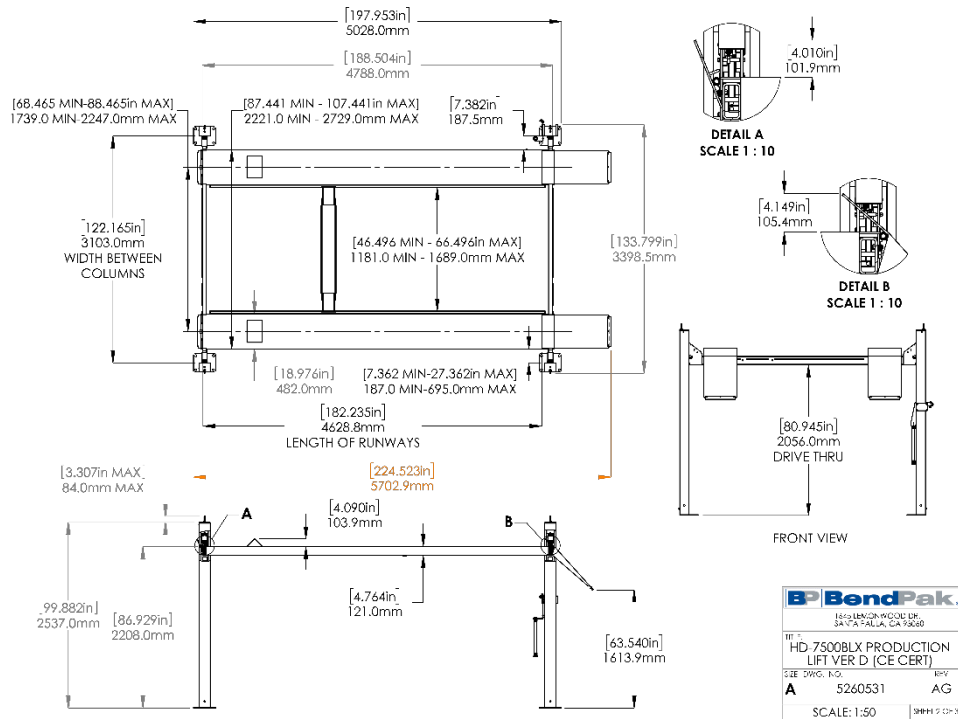

BP BendPak 1540 BOND STREET DR SANTA ANA, CA 92708	
TITLE: HD-7500BLX PRODUCTION LIFT VER D (CE CERT)	
SIZE: 11x17 DWG NO: 5260531 REV: AG	SCALE: 1:50 SHEET: 2 OF 3

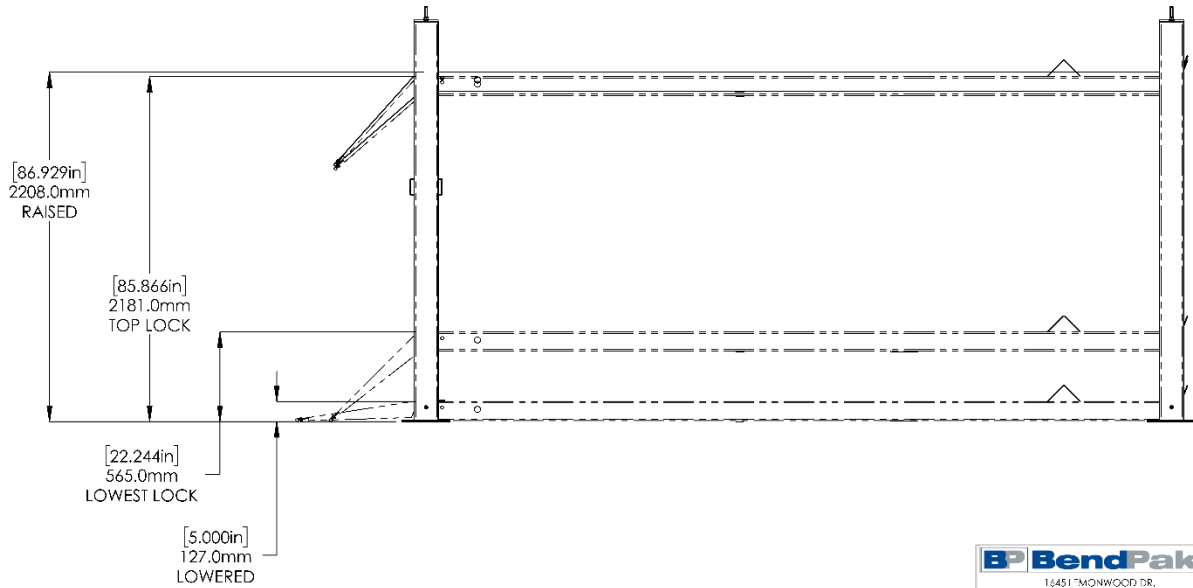

1. DIMENSIONS SHOWN ARE WITH THE LOCK LADDERS ADJUSTED ALL THE WAY UP
2. SAFETY LOCK POSITIONS: 17
3. SPACED EVERY: 101.0mm / 3.976"

BP BendPak.
16451 MONWOOD DR.
SANTA ANITA, CA 95060

TITLE: HD-7500BLX PRODUCTION LIFT VER D (CE CERT)

SIZE	DWG. NO.	REV
A	5260531	AG

SCALE: 1:30 SHEET 3 OF 3

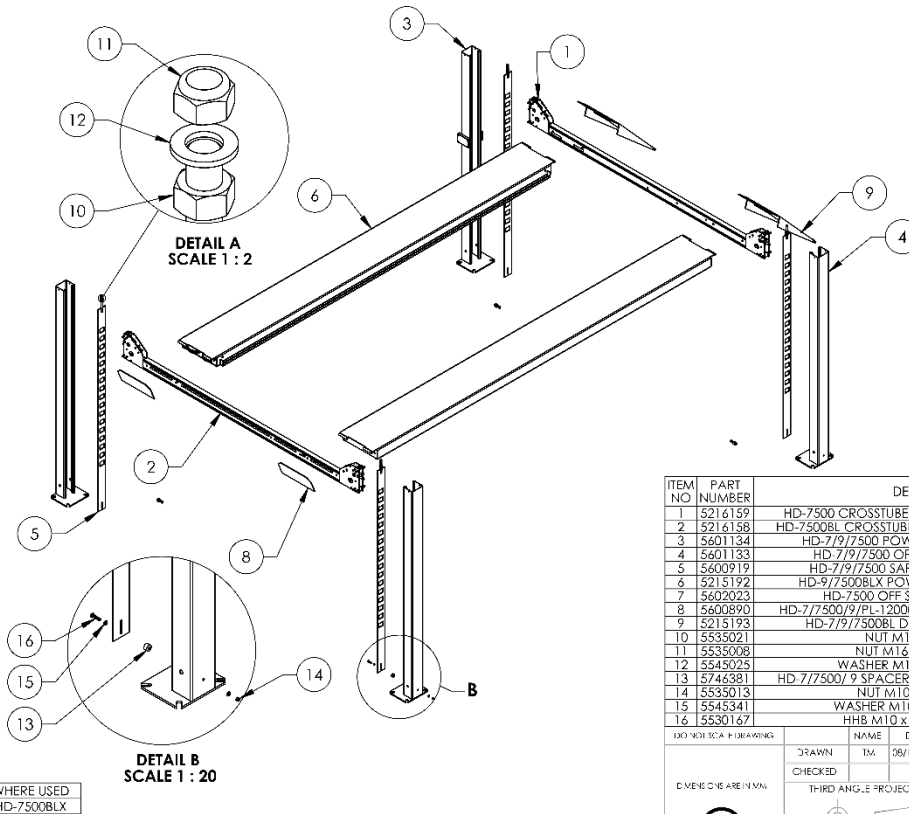

- NOTE: UNLESS OTHERWISE SPECIFIED
1. SEE SHIPPING INSTRUCTIONS FOR FINAL PACKAGING
 2. THREAD M16 HARDWARE ONTO LADDER BOLTS AS SHOWN

ITEM NO	PART NUMBER	DESCRIPTION	QTY	REV
1	5216159	HD-7500 CROSSTUBE ASSEMBLY, SMALL WINDOW	1	A
2	5216158	HD-7500BL CROSSTUBE ASSEMBLY, LARGE WINDOW	1	A
3	5601134	HD-7/9/7500 POWER SIDE POST WELDMENT	1	C
4	5601133	HD-7/9/7500 OFF SIDE POST WELDMENT	3	C
5	5600919	HD-7/9/7500 SAFETY LADDER WELDMENT	4	C
6	5215192	HD-9/7500BLX POWER SIDE RAMP ASSEMBLY	1	AD
7	5602023	HD-7500 OFF SIDE RAMP WELDMENT	1	A
8	5600890	HD-7/7500/9/PL-12000 TIRE STOP PLATE WELDMENT	2	F
9	5215193	HD-7/9/7500BL DRIVE UP RAMP ASSEMBLY	2	G
10	5535021	NUT M16 x 2.0, CL 10.9	4	-
11	5535008	NUT M16 x 2.0 NL, CL 10.9	4	-
12	5543025	WASHER M16 x 30 FLAT, CL 10.9	4	-
13	5746381	HD-7/7500/9 SPACER, SAFETY LADDER, 17.5mm LG	4	B
14	5535013	NUT M10 x 1.5 NL, CL 10.9	4	-
15	5545341	WASHER M10 x Ø20 FLAT, CL 10.9	8	-
16	5530167	HBB M10 x 1.5 x 45 FT, CL 10.9	4	-

100% SOLID SCA. P. DRAWINGS

DRAWN	NAME	DATE
TM		08/11/20 4

CHECKED:

DIMENSIONS ARE IN MM

THIRD ANGLE PROJECTION

PROPRIETARY AND CONFIDENTIAL
NO REPAIR, REUSE, OR REPRODUCTION OF THIS DRAWING IS PERMITTED WITHOUT THE WRITTEN PERMISSION OF BENDPAK INC. ALL RIGHTS RESERVED. © 2024 BENDPAK INC.

BP BendPak.
16451 MONWOOD DR.
SANTA ANITA, CA 95060

TITLE: HD-7500BLX LIFT SUPERSTRUCTURE

SIZE	DWG. NO.	REV
A	5245393	Y

SCALE: 1:45 SHEET 1 OF 1

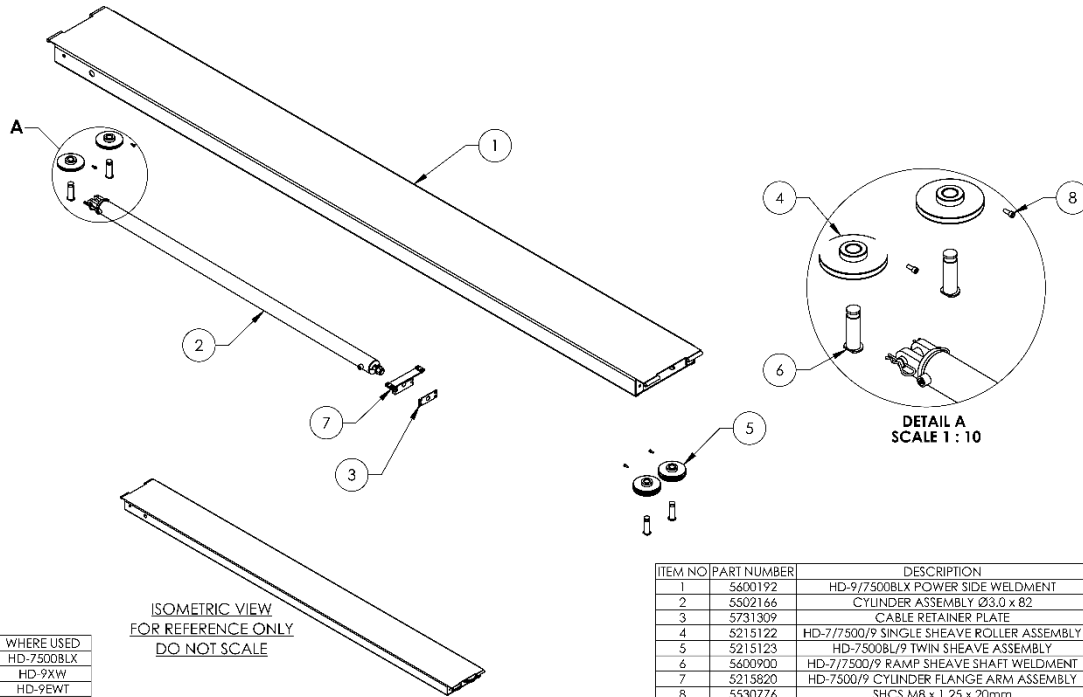

WHERE USED
HD-7500BLX
HD-9XW
HD-9WT
HD-9STX
HD-9SWX
HD-9SWX-E
PL-12000DP

ISOMETRIC VIEW
FOR REFERENCE ONLY
DO NOT SCALE

ITEM NO	PART NUMBER	DESCRIPTION	QTY	REV
1	5600192	HD-9/7500BLX POWER SIDE WELDMENT	1	K
2	5502166	CYLINDER ASSEMBLY Ø3.0 x 82	1	P
3	5731309	CABLE RETAINER PLATE	1	A
4	5215122	HD-7/7500/9 SINGLE SHEAVE ROLLER ASSEMBLY	2	E
5	5215123	HD-7500BL/9 TWIN SHEAVE ASSEMBLY	2	E
6	5600900	HD-7/7500/9 RAMP SHEAVE SHAFT WELDMENT	4	E
7	5215820	HD-7500/9 CYLINDER FLANGE ARM ASSEMBLY	1	B
8	5530776	SHCS M8 x 1.25 x 20mm	4	-

DO NOT SCALE DRAWING

DRAWN	AC	10/ 3/2008	
CHECKED	OR	12/21/2002	
NAME		DATE	1645 LEMONWOOD DR. SANTA PAULA, CA 93060
THIRD ANGLE PROJECTION		TITLE:	HD-9/7500BLX POWER SIDE RAMP ASSEMBLY
SIZE (DWG. NO.)		REV	A 5215192 AD
SCALE: 1:25			SHEET 1 OF 2

NEXT ASSEMBLY	DATE	BY
5245079		
5245254		
5245286		
5245381		
5245392		
5245393		

NOTE: UNLESS OTHERWISE SPECIFIED
 1. REFER TO MODEL FOR ADDITIONAL INFORMATION
 2. SEE SHIPPING INSTRUCTIONS FOR FINAL PACKAGING
 3. ASSEMBLE ITEMS AS SHOWN

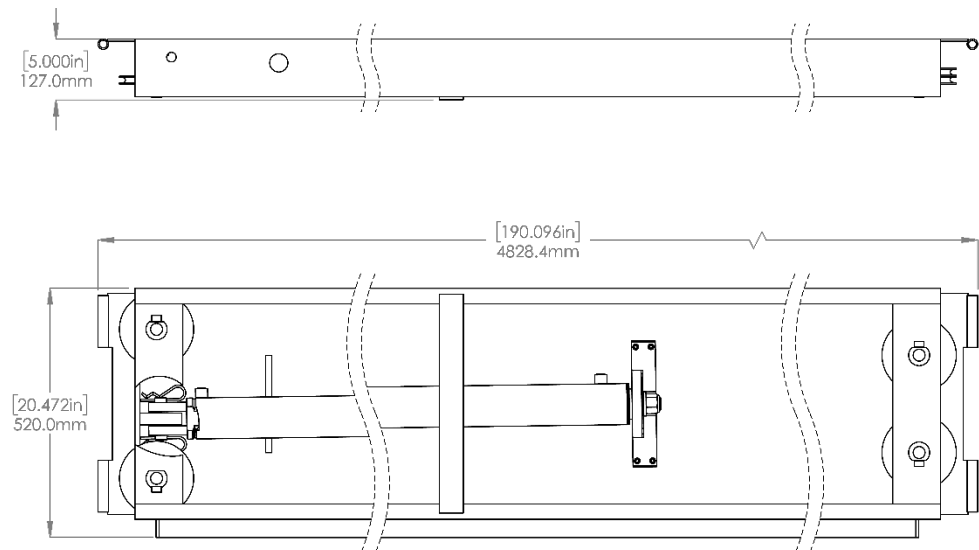

1645 LEMONWOOD DR. SANTA PAULA, CA 93060	
TITLE: HD-9/7500BLX POWER SIDE RAMP ASSEMBLY	
SIZE (DWG. NO.)	REV
A 5215192	AD
SCALE: 1:10	
SHEET 2 OF 2	

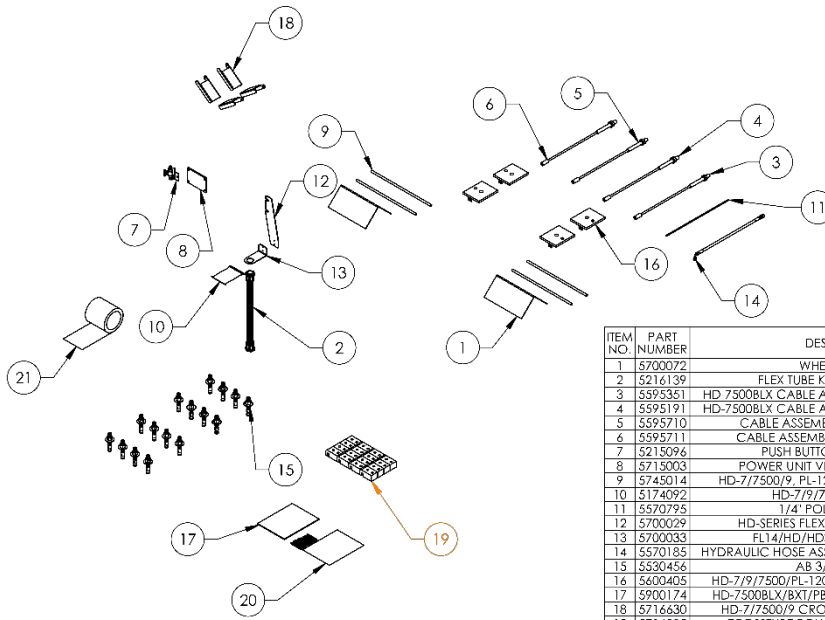

WHERE USED
HD-75BXT

NOTE: UNLESS OTHERWISE SPECIFIED

- SEE SHIPPING INSTRUCTIONS FOR FINAL PACKAGING
- HOSES AND CABLES IN REPRESENTATIONAL FORM
- (*) LENGTH FOR REFERENCE ONLY

ITEM NO.	PART NUMBER	DESCRIPTION	QTY.	REV
1	5700072	WHEEL CHOCK	2	B
2	5216139	FLEX TUBE KIT, UP TO 2000mm	1	A
3	5595351	HD-7500BLX CABLE ASSEMBLY Ø10 x 3228mm ST	1	D
4	5595191	HD-7500BLX CABLE ASSEMBLY Ø10 x 5471mm ST	1	E
5	5595710	CABLE ASSEMBLY Ø10 x 8570mm ST	1	A
6	5595711	CABLE ASSEMBLY Ø10 x 10830mm ST	1	A
7	5215096	PUSH BUTTON AIR ASSEMBLY	1	G
8	5715003	POWER UNIT VIBRATION DAMPENER	1	B
9	5745014	HD-77500/9 FL-12000 DRIVE UP RAMP PIN	4	B
10	5174092	HD-779/7500 PARTS BAG	1	G
11	5570795	1/4" POLY-FLO TUBING	17000*	mm
12	5700029	HD-SERIES FLEX TUBE BRACKET PLATE	1	F
13	5700033	FL14/HD/HDS FLEX TUBE ANGLE	1	E
14	5570185	HYDRAULIC HOSE ASSEMBLY Ø6.35 x 4293mm SB	1	C
15	5530456	AB 3/4" x 4 - 3/4"	16	-
16	5600405	HD-779/7500/PL-12000 TOP PLATE WELDMENT	4	C
17	5900174	HD-7500BLX/PBX/PBX INSTALLATION MANUAL	1	-
18	5716630	HD-77500/9 CROSS TUBE COVER, PLASTIC	4	A
19	5716005	CROSSTUBE POLYETHYLENE SLIDE BLOCK	16	M
20	5210241	4 POST LIGHT DUTY CE PARTS BAG	1	A
21	5930195	ANTI-SLIP TAPE, 6" x 24H	1	-

NEXT ASSEMBLY
5260531

ISO NO. SCALE DRAW'NG	NAME DATE	
DRAWN TM 09/07/2021	CHECKED CR 07/26/2021	
DWG. NO. 5260531	TITLE: HD-75BXT PARTS BOX	645 LIMONWOOD DR. SANTA PAULA, CA 95560
	THIRD ANGLE PROJECTION <small>PROPRIETARY AND CONFIDENTIAL THE INFORMATION CONTAINED HEREIN IS THE PROPERTY OF BENDPAK INC. AND IS NOT TO BE REPRODUCED OR TRANSMITTED IN ANY FORM OR BY ANY MEANS, ELECTRONIC OR MECHANICAL, INCLUDING PHOTOCOPYING, RECORDING, OR BY ANY INFORMATION STORAGE AND RETRIEVAL SYSTEM, WITHOUT THE WRITTEN PERMISSION OF BENDPAK INC. © 2020 B.P.</small>	SCALE: 1:25 SHEET 1 OF 1

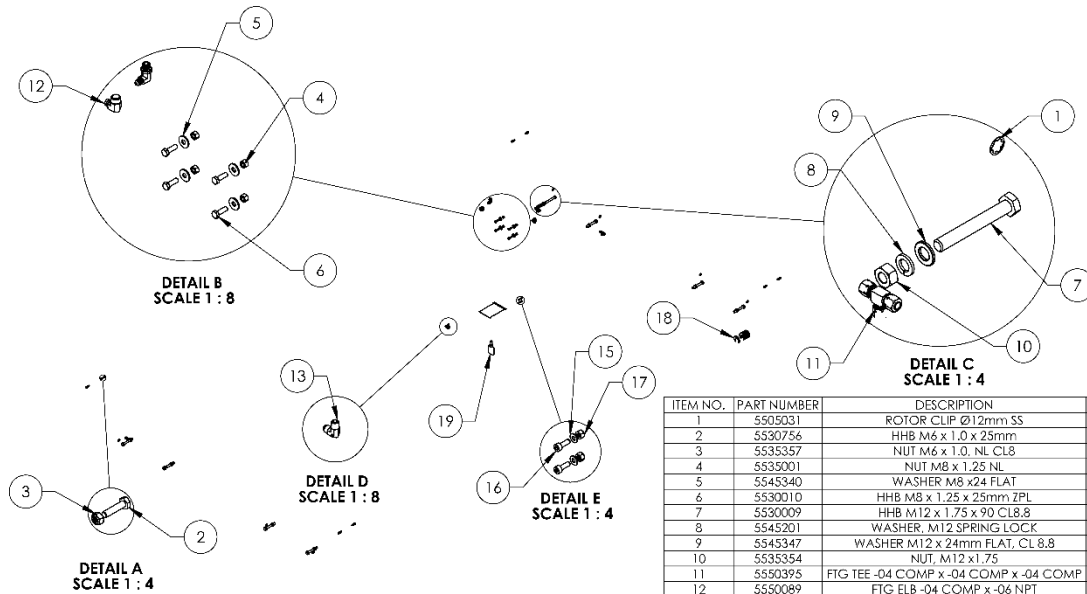

WHERE USED	
HD-7W	HD-9
HD-7P	HD-9XW
HD-75BXT	HD-9EWT
HD-7500BLX	HD-9XL
	HD-9STX

NOTE: UNLESS OTHERWISE SPECIFIED

- REFER TO MODEL FOR ADDITIONAL INFORMATION
- SEE SHIPPING INSTRUCTIONS FOR FINAL PACKAGING

NEXT ASSEMBLY
5250164
5250167
5250168
5250169
5250184
5250187
5250188
5250189
5250338
5250376

ITEM NO.	PART NUMBER	DESCRIPTION	QTY.	REV
1	5505031	ROTOR CLIP Ø12mm SS	8	-
2	5530756	HHB M6 x 1.0 x 25mm	8	-
3	5535357	NUT M6 x 1.0, NL CLB	8	-
4	5535001	NUT M8 x 1.25 NL	4	-
5	5545340	WASHER M6 x24 FLAT	4	-
6	5530010	HHB M8 x 1.25 x 25mm ZPL	4	-
7	5530009	HHB M12 x 1.75 x 90 CL8.8	8	-
8	5545201	WASHER, M12 SPRING LOCK	8	-
9	5545347	WASHER M12 x 24mm FLAT, CL.8.8	8	-
10	5535354	NUT, M12 x 1.75	8	-
11	5550395	FTG TEE -04 COMP x -04 COMP x -04 COMP	3	-
12	5550089	FTG ELB -04 COMP x -06 NPT	2	-
13	5550106	FTG ELB -04JIC x 3/8" NPT	1	-
14	5550008	FTG ELB -04 JIC -06L ORB	1	-
15	5545009	WASHER, M4 x 9mm FLAT	2	-
16	5530008	SHCS M4 x 0.7 x 12 BOC	2	-
17	5550110	NUT M4 x 0.7, NL CLB	2	-
18	5545335	C WASHER SHIM FOR LIFTS	20	-
19	5580012	LIQUID PTFE THREAD SEALANT 50ml	1	-

ISO NO. SCALE DRAW'NG	NAME DATE	
DRAWN AC 08/08/2008	CHECKED CR 07/26/2021	
DWG. NO. 5174092	TITLE: HD-779/7500 PARTS BAG	1345 LIMONWOOD DR. SANTA PAULA, CA 95560
	THIRD ANGLE PROJECTION <small>PROPRIETARY AND CONFIDENTIAL THE INFORMATION CONTAINED HEREIN IS THE PROPERTY OF BENDPAK INC. AND IS NOT TO BE REPRODUCED OR TRANSMITTED IN ANY FORM OR BY ANY MEANS, ELECTRONIC OR MECHANICAL, INCLUDING PHOTOCOPYING, RECORDING, OR BY ANY INFORMATION STORAGE AND RETRIEVAL SYSTEM, WITHOUT THE WRITTEN PERMISSION OF BENDPAK INC. © 2020 B.P.</small>	SCALE: 1:30 SHEET 1 OF 1

Model: HD-75BXT

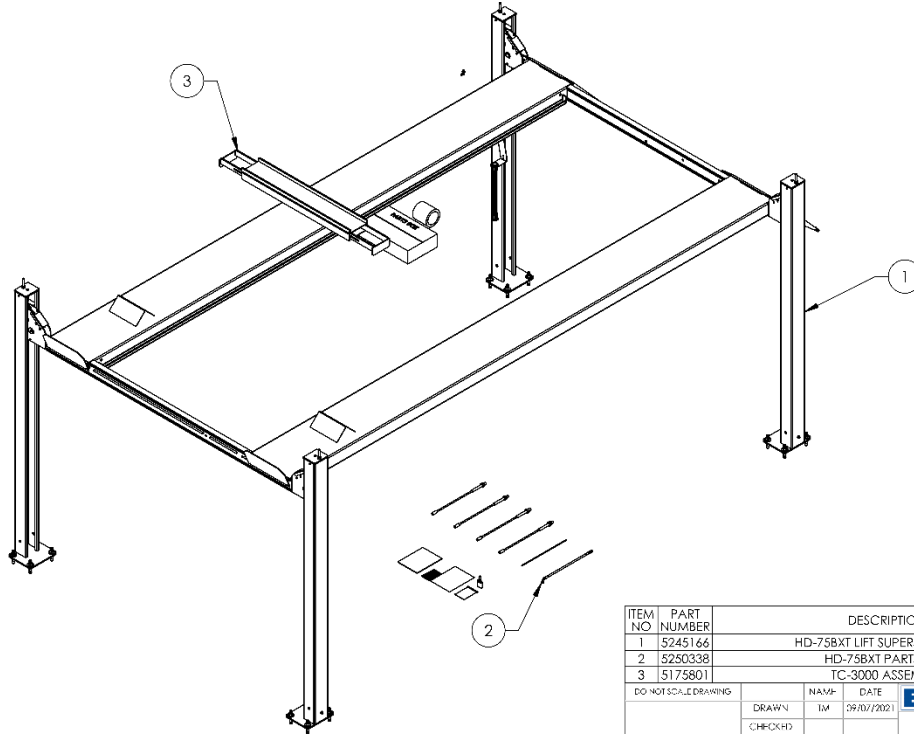

NOTE: UNLESS OTHERWISE SPECIFIED:

1. REFER TO MODEL FOR ADDITIONAL INFORMATION
2. SEE SHIPPING INSTRUCTIONS FOR FINAL PACKAGING
3. SEE COLORS & GRAPHICS FOR LABEL PLACEMENT

ITEM NO	PART NUMBER	DESCRIPTION	QTY	REV
1	5245166	HD-75BXT LIFT SUPERSTRUCTURE	1	E
2	5250338	HD-75BXT PARTS BOX	1	C
3	5175801	TC-3000 ASSEMBLY	1	D

DO NOT SCALE DRAWING		NAME: TM	DATE: 09/07/2021	 16451-MCNW-COPIES DR SANTA PAULA, CA 95060
DRAWN		CHECKED		
DIMENSIONS ARE IN MM		THIRD ANGLE PROJECTION		TITLE: HD-75BXT PRODUCTION LIFT VER A S/P/DWG. NO.: 5260659 REV: F
 <small>PROPRIETARY AND CONFIDENTIAL SEE US AT: 2021 CONEXPO-AGG/CON/AGG-2 BOOTH # 3014 218 BENDPAK INC. #1 800-777-7611 415-227-6100 415-227-6101 8145 TRULIPAS SQ. #2000 BENDPAK INC. #1 FCO - 5000</small>				SCALE: 1:35 SHEET 1 OF 3

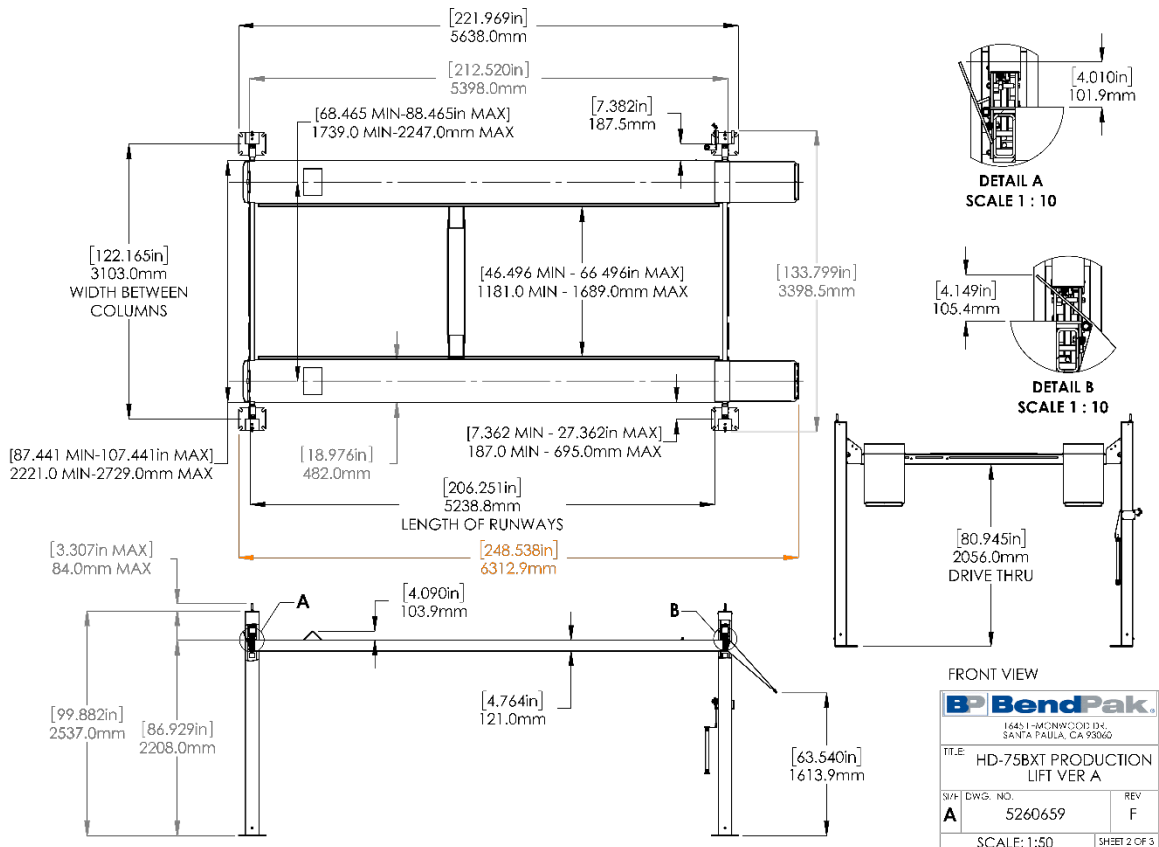

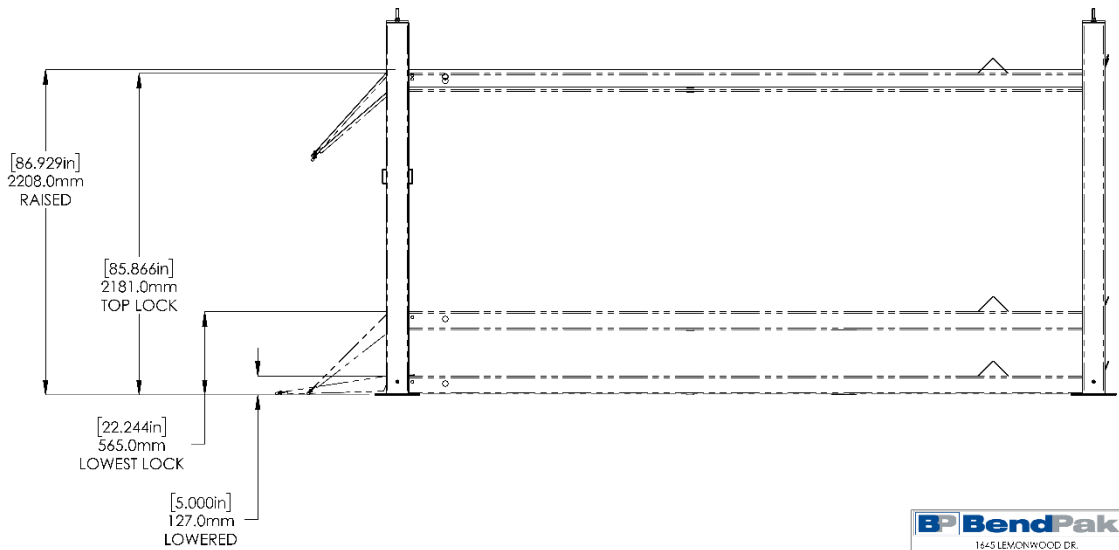

1. DIMENSIONS SHOWN ARE WITH THE LOCK LADDERS ADJUSTED ALL THE WAY UP
2. SAFETY LOCK POSITIONS: 17
3. SPACED EVERY: 101.0mm / 3.976"

BendPak
 1645 LEVONWOOD DR.
 SANTA PAULI, CA 94060

TITLE: HD-7500BLX PRODUCTION LIFT VER D (CE CERT)

SIZE DWG. NO. REV
A 5260531 AG

SCALE: 1:30 SHEET 3 OF 3

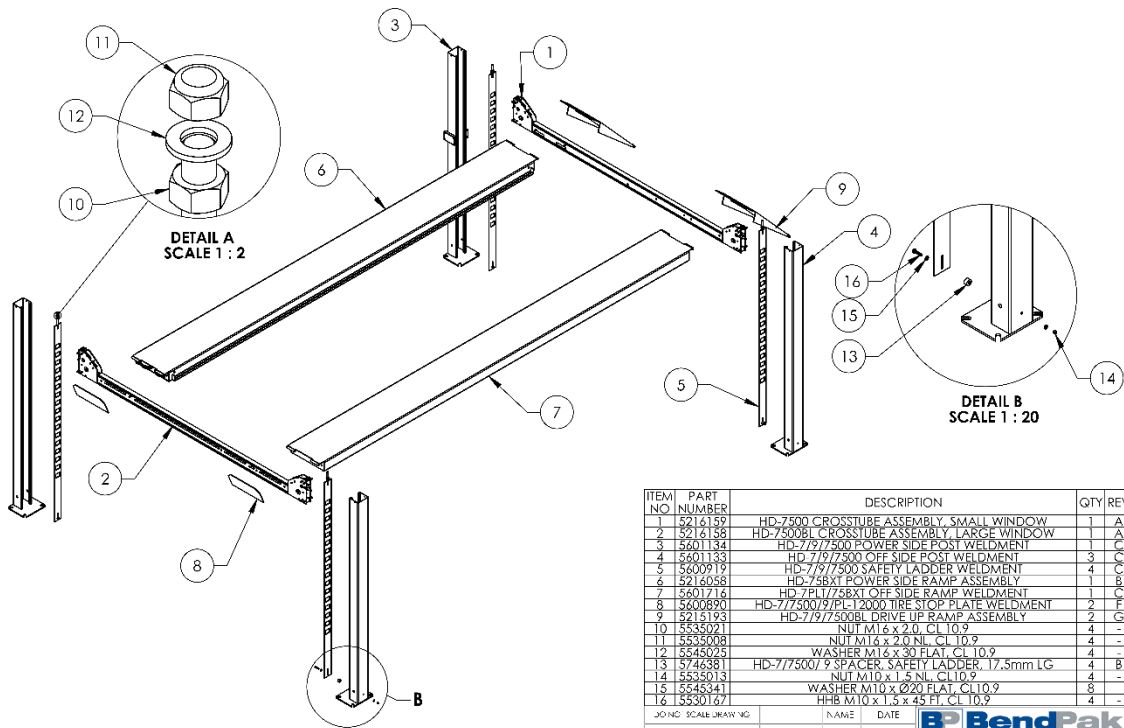

WHERE USED
 HD-75BXT

- NOTE: UNLESS OTHERWISE SPECIFIED**
1. SEE SHIPPING INSTRUCTIONS FOR FINAL PACKAGING
 2. THREAD M16 HARDWARE ONTO LADDER BOLTS AS SHOWN

NEXT ASSEMBLY
 5260659

ITEM NO	PART NUMBER	DESCRIPTION	QTY	REV
1	5214159	HD-7500 CROSSTUBE ASSEMBLY, SMALL WINDOW	1	A
2	5214158	HD-7500BL CROSSTUBE ASSEMBLY, LARGE WINDOW	1	A
3	5601134	HD-7/9/7500 POWER SIDE POST WELDMENT	1	C
4	5601133	HD-7/9/7500 OFF SIDE POST WELDMENT	3	C
5	5600919	HD-7/9/7500 SAFETY LADDER WELDMENT	4	C
6	5216058	HD-75BXT POWER SIDE RAMP ASSEMBLY	1	B
7	5601216	HD-7/PL/75BXT OFF SIDE RAMP WELDMENT	1	C
8	5600890	HD-7/7500/9/PL-12000 TIRE STOP PLATE WELDMENT	2	F
9	5215193	HD-7/9/7500BL DRIVE UP RAMP ASSEMBLY	2	G
10	5535021	NUT M16 x 2.0, CL 10.9	4	-
11	5535008	NUT M16 x 2.0 NL, CL 10.9	4	-
12	5545035	WASHER M16 x 30 FLAT, CL 10.9	4	-
13	5746381	HD-7/7500/9 SPACER, SAFETY LADDER, 17.5mm LG	4	B
14	5535013	NUT M10 x 1.5 NL, CL 10.9	4	-
15	5545341	WASHER M10 x Ø20 FLAT, CL 10.9	8	-
16	5530167	HHB M10 x 1.5 x 45 FT, CL 10.9	4	-

JO: NO SCALE: DRAW: NO

DRAWN: TM DATE: 09/07/2021

CHECKED:

DIMENSIONS ARE IN: MM

THIRD ANGLE PROJECTION

BendPak
 1645 LEVONWOOD DR.
 SANTA PAULI, CA 94060

TITLE: HD-75BXT LIFT SUPERSTRUCTURE

SIZE DWG. NO. REV
A 5245166 E

SCALE: 1:45 SHEET 1 OF 1

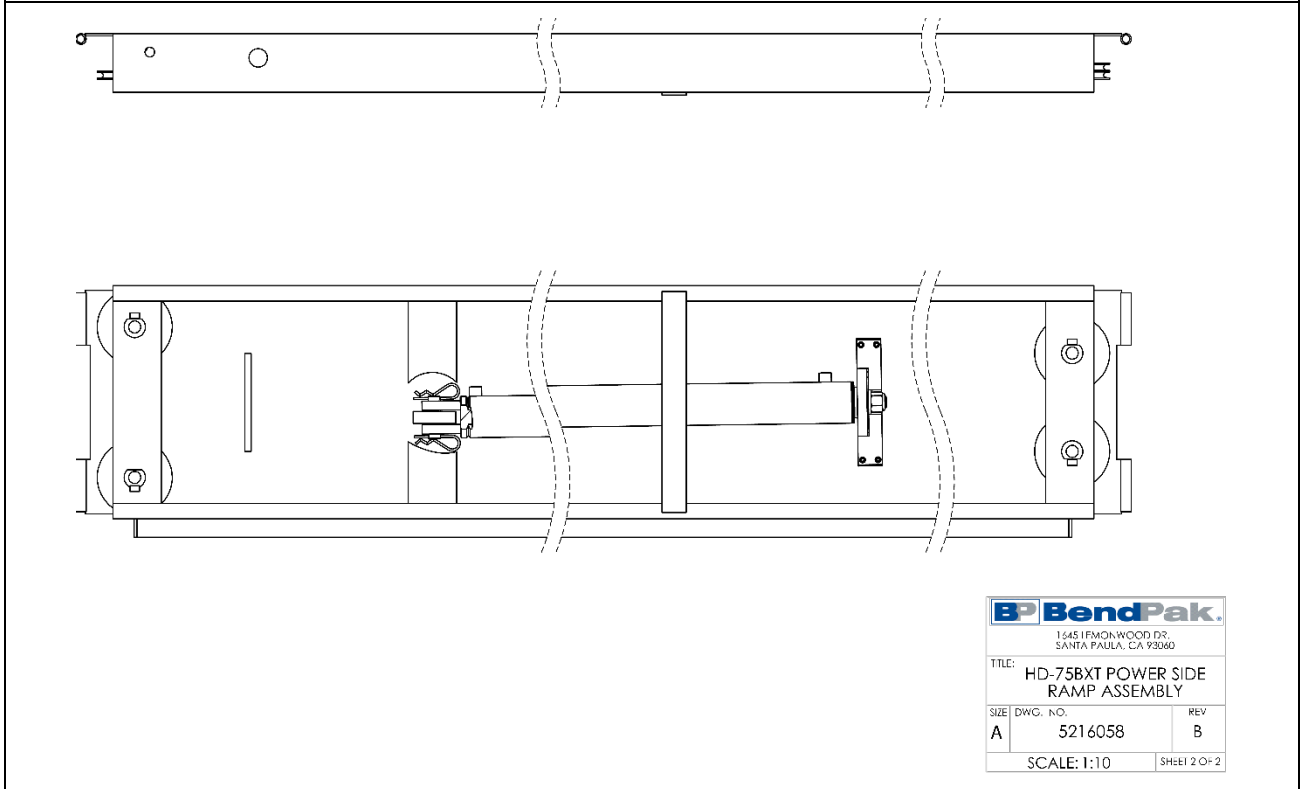
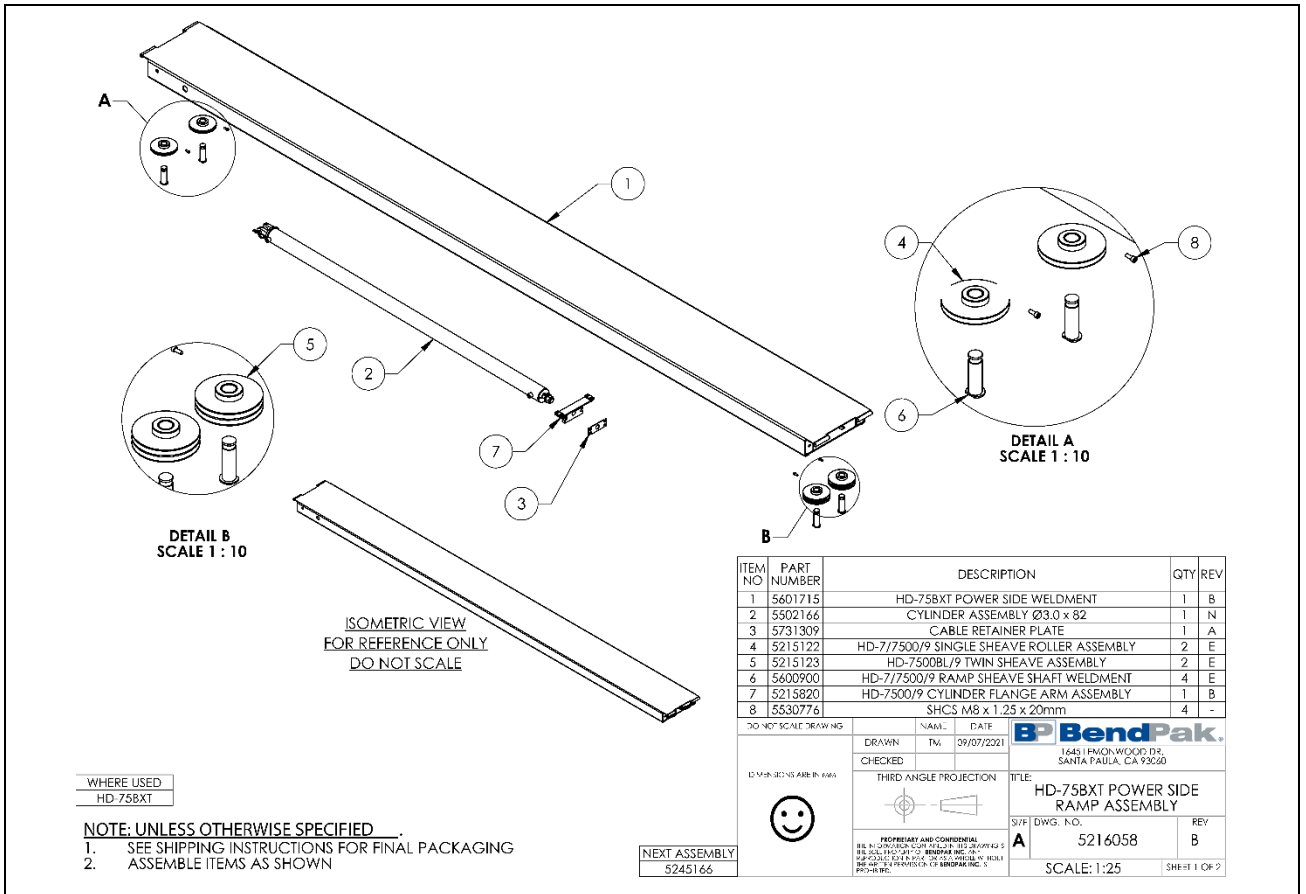

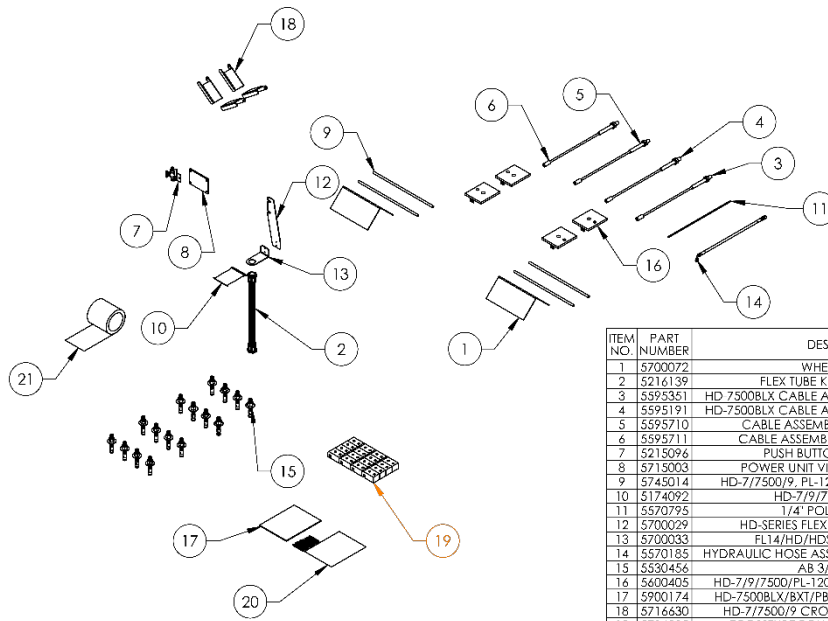

WHERE USED
HD-75BXT

- NOTE: UNLESS OTHERWISE SPECIFIED**
- SEE SHIPPING INSTRUCTIONS FOR FINAL PACKAGING
 - HOSES AND CABLES IN REPRESENTATIONAL FORM
 - (*) LENGTH FOR REFERENCE ONLY

ITEM NO.	PART NUMBER	DESCRIPTION	QTY.	REV
1	5700072	WHEEL CHOCK	2	B
2	5216139	FLEX TUBE KIT UP TO 2000mm	1	A
3	5595351	HD-7500BLX CABLE ASSEMBLY Ø10 x 3228mm ST	1	D
4	5595191	HD-7500BLX CABLE ASSEMBLY Ø10 x 5471mm ST	1	E
5	5595710	CABLE ASSEMBLY Ø10 x 8570mm ST	1	A
6	5595711	CABLE ASSEMBLY Ø10 x 10830mm ST	1	A
7	5215096	PUSH BUTTON AIR ASSEMBLY	1	G
8	5715003	POWER UNIT VIBRATION DAMPENER	1	B
9	5745014	HD-7/7500/9, PL-12000 DRIVE UP RAMP PIN	4	B
10	5174092	HD-7/9/7500 PARTS BAG	1	G
11	5570795	1/4" POLY-FLO TUBING	17000*mm	-
12	5700029	HD-SERIES FLEX TUBE BRACKET PLATE	1	F
13	5700033	FL14/HD/HDS FLEX TUBE ANGLE	1	E
14	5570185	HYDRAULIC HOSE ASSEMBLY Ø6.35 x 4293mm SB	1	C
15	5530456	AB 3/4" x 4 - 3/4"	16	-
16	5600405	HD-7/9/7500/PL-12000 TOP PLATE WELDMENT	4	C
17	5900174	HD-7500BLX/BXT/PBX INSTALLATION MANUAL	1	-
18	5716630	HD-7/7500/9 CROSSTUBE COVER, PLASTIC	4	A
19	5716005	CROSSTUBE POLYETHYLENE SLIDE BLOCK	16	M
20	5210241	4 POST LIGHT DUTY CE PARTS BAG	1	A
21	5930195	ANTI-SLIP TAPE, 6" x 241"	1	-

D03 MD3 SCALE DRAWING
 DRAWN: IM 09/07/2021
 CHECKED: IM 09/07/2021
 THIRD ANGLE PROJECTION
 TITLE: HD-75BXT PARTS BOX
 SIZE: A DWG. NO. 5250338 REV. C
 SCALE: 1:25 SHEET 1 OF 1

BendPak
 645 LEWIS WOOD DR.
 SANTA PAULA, CA 93080

PROPRIETARY AND CONFIDENTIAL
 THE INFORMATION CONTAINED HEREIN IS THE PROPERTY OF BENDPAK INC. AND IS NOT TO BE REPRODUCED OR TRANSMITTED IN ANY FORM OR BY ANY MEANS, ELECTRONIC OR MECHANICAL, INCLUDING PHOTOCOPYING, RECORDING, OR BY ANY INFORMATION STORAGE AND RETRIEVAL SYSTEM.

NEXT ASSEMBLY
5260531

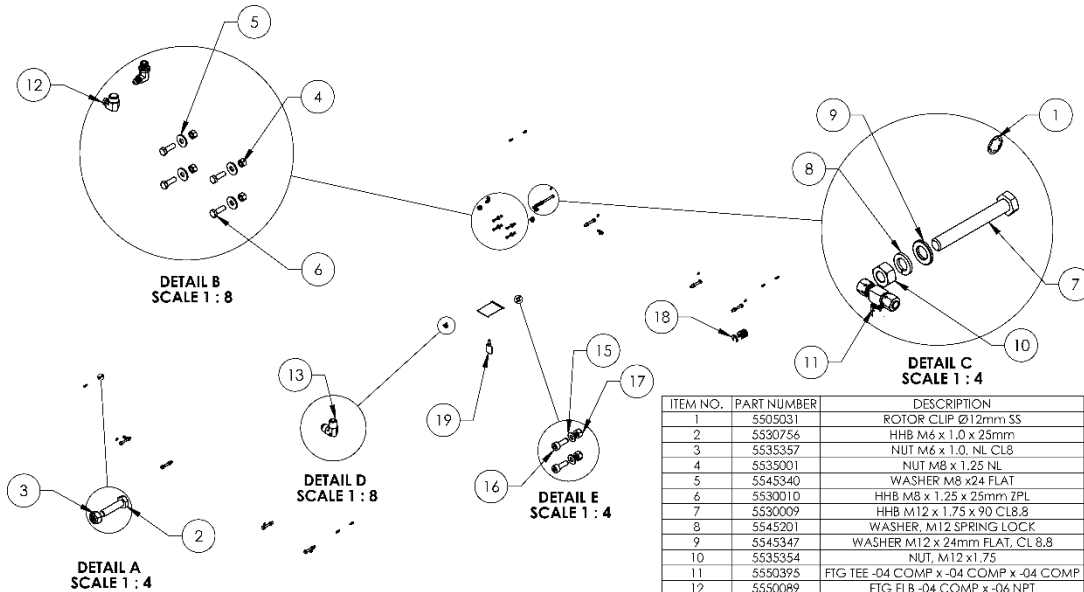

WHERE USED
HD-7W HD-9
HD-7P HD-9XW
HD-75BXT HD-9EWI
HD-7500BLX HD-9XL
HD-9STX

- NOTE: UNLESS OTHERWISE SPECIFIED**
- REFER TO MODEL FOR ADDITIONAL INFORMATION
 - SEE SHIPPING INSTRUCTIONS FOR FINAL PACKAGING

ITEM NO.	PART NUMBER	DESCRIPTION	QTY.	REV
1	5505031	ROTOR CLIP Ø12mm SS	8	-
2	5550756	HBB M6 x 1.0 x 25mm	8	-
3	5553557	NUT M6 x 1.0, NL CL8	8	-
4	5593001	NUT M8 x 1.25 NL	4	-
5	5543340	WASHER M8 x24 FLAT	4	-
6	5593010	HBB M8 x 1.25 x 25mm ZPL	4	-
7	5590009	HBB M12 x 1.75 x 90 CL8.8	8	-
8	5545201	WASHER, M12 SPRING LOCK	8	-
9	5545347	WASHER M12 x 24mm FLAT, CL 8.8	8	-
10	5535354	NUT, M12 x1.75	8	-
11	5590395	FTG TEE -04 COMP x -04 COMP x -04 COMP	3	-
12	5550089	FTG ELB -04 COMP x -06 NPT	2	-
13	5550106	FTG ELB -04JIC x 3/8" NPT	1	-
14	5550008	FTG ELB -04 JIC -06L ORB	1	-
15	5545009	WASHER, M4 x 9mm FLAT	2	-
16	5530008	SHCS M4 x 0.7 x 12 BOC	2	-
17	5535010	NUT M4 x 0.7, NL CL8	2	-
18	5545335	C WASHER SHIM FOR LIFTS	20	-
19	5580012	LIQUID PTFE THREAD SEALANT 50ml	1	-

D03 MD3 SCALE DRAWING
 DRAWN: AC 08/08/2008
 CHECKED: CR 07/26/2021
 THIRD ANGLE PROJECTION
 TITLE: HD-7/9/7500 PARTS BAG
 SIZE: A DWG. NO. 5174092 REV. G
 SCALE: 1:30 SHEET 1 OF 1

BendPak
 1361 LEWIS WOOD DR.
 SANTA PAULA, CA 93080

PROPRIETARY AND CONFIDENTIAL
 THE INFORMATION CONTAINED HEREIN IS THE PROPERTY OF BENDPAK INC. AND IS NOT TO BE REPRODUCED OR TRANSMITTED IN ANY FORM OR BY ANY MEANS, ELECTRONIC OR MECHANICAL, INCLUDING PHOTOCOPYING, RECORDING, OR BY ANY INFORMATION STORAGE AND RETRIEVAL SYSTEM.

NEXT ASSEMBLY
5250144
5250167
5250168
5250169
5250184
5250187
5250188
5250189
5250338
5250376

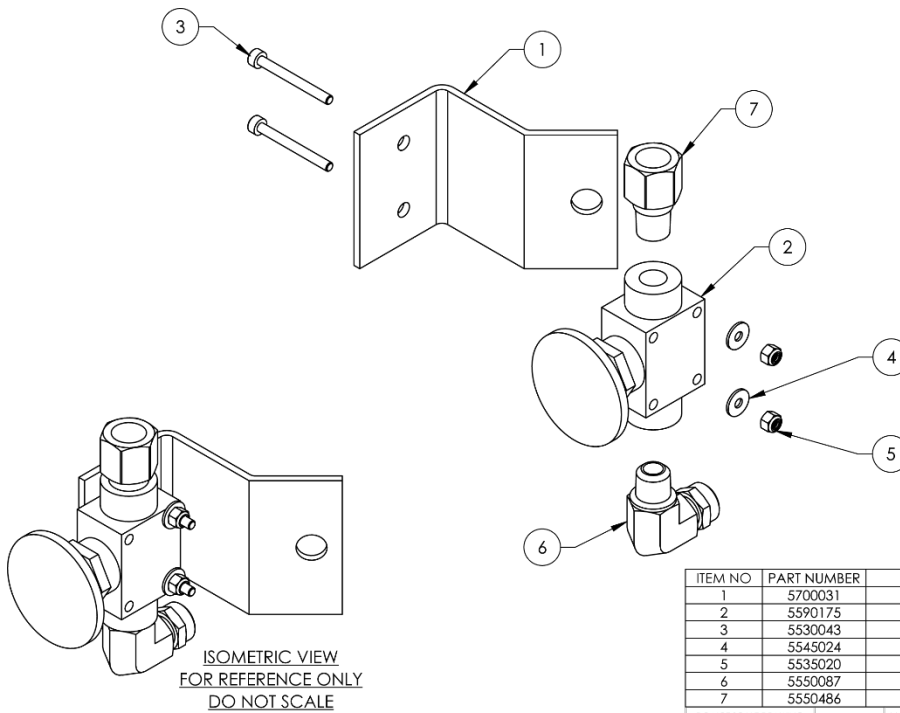

ITEM NO	PART NUMBER	DESCRIPTION	QTY	REV
1	5700031	ZERO ANGLE MOUNTING BRACKET	1	C
2	5590175	PUSH BUTTON AIR VALVE	1	-
3	5530043	SHCS M3 x 0.5 x 30	2	-
4	5545024	WASHER, M3 x 9mm FLAT	2	-
5	5535020	NUT M3 x 0.5, NL CLB	2	-
6	5550087	FTG ELB -04 COMP x -02 NPT	1	-
7	5550486	FTG NPL -02 NPT x -04 F NPT	1	-

DO NOT SCALE DRAWING	NAME	DATE	 1645 LEMONWOOD DR. SANTA PAULA, CA 93060
DRAWN	AC	03/14/2008	
	CHECKED	CA	09/02/2015
DIMENSIONS ARE IN MM			TITLE: PUSH BUTTON AIR ASSEMBLY
THIRD ANGLE PROJECTION			SIZE DWG. NO. 5215096
			REV G
<small>PROPRIETARY AND CONFIDENTIAL THE INFORMATION CONTAINED IN THIS DRAWING IS THE SOLE PROPERTY OF BENDPAK INC. ANY REPRODUCTION IN PART OR AS A WHOLE WITHOUT THE WRITTEN PERMISSION OF BENDPAK INC. IS PROHIBITED.</small>			SCALE: 2:3
			SHEET 1 OF 1

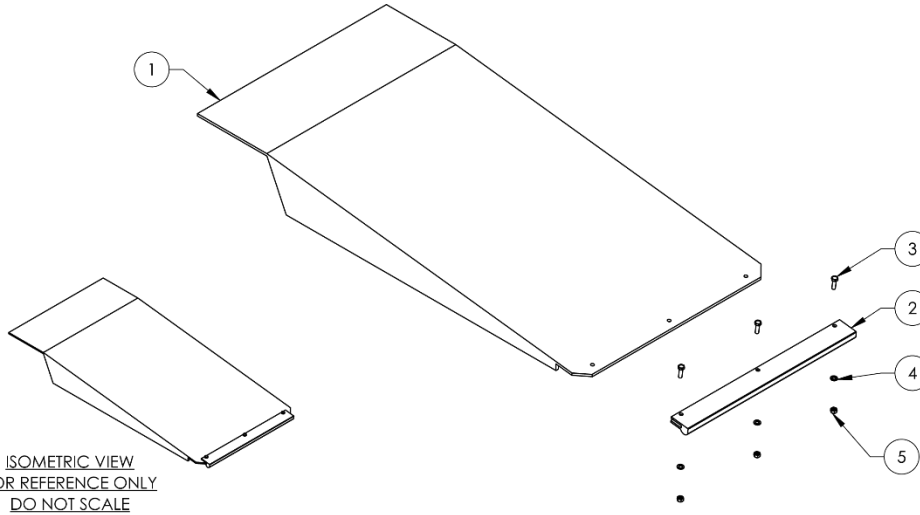

WHERE USED
HD-7 SERIES
HD-9
HD-9ST
HD-9STX
HD-9XL
HD-9XW
HD-973 SERIES
HD-7500 SERIES

ITEM NO	PART NUMBER	DESCRIPTION	QTY	REV
1	5600891	HD-7/9/7500 DRIVE UP RAMP WELDMENT	1	E
2	5716054	APPROACH RAMP EDGE GUARD	1	A
3	5530093	HHB M6 x 1.0 x 20mm	3	A
4	5545005	WASHER, M6 x 12mm FLAT	3	A
5	5535357	NUT M6 x 1.0, NL CLB	3	-

DO NOT SCALE DRAWING	NAME	DATE	 1645 LEMONWOOD DR. SANTA PAULA, CA 93060
DRAWN	AC	11/13/2008	
	CHECKED	CR	04/20/2020
DIMENSIONS ARE IN MM			TITLE: HD-7/9/7500BL DRIVE UP RAMP ASSEMBLY
THIRD ANGLE PROJECTION			SIZE DWG. NO. 5215193
			REV G
<small>PROPRIETARY AND CONFIDENTIAL THE INFORMATION CONTAINED IN THIS DRAWING IS THE SOLE PROPERTY OF BENDPAK INC. ANY REPRODUCTION IN PART OR AS A WHOLE WITHOUT THE WRITTEN PERMISSION OF BENDPAK INC. IS PROHIBITED.</small>			SCALE: 1:8
			SHEET 1 OF 1

Model: HD-7500PBX

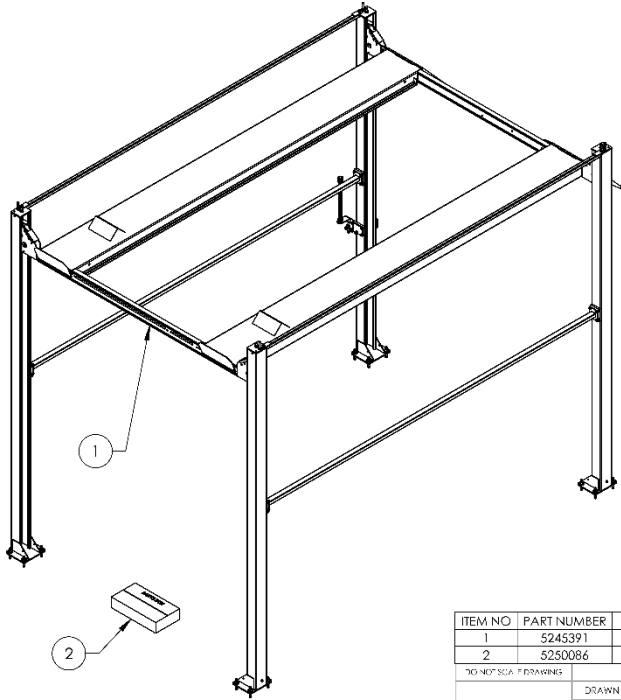

ITEM NO	PART NUMBER	DESCRIPTION	QTY	REV
1	5245391	HD-7500PBX LIFT SUPERSTRUCTURE	1	AD
2	5250086	HD-7500PBX PARTS BOX	1	M

DO NOT SCALE DRAWING	NAME	DATE	 1645 LEIGHWOOD DR. SANTA PALMA, CA 95040
DRAWN	TM	08/12/2014	
CHECKED			HD-7500PBX PRODUCTION LIFT VER C
DIMENSIONS ARE IN INCH	VIEW ANGLE - PROJECTION	UNIT	SIZE DWG. NO. REV A 5260509 AK
 PROPRIETARY AND CONFIDENTIAL THIS DRAWING IS THE PROPERTY OF BENDPAK INC. AND IS NOT TO BE REPRODUCED OR TRANSMITTED IN ANY FORM OR BY ANY MEANS, ELECTRONIC OR MECHANICAL, INCLUDING PHOTOCOPYING, RECORDING, OR BY ANY INFORMATION STORAGE AND RETRIEVAL SYSTEM, WITHOUT THE WRITTEN PERMISSION OF BENDPAK INC. © 2014		SCALE: 1:50	SHEET 1 OF 3

NOTE: UNLESS OTHERWISE SPECIFIED

1. REFER TO MODEL FOR ADDITIONAL INFORMATION
2. SEE SHIPPING INSTRUCTIONS FOR FINAL PACKAGING
3. SEE COLORS & GRAPHICS FOR LABEL PLACEMENT

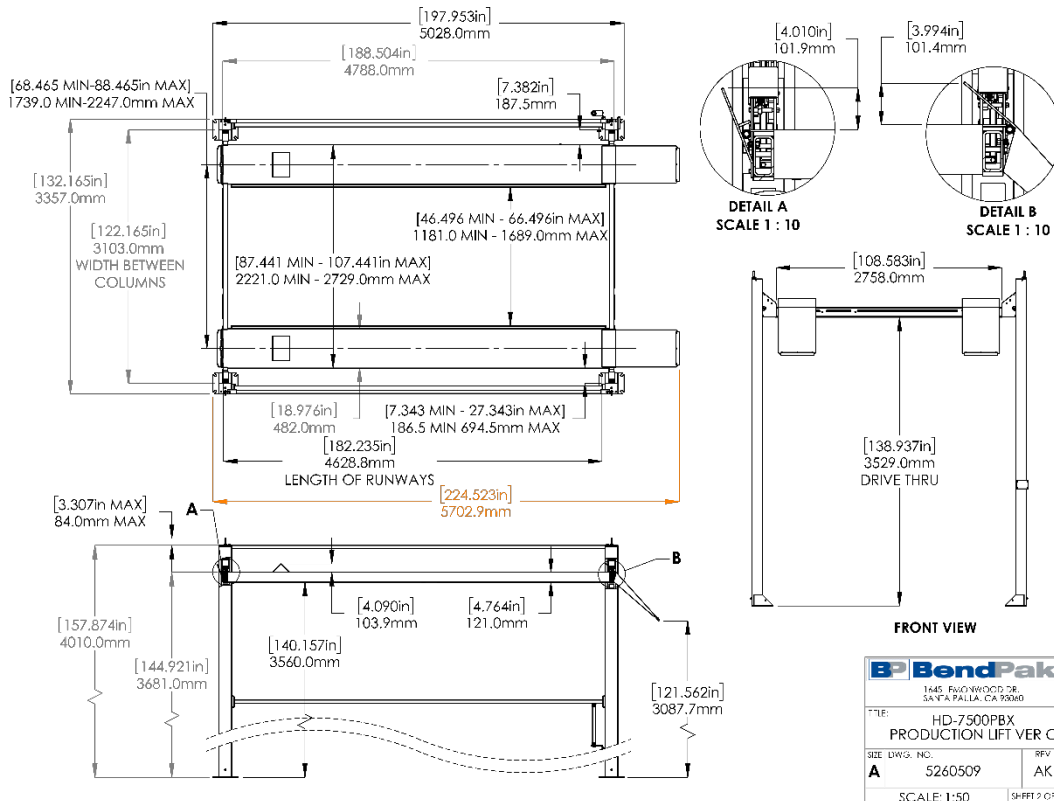

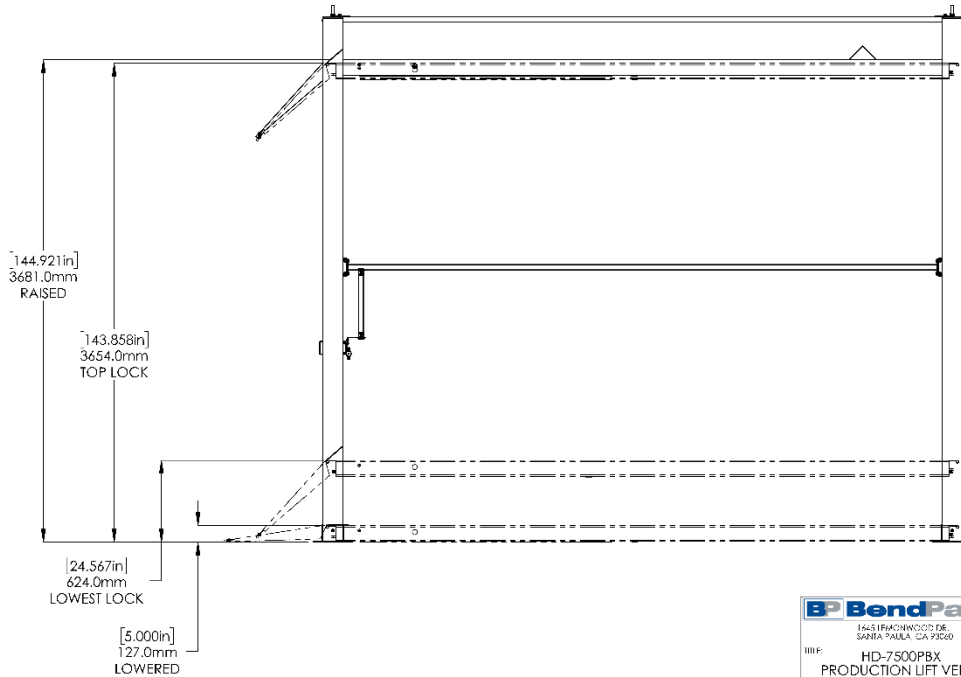

1. ALL DIMENSIONS SHOWN ARE WITH LOCK LADDER ADJUSTED ALL THE WAY UP
2. SAFETY LOCK POSITIONS: 31
3. SPACED EVERY: 101.0mm / 3.976"

BendPak
1645 BENDWOOD DR.
SANTA PAULA, CA 95600

IMP: HD-7500PBX
PRODUCTION LIFT VER C

SIZE DWG. NO. 5260509 REV. AK

SCALE: 1:30 SHEET 3 OF 3

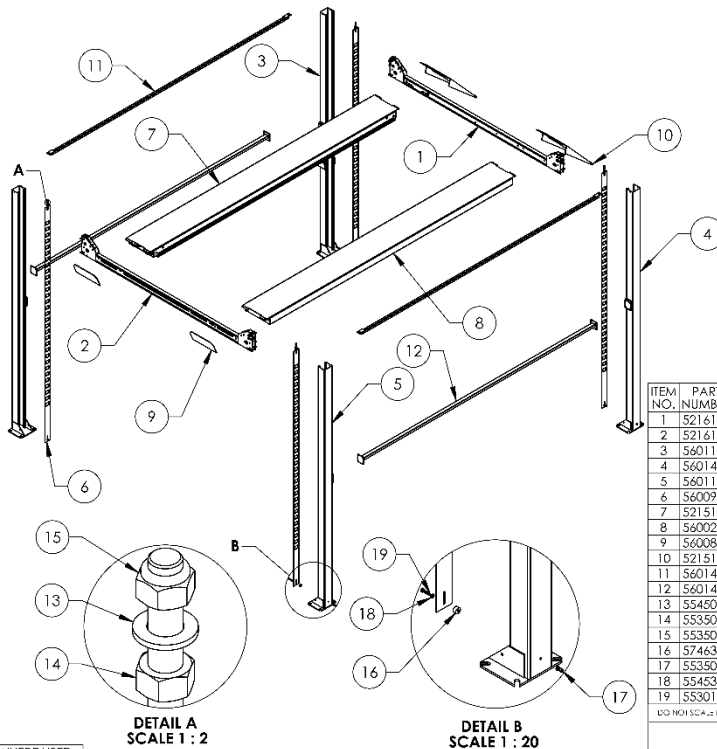

WHERE USED
HD-7500PBX

DETAIL A
SCALE 1 : 2

DETAIL B
SCALE 1 : 20

NOTE: UNLESS OTHERWISE SPECIFIED

1. REFER TO MODEL FOR ADDITIONAL INFORMATION
2. SEE SHIPPING INSTRUCTIONS FOR FINAL PACKAGING
3. THREAD M16 HARDWARE ONTO LADDER BOLTS AS SHOWN

ITEM NO.	PART NUMBER	DESCRIPTION	QTY	REV
1	5216159	HD-7500 CROSSTUBE ASSEMBLY, SMALL WINDOW	1	A
2	5216160	HD-7500PBX CROSSTUBE ASSEMBLY, LARGE WINDOW	1	A
3	5601140	HD 7PX/7500PBX POWER SIDE POST WELDMENT	1	D
4	5601410	HD-7PX/7500 POST WELDMENT, R.H	2	C
5	5601139	HD-7PX/7500PBX POST WELDMENT	1	D
6	5600921	HD-7/973/7500 SAFETY LADDER WELDMENT	4	C
7	5215171	HD-7PX/7500 POWER SIDE RAMP ASSEMBLY	1	AE
8	5600206	HD 7PX/7500 OFF SIDE RAMP WELDMENT	1	J
9	5600890	HD-7/7500/9/PL-12000 TIRE STOP PLATE WELDMENT	2	F
10	5215193	HD-7/9/7500BL DRIVE UP RAMP ASSEMBLY	2	G
11	5601409	HD-7PX/7500 TOP STIFFENER TUBE WELDMENT	2	A
12	5601411	HD-7PX/7500 STIFFENER TUBE WELDMENT	2	A
13	5545025	WASHER M16 x 30 FLAT, CL 10.9	4	-
14	5535021	NUT M16 x 2.0, CL 10.9	4	-
15	5535008	NUT M16 x 2.0 NL, CL 10.9	4	-
16	5746381	HD-7/7500/ 9 SPACER, SAFETY LADDER, 17.5mm LG	4	B
17	5535013	NUT M10 x 1.5 NL, CL10.9	4	-
18	5545341	WASHER M10 x Ø20 FLAT, CL10.9	8	-
19	5530167	HHB M10 x 1.5 x 45 FT. CL 10.9	4	-

ISO 9001:2015 CERTIFIED

NAME DATE

DRAWN TMI 06/11/2014

CHECKED:

DIMENSIONS ARE IN MM

THIRD ANGLE PROJECTION



FILE: HD-7500PBX LIFT SUPERSTRUCTURE

SIZE DWG. NO. 5245391 REV. AD

SCALE: 1:60 SHEET 1 OF 1

NEXT ASSEMBLY
5260509

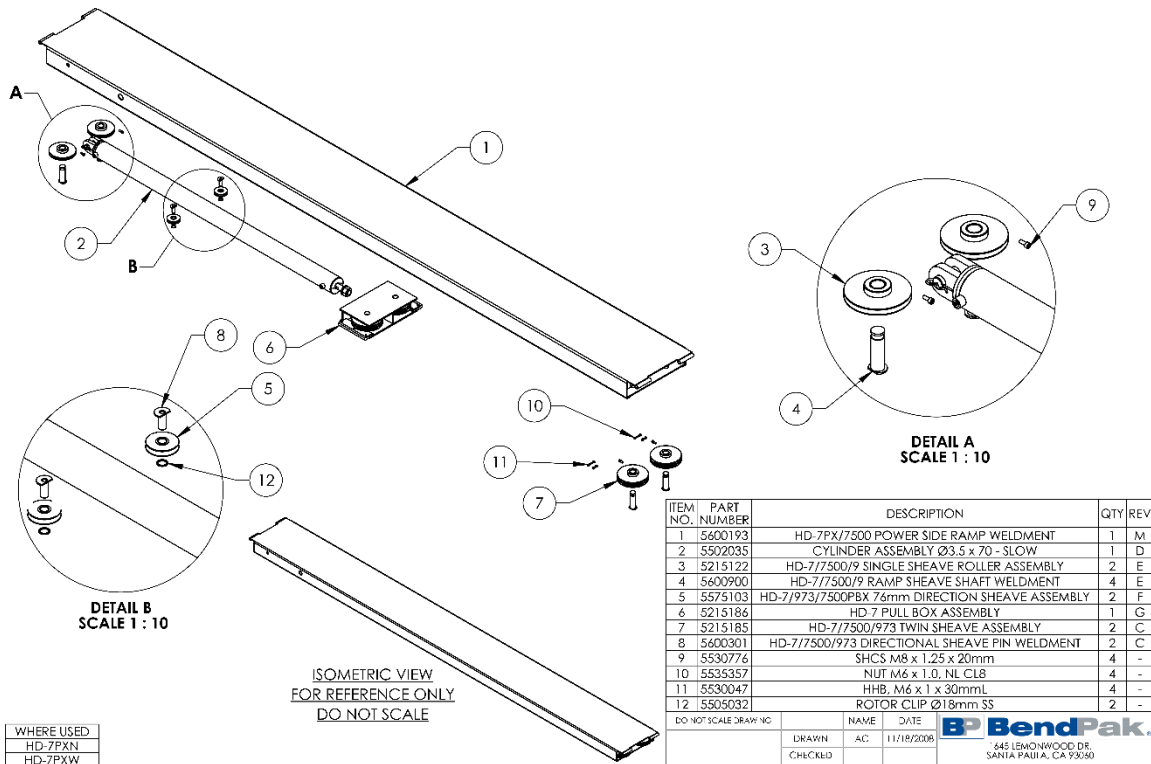

NOTE: UNLESS OTHERWISE SPECIFIED

- REFER TO MODEL FOR ADDITIONAL INFORMATION
- SEE SHIPPING INSTRUCTIONS FOR FINAL PACKAGING ASSEMBLE ITEMS AS SHOWN

NEXT ASSEMBLY
5245244
5245385
5245386
5245391

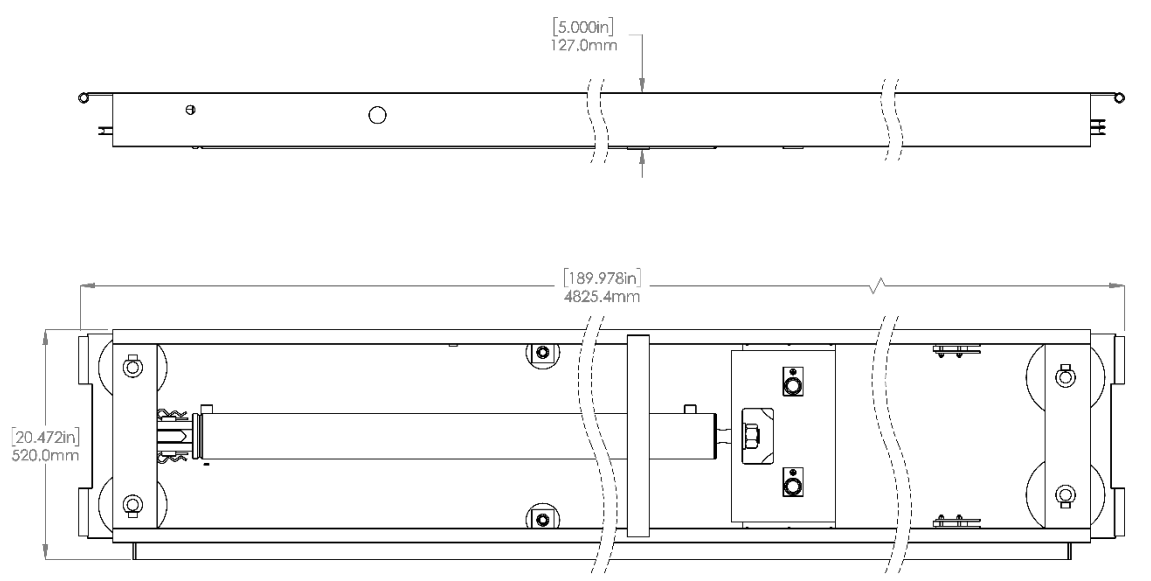

BP BendPak
1445 LEMONWOOD DR. SANTA PAULA, CA 93050
TITLE: HD-7PX/7500 POWER SIDE RAMP ASSEMBLY
SIZE: A DWG. NO. 5215171 REV AE
SCALE: 1:10 SHEET 2 OF 2

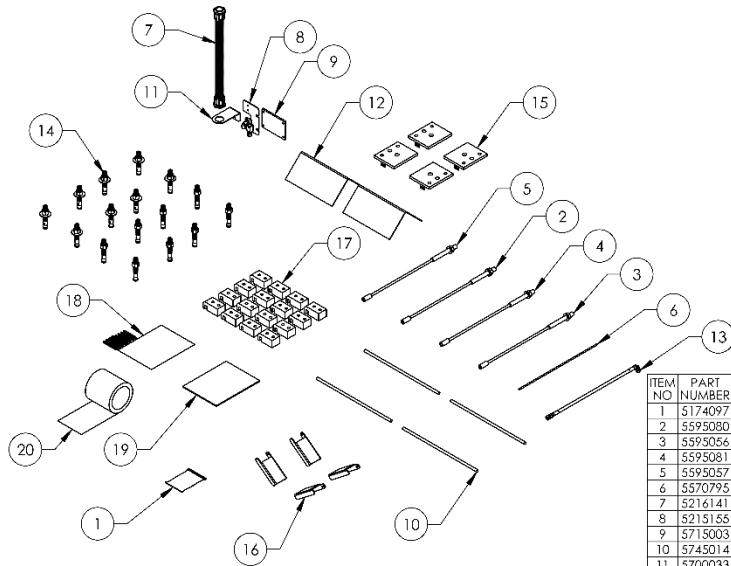

WHERE USED
HD-7500PBX

NOTE: UNLESS OTHERWISE SPECIFIED

1. SEE SHIPPING INSTRUCTIONS FOR FINAL PACKAGING
2. HOSES AND CABLES IN REPRESENTATIONAL FORM
3. (*) LENGTH FOR REFERENCE ONLY

ITEM NO	PART NUMBER	DESCRIPTION	QTY.	REV
1	5174097	HD-7PX/7500 PARTS BAG	1	H
2	5595080	HD-7500PBX CABLE ASSEMBLY Ø10 x 5620mm SI	1	D
3	5595056	HD-7500PBX CABLE ASSEMBLY Ø10 x 7868mm ST	1	D
4	5595081	HD-7500PBX CABLE ASSEMBLY Ø10 x 10400mm ST	1	D
5	5595057	HD-7500PBX CABLE ASSEMBLY Ø10 x 12664mm ST	1	D
6	5570795	1/4" POLY-FLO TUBING	20000*	mm
7	5216141	FLEX TUBE KIT, UP TO 3000mm	1	A
8	5215155	HD-777500 FLEX TUBE BRACKET ASSY	1	G
9	5715003	POWER UNIT VIBRATION DAMPENER	1	B
10	5745014	HD-777500/9, PL-12000 DRIVE UP RAMP PIN	4	B
11	5700033	FL14/HD/HDS FLEX TUBE ANGLE	1	E
12	5700072	WHEEL CHOCK	2	B
13	5570876	HYDRAULIC HOSE ASSEMBLY Ø6.4 x 4090mm SB	1	F
14	5530456	AB 3/4" x 4 - 3/4"	16	-
15	5600255	HD-7PX POST TOP PLATE WELDMENT	4	C
16	5716630	HD-777500/9 CROSS-TUBE COVER, PLASTIC	4	A
17	5716005	CROSS-TUBE POLYETHYLENE SLIDE BLOCK	16	M
18	5210241	4 POST LIGHT DUTY CE PARTS BAG	1	A
19	5900174	HD-7500BLX/BLX INSTALLATION MANUAL	1	-
20	5930195	ANTI-SLIP TAPE, 6" x 24ft	1	-

ISO 1:20 SCALE DRAWING

NAME DATE
DRAWN TM 10/16/2020

CHECKED OK

THIRD ANGLE PROJECTION

PROPRIETARY AND CONFIDENTIAL
THIS DOCUMENT IS UNCLASSIFIED EXCEPT WHERE SHOWN OTHERWISE
THIS DOCUMENT IS UNCLASSIFIED EXCEPT WHERE SHOWN OTHERWISE
THIS DOCUMENT IS UNCLASSIFIED EXCEPT WHERE SHOWN OTHERWISE

BP BendPak.
1645 LEMONWOOD DR.
SANTA PAULA, CA 95060

TITLE: HD-7500PBX PARTS BAG

SIZE DWG. NO. REV
A 5250086 M

SCALE: 1:20 SHEET 1 OF 1

NEXT ASSEMBLY
5260509

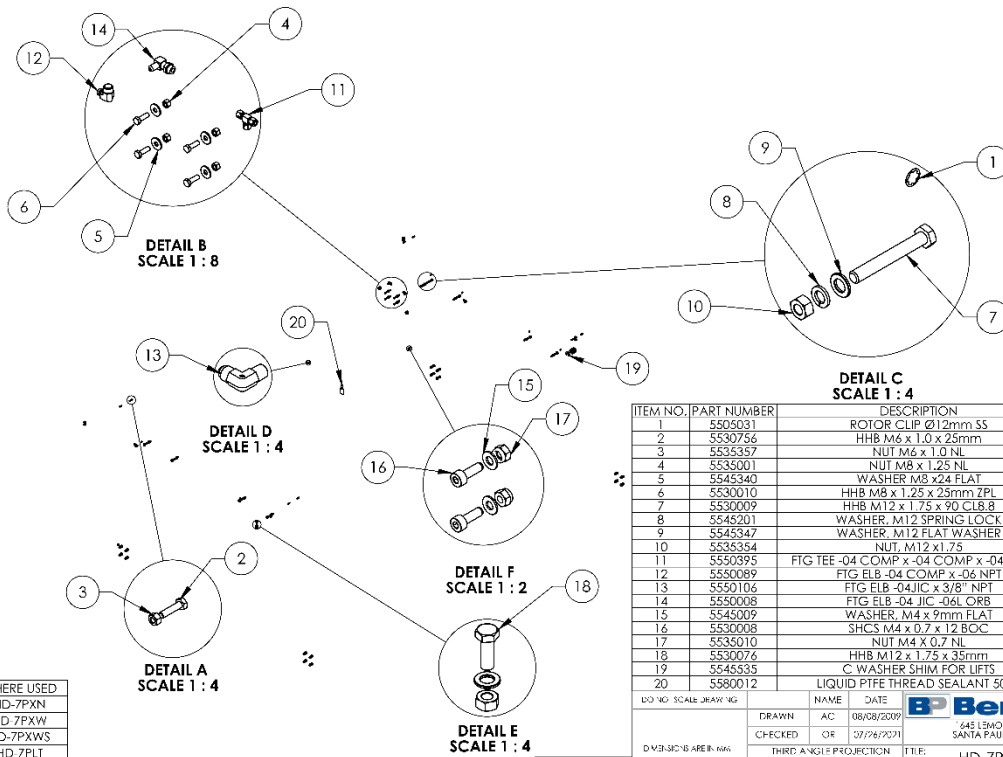

WHERE USED
HD-7PXN
HD-7PXW
HD-7PXWS
HD-7PLT
HD-7500PBX

NOTE: UNLESS OTHERWISE SPECIFIED

1. REFER TO MODEL FOR ADDITIONAL INFORMATION
2. SEE SHIPPING INSTRUCTIONS FOR FINAL PACKAGING

ITEM NO.	PART NUMBER	DESCRIPTION	QTY.	REV
1	5505031	ROTOR CLIP Ø12mm SS	8	-
2	5530756	HHB M6 x 1.0 x 25mm	8	-
3	5535357	NUT M6 x 1.0 NL	8	-
4	5535001	NUT M8 x 1.25 NL	4	-
5	5545340	WASHER M8 x24 FLAT	4	-
6	5530010	HHB M8 x 1.25 x 28mm ZPL	4	-
7	5530009	HHB M12 x 1.75 x 90 CLB.8	8	-
8	5545201	WASHER, M12 SPRING LOCK	8	-
9	5545347	WASHER, M12 FLAT WASHER	28	-
10	5535354	NUT, M12 x1.75	28	-
11	5550395	FIG TEE -04 COMP x -04 COMP x -04 COMP	3	-
12	5550089	FIG ELB -04 COMP x -06 NPT	2	-
13	5550106	FIG ELB -04 JIC x 3/8" NPT	1	-
14	5550008	FIG ELB -04 JIC -04L ORB	1	-
15	5545009	WASHER, M4 x 9mm FLAT	2	-
16	5530008	SHCS M4 x 0.7 x 12 BOC	2	-
17	5535010	NUT M4 x 0.7 NL	2	-
18	5530076	HHB M12 x 1.75 x 35mm	20	-
19	5545335	C WASHER SHIM FOR LIFTS	19	-
20	5580012	LIQUID PTFE THREAD SEALANT 50ml	1	-

ISO 1:45 SCALE DRAWING

NAME DATE
DRAWN AC 08/08/2009

CHECKED OK 07/26/2021

THIRD ANGLE PROJECTION

PROPRIETARY AND CONFIDENTIAL
THIS DOCUMENT IS UNCLASSIFIED EXCEPT WHERE SHOWN OTHERWISE
THIS DOCUMENT IS UNCLASSIFIED EXCEPT WHERE SHOWN OTHERWISE
THIS DOCUMENT IS UNCLASSIFIED EXCEPT WHERE SHOWN OTHERWISE

BP BendPak.
1645 LEMONWOOD DR.
SANTA PAULA, CA 95060

TITLE: HD-7PX/7500 PARTS BAG

SIZE DWG. NO. REV
A 5174097 H

SCALE: 1:45 SHEET 1 OF 1

NEXT ASSEMBLY
5250086
5250161
5250166
5250342
5250352

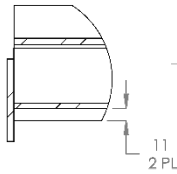
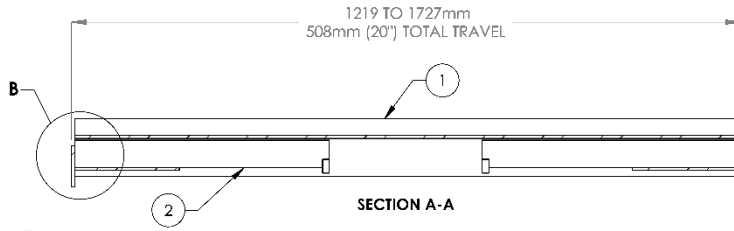
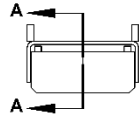
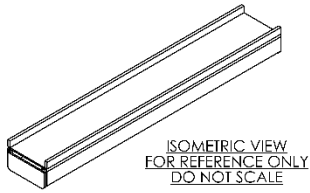

DETAIL B
SCALE 1 : 4

WHERE USED
HD-7500BLX
HD-75BXT

NOTE: UNLESS OTHERWISE SPECIFIED.

- REFER TO MODEL FOR ADDITIONAL INFORMATION
- BREAK AND DEBURR ALL SHARP EDGES 0.3mm
- REMOVE ALL WELD SPLATTER
- DIMENSIONS SHOWN ARE AFTER PAINTING
- PAINT BLACK (RAL-9017) 20% GLOSS

ITEM NO	PART NUMBER	DESCRIPTION	QTY	REV
1	5600732	TC-3000 PLATFORM WELDMENT	1	C
2	5600733	TC-3000 EXTENSION ARM	2	B
3	5735308	JP-6/TC-3000 SLIDE ARM GUIDE PLATE	2	B

ISO NOT SCALE DRAWING	NAME	DATE	 1645 LEMONWOOD DR. SAN ANTONIO, TX 78202
DRAWN	AM	07/19/2013	
CHECKED	OF	2/15/2023	TITLE: TC-3000 ASSEMBLY
THIRD ANGLE PROJECTION 			SIZE DWG. NO. REV A 5175801 D
NEXT ASSEMBLY 5260531 5260659			SCALE: 1:8 SHEET 1 OF 1

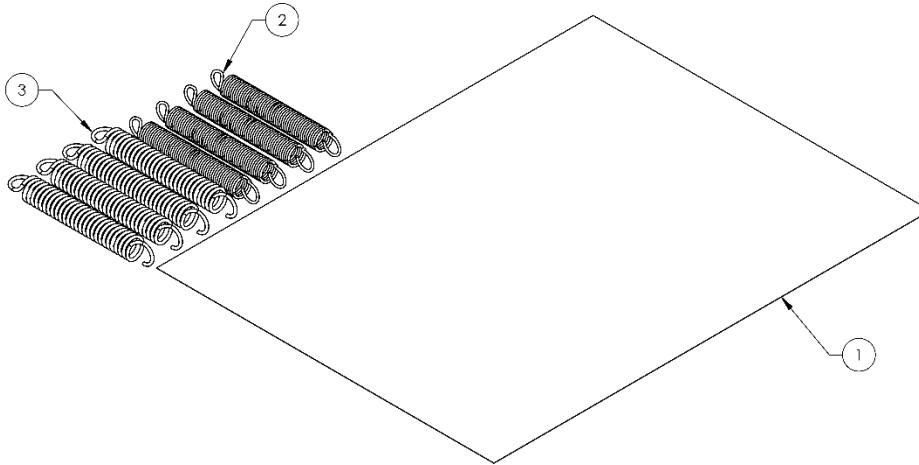

ITEM NO	PART NUMBER	DESCRIPTION	QTY	REV
1	5900247	SAFETY CE KIT INSTALLATION SHEET	1	-
2	5540070	SPRING Ø11mm x 84mm, AIR CYLINDER	4	C
3	5540065	SPRING Ø13mm x 90mm, SLACK SAFETY	4	A

WHERE USED	DRAWN	TM	DATE	 1645 LEMONWOOD DR. SAN ANTONIO, TX 78202
HD-7 SERIES	CHECKED	OR	08/28/2020	
HD-7500 SERIES	TITLE: 4 POST LIGHT DUTY CE PARTS BAG			SIZE DWG. NO. REV A 5210241 A
HD-9 SERIES	THIRD ANGLE PROJECTION 			SCALE: 1:2 SHEET 1 OF 1
PL-12000 SERIES	PROPRIETARY AND CONFIDENTIAL THE INFORMATION CONTAINED HEREIN IS THE PROPERTY OF BENDPAK INC. AND IS TO BE USED ONLY FOR THE PURPOSES SPECIFIED HEREIN. IT IS NOT TO BE REPRODUCED OR TRANSMITTED IN ANY FORM OR BY ANY MEANS, ELECTRONIC OR MECHANICAL, INCLUDING PHOTOCOPYING, RECORDING, OR BY ANY INFORMATION STORAGE AND RETRIEVAL SYSTEM.			
HD-14T	NEXT ASSEMBLY FL14 SERIES			

NOTE: UNLESS OTHERWISE SPECIFIED.

- SEE SHIPPING INSTRUCTIONS FOR FINAL PACKAGING

Automotive Lift Institute (ALI) Store

You probably checked the [ALI's Directory of Certified Lifts](http://www.autolift.org/ali-directory-of-certified-lifts/) before making your most recent Lift purchase, but did you know the [ALI Store](http://www.autolift.org/ali-store/) offers a wide variety of professional, easy-to-use, and reasonably priced training and safety materials that will make your garage a safer place to work?

The ALI Store is your trusted source for workplace safety!



Lifting It Right Online Certificate Course. Make sure you and your people are lifting vehicles the right way.



ALI Lift Inspector Certification Program Registration. Become a ALI Certified Lift Inspector.

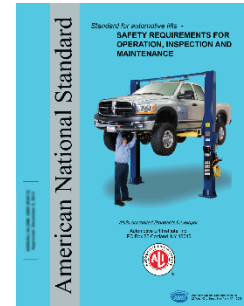

ANSI/ALI ALOIM Standard for Automotive Lifts. Safety Requirements for Operation, Inspection, and Maintenance.

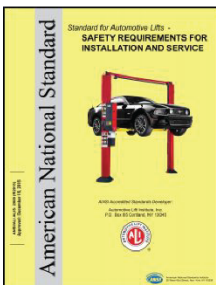

ANSI/ALI ALIS Standard. Safety Requirements for Installation and Service.



Guide to Identifying Vehicle Lifting Points for Frame-Engaging Lifts. Don't eyeball your lifting points, *know* where they are.



Lift Operator Safety Materials. Five safety documents in a single package.

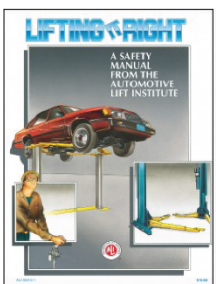

Lifting It Right. A hardcopy version of the *Lifting It Right* safety manual from the Automotive Lift Institute.

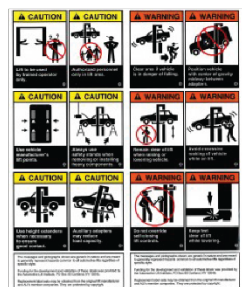

Uniform Warning Labels and Placards for 2-Posts. Labels in Mandarin, French Canadian, and Spanish are also available.



Safety Tips Card. Reminds your people of 13 key safety tips to follow daily.

Visit today and get the training and materials you need to work safely:
www.autolift.org/ali-store/.

