

Double- and Triple-Wide Parking Lifts

Installation and Operation Manual

Manual P/N 5900056 — Manual Revision D1 — April 2022

Models:

- PL-6KDT
- PL-6KDTX-21
- PL-6KDW
- PL-6KT

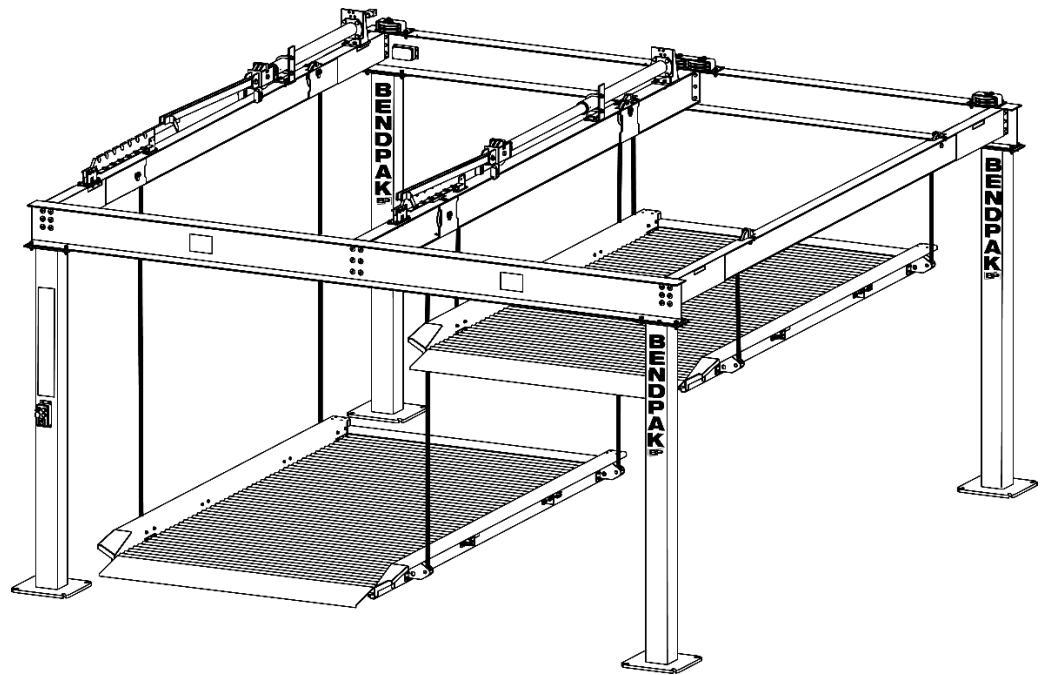

Model PL-6KDT shown.

Designed and engineered by BendPak Inc. in Southern California, USA. Made in China.



IMPORTANT SAFETY INSTRUCTIONS, SAVE THESE INSTRUCTIONS! Read the entire contents of this Manual **before** installing, operating, servicing, or maintaining this product. Failure to follow the instructions and safety precautions in this Manual can result in serious injury or death. Make sure all other operators also read this Manual. Keep the Manual near the product for future reference. **By proceeding with installation and operation, you agree that you fully understand the contents of this Manual and assume full responsibility for product use.**

Manual. PL-6K Series Parking Lifts, *Installation and Operation Manual*, Manual P/N 5900056, Manual Revision D1, Released April 2022.

Copyright. Copyright © 2022 by BendPak Inc. All rights reserved. You may make copies of this document if you agree that: you will give full attribution to BendPak Inc., you will not make changes to the content, you do not gain any rights to this content, and you will not use the copies for commercial purposes.

Trademarks. BendPak and the BendPak logo are registered trademarks of BendPak Inc. All other company, product, and service names are used for identification only. All trademarks and registered trademarks mentioned in this Manual are the property of their respective owners.

Limitations. Every effort has been made to ensure complete and accurate instructions are included in this Manual. However, product updates, revisions, and/or changes may have occurred since this Manual was published. BendPak reserves the right to change any information in this Manual without incurring any obligation for equipment previously or subsequently sold. BendPak is not responsible for typographical errors in this Manual. You can always find the latest version of the **manual for your product on the BendPak website**.

Warranty. The BendPak warranty is more than a commitment to you: it is also a commitment to the value of your new product. Contact your nearest BendPak dealer or visit www.bendpak.com/support/warranty for full warranty details. Go to bendpak.com/support/register-your-product/ and fill out the online form to register your product (be sure to click **Submit**).

Safety. Your Lift was designed and manufactured with safety in mind. However, your safety also depends on proper training and thoughtful operation. Do not install, operate, maintain, or repair the unit without reading and understanding this Manual and the labels on the unit; **do not use your Lift unless you can do so safely!**

Owner Responsibility. In order to maintain your product properly and to ensure everyone's safety, it is the responsibility of the product owner to read and follow these instructions:

- Follow all installation, operation, and maintenance instructions.
- Make sure product installation conforms to all applicable local, state, and federal codes, rules, and regulations, such as state and federal OSHA regulations and electrical codes.
- Read and follow all safety instructions. Keep them readily available for operators.
- Make sure all operators are properly trained, know how to safely operate the unit, and are properly supervised.
- Do not operate the product until you are certain that all parts are in place and operating correctly.
- Carefully inspect the product on a regular basis and perform all maintenance as required.
- Service and maintain the unit only with approved replacement parts.
- Keep instructions permanently with the product and make sure all labels are clean and visible.
- **Only use the Lift if it can be used safely!**

Unit Information. Enter the Model Number, Serial Number, and the Date of Manufacture from the Label on your unit. This information is required for part or warranty issues.

Model: _____

Serial: _____

Date of Manufacture: _____

BP BendPak Santa Paula, CA USA www.bendpak.com	
MODEL NUMBER	
DESCRIPTION	
LIFT CAPACITY	DATE OF MFG.
VOLTAGE	SERIAL NUMBER
<input type="checkbox"/> 110-240V, 50-60 Hz, 1 Ph	UPC
<input type="checkbox"/> 208-240V, 50-60 Hz, 1 Ph	
<input type="checkbox"/> 380-415V, 50-60 Hz, 3 Ph	
<input type="checkbox"/> 208-440V, 50-60 Hz, 3 Ph	
DANGER! Disconnect Power Before Servicing	
WARRANTY VOID IF DATA PLATE IS REMOVED PN 5905951	
EAC	

Table of Contents

Introduction	3	Installation	12
Shipping Information	4	Operation	50
Safety Considerations	4	Maintenance	53
Components	7	Troubleshooting	55
FAQs	8	Wiring Diagrams	57
Will My Car Fit?	9	Labels	61
Specifications	10	Parts Drawings	64
Installation Checklist	11	Maintenance Logs	81

Introduction

This Manual describes the PL-6K Series of parking lifts, which let you park double or triple the number of Vehicles in a parking area. Each Platform supports up to 6,000 lbs. (2,722 kg).

There are four models in the PL-6K Series:

- **PL-6KDT:** Parking Lift with two independent Platforms.
- **PL-6KDTX-21:** Wide Parking Lift with two independent Platforms. *Special order only.*
- **PL-6KDW:** **Extra wide** Parking Lift with two independent Platforms.
- **PL-6KT:** Parking Lift with three independent Platforms.

All models are similar, so if no distinction is made, then the information applies to all models. If information applies to only one model, that distinction is mentioned in text.

More information about the full line of BendPak products can be found at bendpak.com.

This Manual is mandatory reading for all users of PL-6K Series Lifts, including anyone who installs, uses, maintains, repairs, or wants to know more about them.

 DANGER Be extremely careful when installing, operating, maintaining, or repairing this equipment; failure to do so could result in property damage, product damage, injury, or (in very rare cases) death. Make sure only authorized personnel operate this equipment. All repairs must be performed by an authorized technician. Do not make modifications to the unit; this voids the warranty and increases the chances of injury or property damage. Make sure to read and follow the instructions on the labels on the unit.

Keep this Manual on or near the equipment so that anyone who uses or services it can read it.

If you are having issues, refer to the **Troubleshooting** section of this Manual for assistance.

Technical support and service is available from your dealer, on the Web at bendpak.com/support, by email at support@bendpak.com, or by phone at **(800) 253-2363**, extension 196.

You may also contact BendPak for parts replacement information (please have the model and serial number of your unit available) at **(800) 253-2363**, extension 191.

Shipping Information

Your equipment was carefully checked before shipping. Nevertheless, you should thoroughly inspect the shipment **before** you sign to acknowledge that you received it.

When you sign a bill of lading, it tells the carrier that the items on the invoice were received in good condition. **To protect yourself, do not sign until after you have inspected the shipment.** If any of the items listed on the bill of lading are missing or are damaged, do not accept the shipment until the carrier makes a notation on the bill of lading that lists the missing and/or damaged goods.

If you discover missing or damaged goods **after** you receive the shipment and have signed the bill of lading, notify the carrier at once and request the carrier to make an inspection. If the carrier will not make an inspection, prepare a signed statement to the effect that you have notified the carrier (on a specific date) and that the carrier has failed to comply with your request.

It is difficult to collect for loss or damage after you have given the carrier a signed bill of lading. If this happens to you, file a claim with the carrier promptly. Support your claim with copies of the bill of lading, freight bill, invoice, and photographs, if available. Our willingness to assist in helping you process your claim does not make us responsible for collection of claims or replacement of lost or damaged materials.

Safety Considerations

Read this Manual carefully before installing or using your new product. Do not install or operate the product until you are familiar with all operating instructions and warnings. Do not allow anyone else to operate it until they are familiar with all operating instructions and warnings. Keep this Manual on or near the product for future reference.

 **WARNING California Proposition 65.** This product can expose you to chemicals including styrene and vinyl chloride which are on the list of over 900 chemicals identified by the State of California to cause cancer, birth defects or reproductive harm. **Always** use this product in accordance with BendPak's instructions. For more information, visit www.p65warnings.ca.gov.

Important Safety Information

When using this equipment, basic safety precautions should always be followed, including:

- Read all instructions. Use only as described in this manual.
- Only operate your Lift between temperatures of 41°F to 104°F (5°C to 40°C).
- Make sure all operators read and understand this *Installation and Operation Manual*. **Keep the manual near the Lift at all times.**
- The Lift should only be operated by authorized personnel. Keep children and untrained personnel away from the Lift.

-
- Do not make any modifications to the Lift; this voids the warranty and increases the chances of injury or property damage. Use only factory-approved attachments.
 - Do not use the Lift while tired or under the influence of drugs, alcohol, or medication.
 - Do not touch hot parts; you could be burned. Always use care with the equipment.
 - Do not operate equipment with a damaged cord or if the equipment has been dropped or damaged – until it has been examined by a qualified service person.
 - Do not let a cord hang over the edge of a table, bench, or counter or come in contact with hot manifolds or moving fan blades. Loop the power cord around equipment when storing.
 - If an extension cord is necessary, a cord with a current rating equal or greater than that of the equipment should be used. Cords rated for less current than the equipment may overheat. Care should be taken to arrange the cord so that it will not be tripped over or pulled out.
 - Always unplug equipment from electrical outlets when not in use. Never use the cord to pull the plug from the outlet. Grasp plug and pull to disconnect.
 - To reduce the risk of a fire, do not operate equipment in the vicinity of open containers of flammable liquids (like gasoline).
 - Adequate ventilation should be provided when working on operating internal combustion engines.
 - Keep hair, loose clothing, fingers, and all parts of the body away from moving parts.
 - To reduce the risk of electric shock, do not use the unit on wet surfaces or expose to rain.
 - **Always wear safety glasses!** Everyday glasses only have impact resistant lenses, they are not safety glasses.

Save these instructions!

Additional Safety Information

The following safety information applies to all BendPak PL-6K Series models:

- PL-6K Series Lifts are Parking Lifts. **Use them only for their intended purpose.**
- The Lift should only be operated by authorized personnel. Keep children and untrained personnel away from the Lift.
- You must wear OSHA-approved (publication 3151) personal protective equipment at all times when installing, using, maintaining, or repairing the Lift. Leather gloves, steel-toed work boots, eye protections, back belts, and hearing protection are **mandatory**.
- The Control Box must be kept in the **Off** Position when the Lift is not in use.
- **Never** exceed the rated capacity of the Lift.
- When the Lift is in use, keep hands and all body parts well away from it.
- Keep loads balanced on the Lift Arm Assemblies. Clear the area immediately if a Vehicle is in danger of falling off the Lift. Do not make modifications to the Lift.
- Modifications void the warranty and increases the chances of injury or property damage. **Do not modify any safety-related features in any way.**
- The Lift uses electrical energy; if your organization has Lockout/Tagout policies, make sure to implement them after connecting the Lift to a power source.
- When handling the Hydraulic components, **always wear safety gloves!** In rare cases, a needle-like stream of Hydraulic Fluid (even at low pressure) can penetrate fingers, hands, or arms. Such a puncture can feel like a bite, electric shock, or a prick. While it may seem like a minor issue, any amount of Hydraulic Fluid injected into the human body is a serious issue. Anyone suffering such a puncture wound should be **immediately** taken to as an emergency to the hospital to determine the extent of the injury. Explain the circumstances of the injury to the attending

physician, including what type of Hydraulic Fluid was involved. Do not assume a puncture wound that could have been caused by Hydraulic Fluid is a minor issue; it could be life-threatening.

- Make a visual inspection of the Lift before using it. Do not use the Lift if you find any missing or damaged parts. Instead, take it out of service, then contact an authorized repair facility, your distributor, or BendPak at **(805) 933-9970** or email support@bendpak.com.
- BendPak recommends making a **thorough** inspection of the Lift at least once a year. Replace any damaged or severely worn parts, decals, or warning labels.

Symbols

Following are the symbols used in this Manual:

 **DANGER** Calls attention to an immediate hazard that **will** result in death or severe injury.

 **WARNING** Calls attention to a hazard or unsafe practice that **could** result in death or severe personal injury.

 **CAUTION** Calls attention to a hazard or unsafe practice that could result in minor personal injury, product damage, or property damage.

NOTICE Calls attention to a situation that, if not avoided, could result in product or property damage.



Tip

Calls attention to information that can help you use your product better.

Liability Information

BendPak Inc. assumes **no** liability for damages resulting from:

- Use of the equipment for purposes other than those described in this Manual.
- Modifications to the equipment without prior, written permission from BendPak.
- Modifying, disabling, overriding, or removing safety features.
- Damage to the equipment from external influences.
- Incorrect operation of the equipment.

Components

The components of your Lift include:

- **Control Box.** Houses the controls that raise and lower Platforms.
- **Control Post.** The Post on which the Control Box is mounted.
- **Power Unit.** Provides hydraulic power to the Hydraulic Cylinders that raise and lower Platforms.
- **Power Post.** The Post on which the Power Unit is mounted.
- **Approach Ramps.** One for each Platform. Use them to drive onto and off of Platforms.
- **Platforms.** The metal surface that holds raised Vehicles. All four Tires of the Vehicle **must** fit on the Platform.
- **Front and Rear Beams.** Part of the Lift structure. The Front Beam is on the opposite side from the Approach Ramps. The Rear Beam is above the Approach Ramps (the Approach end).
- **Crossbeams.** Also part of the Lift structure. The Powerside Crossbeam and the Center Crossbeam(s) both support a Hydraulic Cylinder and Safety Lock on top. The Offside Crossbeam is part of the structure of the Lift.
- **Offside Posts.** All four Posts are part of the structure of the Lift. The Control Post and the Power Post have special functions, mentioned above; the Offside Posts are part of the structure.

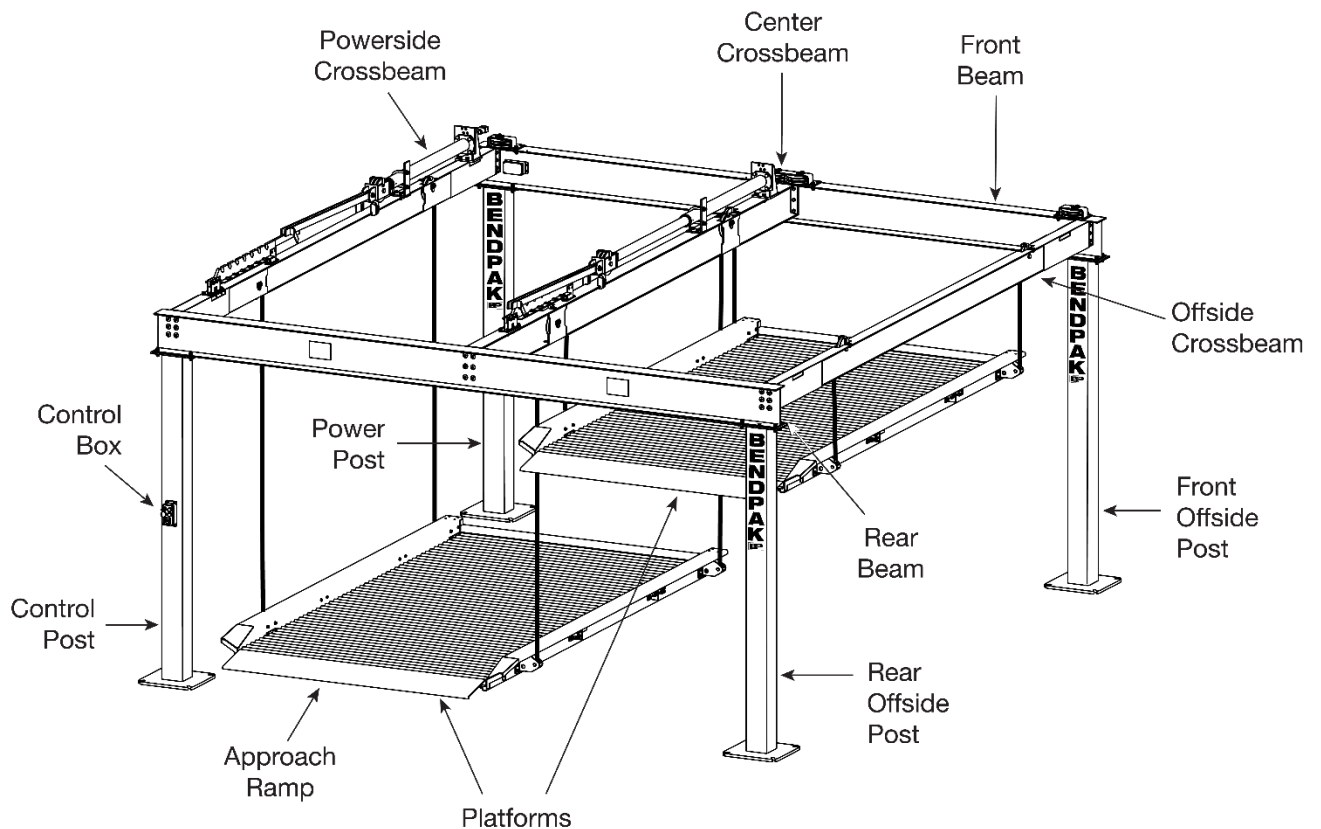

Model PL-6KDT shown; the PL-6KDW is wider and the PL-6KT has a third Platform and a second Center Crossbeam.

Frequently Asked Questions

Question: What kinds of vehicles can I park on my PL-6K Series Lift?

Answer: Cars, light trucks, and SUVs; up to 6,000 lbs. (2,722 kg) per Platform.

Q: Does the Lift have to be anchored in place?

A: Yes. The Posts **must** be anchored.

Q: Can I use my Lift to store boxes of stuff instead of a Vehicle?

A: No. This is *not* the intended use of the Lift; it is *not* designed to be used in this manner.

Q: How high does my garage ceiling have to be to support my Vehicles?

A: It depends on the height of the Vehicles you are putting on the Platforms. If you are parking low-slung Vehicles, then your ceiling does not have to be as high as it would need to be if you are parking taller Vehicles. Refer to **Will My Car Fit?** for additional information.

Q: Does the Control Box have to be on the Control Post?

A: Yes. That location gives the operator a clear view of the Platforms as they are raised and lowered.

Q: Does it matter if I drive my Vehicles in front first or back them in?

A: No. Your Lift works great either way. Make sure to park all Vehicles in the middle of the Platform, width-wise, no matter which way you drive them in.

Q: Will the 'Cables' really hold my vehicles?

A: Yes. PL-6K Series Lifts use 3/8 inch, aircraft-quality **wire rope** that runs through oversized Sheaves, reducing friction on them and extending their life with minimal maintenance.

Q: How long can I leave a Vehicle on a raised Platform?

A: As long as you want. Once a Safety Lock is engaged, gravity holds it in position, so a loss of power does not impact it. Your Vehicle is going to stay where you left it. Remember to **always leave Platforms either on the ground or engaged on their Safety Locks.**

Will My Car Fit?

Your Lift accommodates a wide variety of cars, light trucks, and SUVs.

Width

Considerations for Vehicle width include:

- **Platform width.** The usable width of the Platform is 82 inches / 2,082 mm; your tires cannot be wider than this. **All four tires must be fully on the Platform**, they cannot be on the side structure or on the Ramp. Always center your Vehicles on the Platform, width-wise.
- **Mirrors.** Mirrors and other accessories may mean that some parts of a Vehicle are much wider than the rest of the Vehicle. Parking lifts are designed to have lots of open space, but if you are parking two Vehicles next to each other that both have wide mirrors or other accessories, make sure they do not hit each other.
- **Car doors.** Opening Vehicle doors makes the Vehicle wider while they are open. Generally you want to avoid opening the doors of multiple Vehicles parked next to each other at the same time. You cannot open a car door while the Vehicle is raised, so this is not an issue for raised Vehicles.

Length

Considerations for Vehicle length include:

- **Platform length.** The usable length of the Platform is 150 inches / 3,802 mm; your wheelbase cannot be longer than this. **All four tires must be fully on the Platform**, they cannot be on the Ramp or the Tire Stop.
- **Overhang.** If a Vehicle's tires are fully on the Platform, then the parts of the Vehicle hanging over the Front Tire Stop or the Ramp are not a concern, as long as they do not hit anything.

Height

Considerations for Vehicle height include:

- **Ceiling height.** The height of your ceiling determines how much space you can allocate to the two Vehicles. If you want to park a tall Vehicle on a Platform *and* under the Platform, your ceiling is going to have to be higher than if you want to park two low-slung Vehicles.
- **Formula.** There's a formula for figuring out how much height you need, based on the Vehicles you want to park.

Height of Vehicle on Platform + 9 inches (6 inches for the height of the Platform plus 3 inches to get off the Safety Lock) + the height of the Safety Lock position of Platform.

Add these together; your garage height needs to be higher than the sum of these values.

To find the "height of Safety Lock position of Platform", raise a Platform and lock it on its Safety Lock position, then measure from the ground to the bottom of the raised Platform. Note that the Maximum Rise height listed in **Specifications** is how high the mechanism can go before stopping; the Safety Lock height is close to, **but not the same as**, Maximum Rise.

Specifications

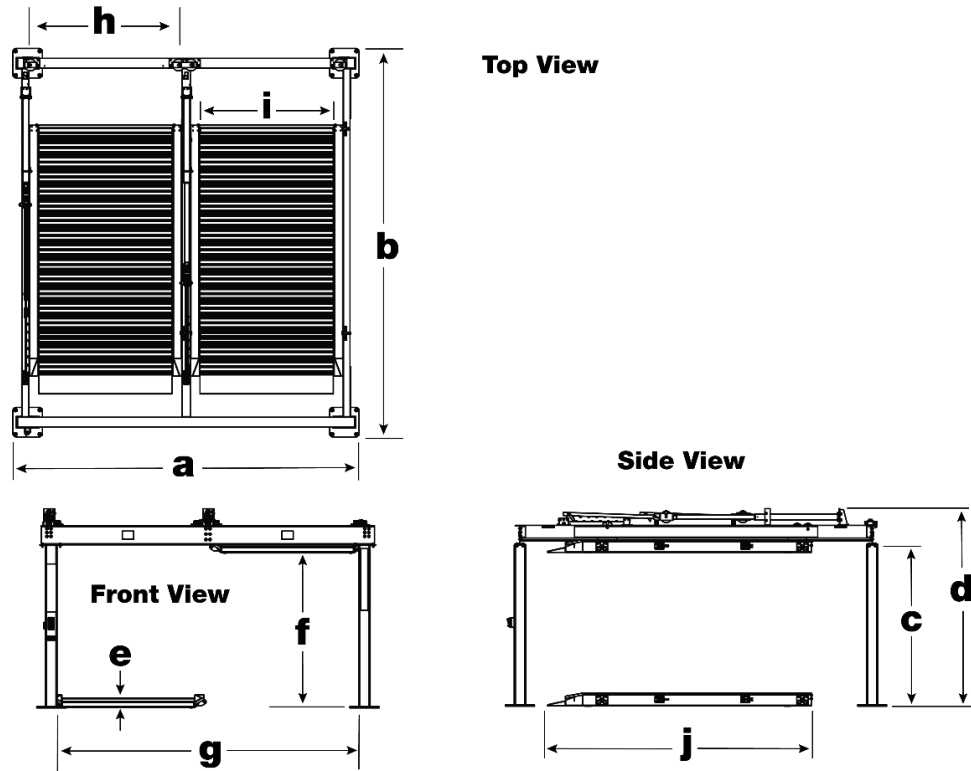

Model	PL-6KDT	PL-6KDTX-21	PL-6KDW	PL-6KT
# of Platforms	2	2	2	3
Load capacity per Platform	6,000 lbs. / 2,722 kg			
a Total width	211" / 5,352 mm	250" / 6,350 mm	268" / 6,811 mm	308" / 7,834 mm
b Total length	236.5" / 6,008 mm			
c Post height	100.25" / 2,553 mm			
d Total height	123.75" / 3,117 mm			
e Min. runway height	8" / 206 mm			
f Maximum rise	95.25" / 2,420 mm			
g Width between Posts	185.5" / 4,715 mm	225" / 5,713 mm	243" / 6,174 mm	283" / 7,197 mm
h Drive-Thru Clearance	93" / 2,438 mm			
i Usable Platform width	82" / 2,086 mm			
j Platform length (with Approach ramp)	166" / 4,216 mm			
Safety Lock Positions	7			
Lifting time	≈45 seconds			
Motor	220 VAC, 50/60 Hz, 1 Ph			

Installation Checklist

Following are the steps needed to install a PL-6K Series Lift. Perform them in the order shown.

- 1. Review the installation Safety rules.
- 2. Make sure you have the necessary Tools.
- 3. Plan for electrical work.
- 4. Select the installation Location.
- 5. Unload and unpack the Lift Components.
- 6. Review the installation Orientation.
- 7. Create Chalk Line Guides for the Posts.
- 8. Move the Posts into position.
- 9. Prepare and install the Front Beam.
- 10. Install the Rear Beam.
- 11. Prepare and install the Offside Crossbeam.
- 12. Prepare and install the Center Crossbeam(s).
- 13. Prepare and install the Powerside Crossbeam.
- 14. Install the Power Unit.
- 15. Read about Hydraulic Fluid Contamination
- 16. Read about Thread Sealants.
- 17. Install and Connect the Hydraulic System.
- 18. Contact the Electrician.
- 19. Connect a Power Supply to the Power Unit (***Electrician required***).
- 20. Connect the Controls (***Electrician required***).
- 21. Install the Power Disconnect Switch and Thermal Disconnect Switch (***Electrician required***).
- 22. Anchor the Posts.
- 23. Assemble the Platform Structures.
- 24. Install the Platform Sections and install the Approach Ramp.
- 25. Perform an Operational Test.
- 26. Review the Final Checklist.
- 27. Leave the Manual for the owner/operator.

Installation

The installation process includes multiple steps. Perform them in the order listed.

 **WARNING** *Only use the factory-supplied parts that came with your Lift.* If you use parts from a different source, you void your Warranty and compromise the safety of everyone who installs or uses the Lift. If you are missing parts, visit bendpak.com/support or call **(800) 253-2363**, extension 191.

Safety

While installing this equipment, your safety depends on proper training and thoughtful operation.

 **WARNING** Do not install this equipment unless you have automotive Lift installation training. Always use proper lifting tools, such as a Forklift or Shop Crane, to lift heavy components. Do not install this equipment without reading and understanding this Manual and the Labels on the unit.

Only fully trained personnel should be involved in installing this equipment. Pay attention at all times. Use appropriate tools and lifting equipment. Stay clear of moving parts.

 **WARNING** You *must* wear OSHA-approved (publication 3151) appropriate protective equipment at all times during installation: leather gloves, steel-toed work boots, eye protection, back belts, and hearing protection are **mandatory**.

Tools

You may need some or all of the following tools:

- Rotary hammer drill (or similar)
- ¾ inch carbide bit (conforming to ANSI B212.15)
- Hammer and crow bar
- Four-foot level
- Open-end wrench set, SAE and metric
- Socket and ratchet set, SAE and metric
- Hex key wrench set
- Medium crescent and pipe wrenches
- Torque wrench
- Chalk line
- Medium-sized flat screwdriver
- Tape measure, 25 feet or above
- Needle-nose pliers
- Forklift, Shop Crane, or heavy-duty rolling dolly
- Sawhorses
- 12-foot ladder
- Red and White Lithium Grease

Planning for Electrical Work

You will need to have a licensed, certified Electrician available at some point during the installation.

Notify your Electrician in advance so that they come prepared with appropriate wire for connecting the Power Unit to the power source, a Power Disconnect Switch, a Thermal Disconnect Switch, and the wiring for the Control Box, Junction Box, and Solenoids. Refer to **Contact the Electrician** for more information.

NOTICE Wiring, conduit, Electrical Disconnect and Thermal Disconnect must be provided by the Electrician; it is **not** supplied with the Lift.

⚠ DANGER All wiring **must** be performed by a licensed, certified Electrician. Verify all electrical work conforms to all applicable local, state and federal codes, rules and regulations, such as state and federal OSHA regulations and electrical codes.

The Electrician needs to:

- **Connect a 220 VAC power source to the Power Unit.** A power source is required.
- **Install a Power Disconnect Switch.** Ensures you can quickly and completely interrupt electrical power to the Lift in the event of an electrical circuit fault, emergency situation, or when equipment is undergoing service or maintenance. You must put it within sight and easy reach of the Lift operator. Refer to **Install a Power Disconnect Switch** for more information.
- **Install a Thermal Disconnect Switch.** Ensures the equipment shuts down in the event of an overload or an overheated motor. Refer to **Install a Thermal Disconnect Switch** for more information.
- **Connect the Controls.** The Control Box houses the Controls that raise and lower each Platform. The Controls must be wired appropriately; refer to **Connect the Controls** for more information.

Select a Location

When selecting the location for your Lift, consider:

- **Architectural plans.** Consult the architectural plans for your desired installation location. Make sure there are no conflicts between what you want to do and what the plans show.
- **Available space.** Make sure there is enough space for the Lift: front, back, sides, and above. Refer to **Specifications** for measurements.
- **Overhead obstructions.** Check for overhead obstructions such as building supports, heaters, electrical lines, low ceilings, hanging lights, and so on. **You do not want your vehicles hitting obstructions.**
- **Power.** You need a 220 VAC power source available for the Power Unit.
- **Outdoor installations.** PL-6K Series Lifts are not designed to be installed outdoors. **Outdoor installation is prohibited.**
- **Shimming.** If your Concrete floor is not level and you are anchoring the Lift, you can use Shims under the bases of the Posts, as needed, to level the Lift. To estimate your Shim requirements, use a transit level and targets to check for flatness. Use the provided Shims as necessary.

NOTICE Do not shim a Post more than half an inch using the provided Shims. A maximum shim of 2 inches is possible by ordering optional Shim Plates. Contact BendPak at **(800) 253-2363**, extension 191. Please have the model and serial number of your Lift available.

-
- **Floor.** Only install the Lift on a flat, concrete floor; do not install on asphalt or any other surface. The surface must be level; do not install if the surface has more than three degrees of slope.

 **WARNING** Installing your Lift on a surface with more than three degrees of slope could lead to injury or even death. Only install PL-6K Series Lifts on a level floor, defined as no more than 3/8 of an inch difference over the installation area. If your floor is not level, consider making the floor level or using a different location.

- **Concrete specifications.** Do not install the Lift on cracked or defective concrete. Make sure the concrete is at least 4.25 inches thick, 3,000 PSI, and cured for a minimum of 28 days.

 **CAUTION** BendPak Lifts are supplied with installation instructions and concrete anchors that met the criteria set by the latest version of the American National Standard “Automotive Lifts – Safety Requirements for Construction, Testing, and Validation”, ANSI/ALI ALCTV. You are responsible for any special regional structural and/or seismic anchoring requirements specified by any other agencies and/or codes such as the Uniform Building Code (UBC) and/or International Building Code (IBC).

Be sure to check your floor for the possibility of it being a post-tension slab. In this case, contact the building architect before drilling. Using ground penetrating radar may help you find the tensioned steel.

 **WARNING** Cutting through a tensioned cable can result in injury or death. Do not drill into a post-tension slab unless the building architect confirms you are not going to hit tensioned steel or you have located it using ground penetrating radar. If colored sheath comes up during drilling, stop drilling immediately.

Unload and Unpack

Try to have the components of the Lift unloaded near the location where you will be installing it.

Once the components are unloaded, they are your responsibility to move around. As the Lift includes a number of heavy pieces, the closer you unload them to the installation location, the better off you are.

 **WARNING** **Some Lift components are very heavy;** if handled incorrectly, they can damage materials like tile, sandstone, and brick. Try to handle the Lift components just twice: once when delivered and once when moved into position. You must have a Forklift or Shop Crane to move them into position. Use care when moving them around.

 **WARNING** The Posts and Beams are delivered with stabilizing structures on each end. Use caution when removing these stabilizing structures; the Posts and Beams could shift or even fall. If they fall on a person, they could cause serious injury.

Review the Installation Orientation

The Front of your Lift, as with many Lifts, is the end **opposite** the Approach Ramps.

In the case of the PL-6K Series, the Power Unit and Power Post are at the Front, while the Approach Ramps, the Control Post, and the Control Box are at the Rear.

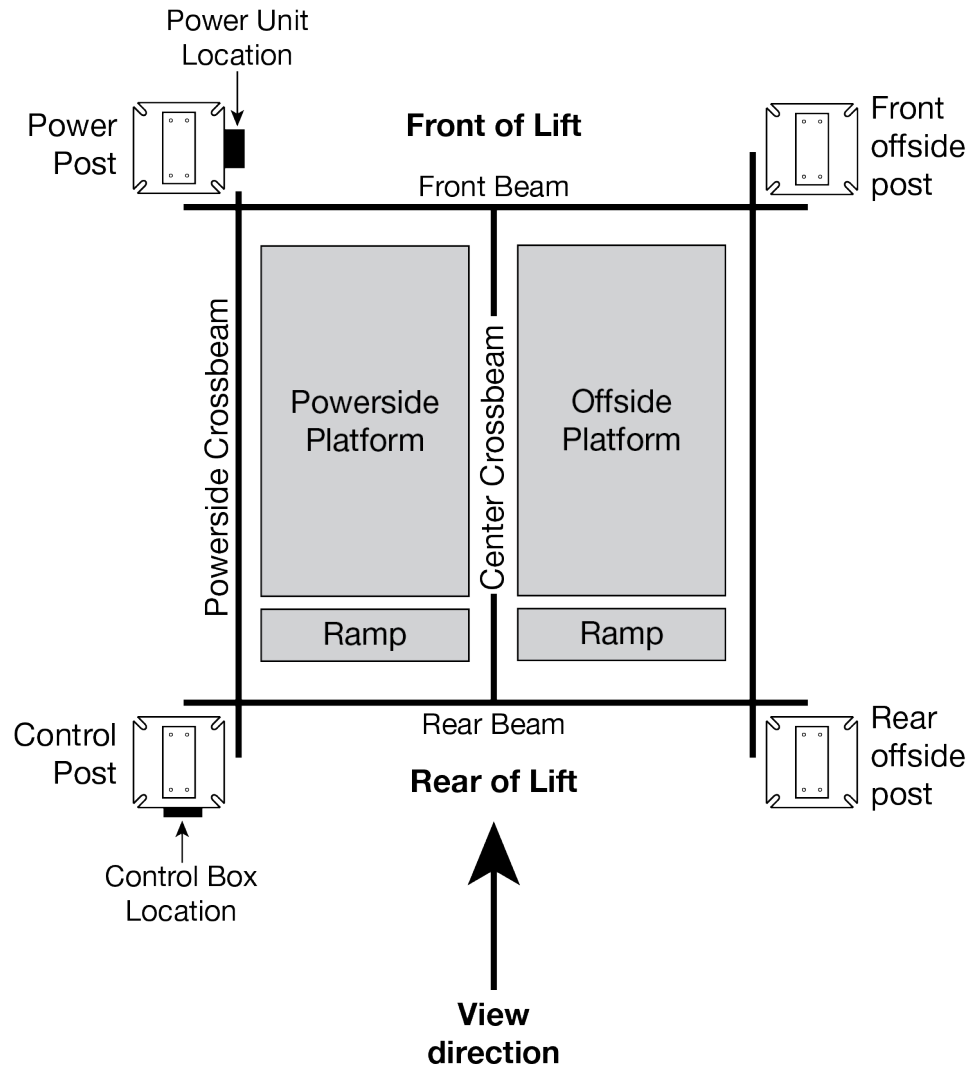

Drawing not necessarily to scale. The PL-6KT has a second Center Crossbeam and a third Platform called the Center Platform.

Put in Chalk Line Guides

Using Chalk Line Guides helps ensure the Posts get installed correctly. Refer to [Specifications](#) to determine the **Total Width** and **Total Length** for your Lift model.

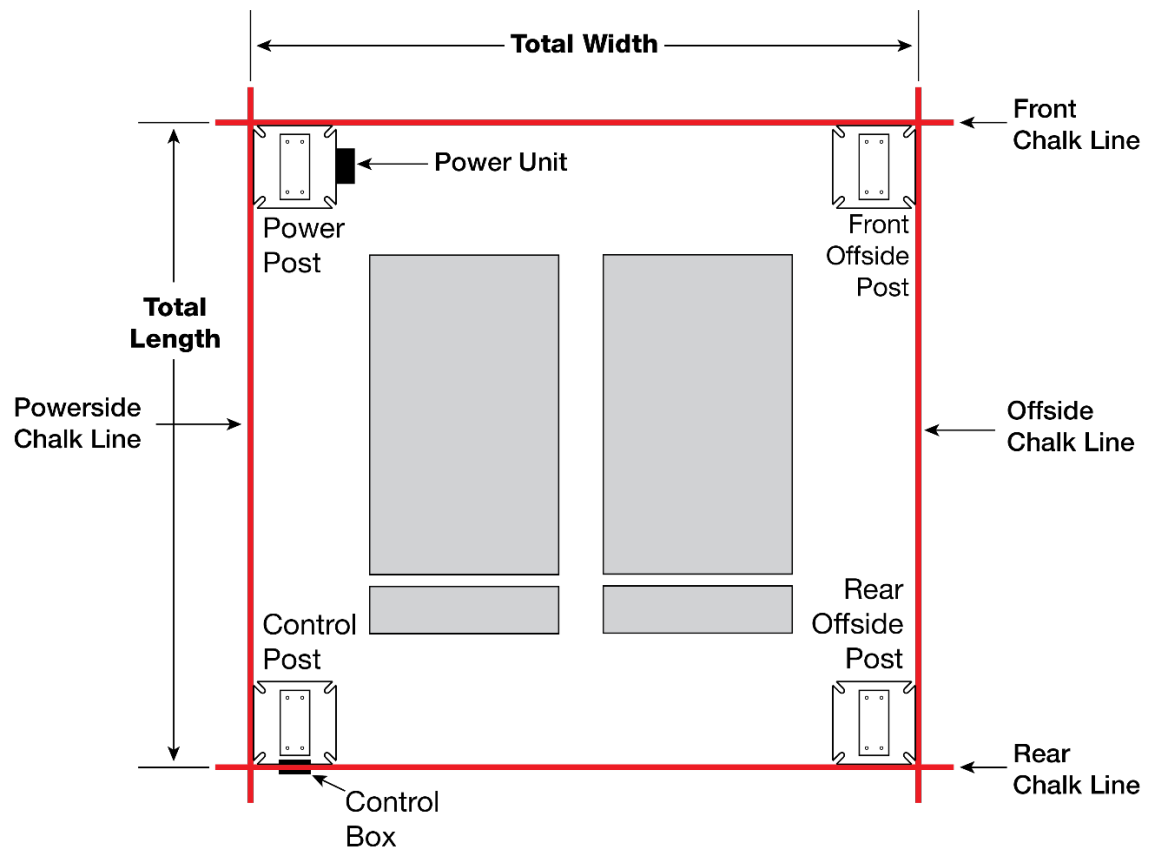

To create the Chalk Line Guides:

1. Create the Front Chalk Line where you want the Front of the Lift; make the Front Chalk Line longer than the **Total Width** setting for your Lift model.
2. Create the Powerside and Offside Chalk Lines at 90° angles to the Front Chalk Line and parallel to each other; make the Powerside and Offside Chalk Lines longer than the **Total Length** setting for your Lift model.

The Powerside and Offside Chalk Lines must also be exactly **x** distance from each other, **at both ends**, where **x** is the Total Width setting for your Lift model. *Measure to verify that this is true.*

3. Create the Rear Chalk Line parallel to the Front Chalk Line; make the Rear Chalk Line longer than the Total Width setting for your Lift model.

The Front and Rear Chalk Lines must also be exactly **x** distance from each other, **at both ends**, where **x** is the Total Depth setting for your Lift model. *Measure to verify that this is true.*

4. Before moving the posts into position, measure diagonally to make sure the two diagonals are the same. This ensures your layout is correct. **Do not forget to check the diagonals.**
5. When you move the posts into position, put the corners of the base plates inside the corners created by the four chalk lines.

Move the Posts into Position

BendPak strongly recommends using a Forklift or Shop Crane to move the Posts. You need to have at least three people work together to stand up the Posts.

⚠ DANGER The Posts are extremely heavy; be **very** careful when handling them. If they shift position or fall, they could cause serious injury. Only allow trained personnel move the Posts and use appropriate lifting devices, such as a Forklift or Shop Crane.

To move the Posts into position:

1. Using a Forklift or Shop Crane, move the Posts, *one at a time*, to the Chalk Line Guides you created.

Important: The Power Post and the Control Post are different from the Offside Posts. Make sure to position them at their **required** locations and orientations. Refer to the images in **Orientation** and **Components** for the locations and orientations of the Power and Control Posts. The Offside Posts are interchangeable; put them at either of the remaining Post locations.

2. Stand up each Post. **You must have three people work together to stand up a Post.**

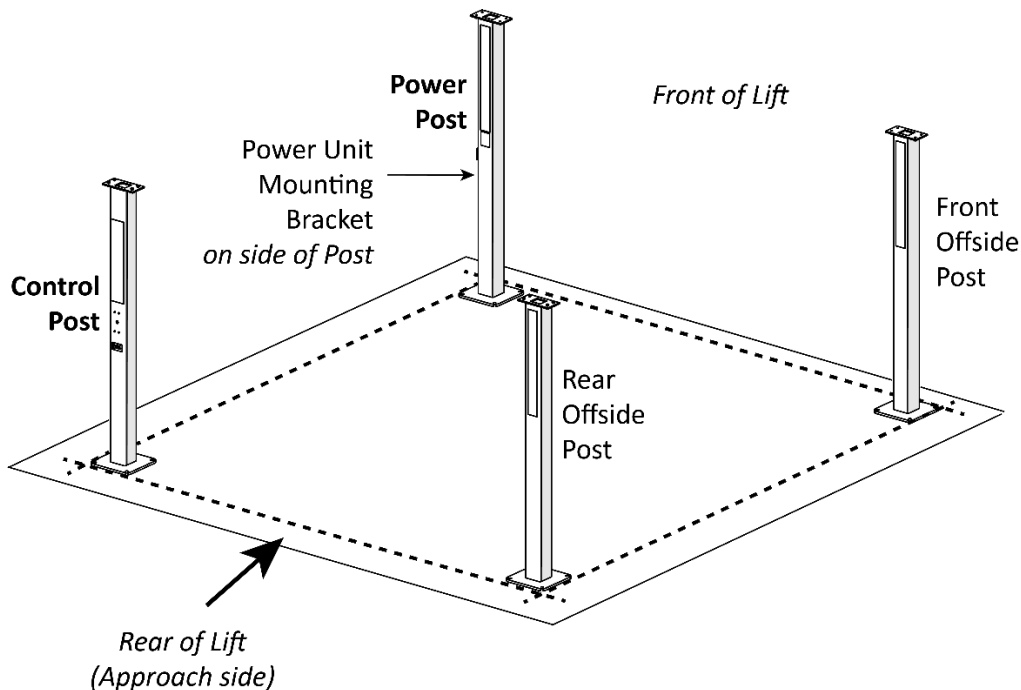

NOTICE You can shim and plumb the Posts now or later. Doing it now means the weight of the Beams and Crossbeams is *not* on the Posts, which makes it easier to shim them if you do it now. Doing it later mean you have some play in the Posts when you install the Beams and Crossbeams.

3. **Do not anchor the Posts at this point.**

Learn about the Beams

The next several sections describe how to prepare and install the Lift's Beams, Crossbeams, and Cabling.

There are two methods that are generally used to prepare and install the Beams/Crossbeams and route the Cables:

Method 1: Prepare each Beam/Crossbeam and raise them into place ***separately***.

In other words, prepare the Front Beam and raise it into place, prepare the Rear Beam and raise it into place, and so on until all the Beams and Crossbeams are in place. Most people who use this method route the Cables, as much as they can, for each Beam on the ground as they prepare it.

This method is generally best when you are tight on space. It requires additional work on ladders.

Method 2: Prepare the Beams/Crossbeams on the ground ***all at one time*** before raising them, including routing the Cables, then raise the entire structure into place all at once.

This method works if there is adequate space to raise the entire structure into place at one time. The advantage is that it reduces the amount of work you have to do on ladders at the end. This method requires at least one Shop Crane and one Forklift; your installation may require additional lifting devices.

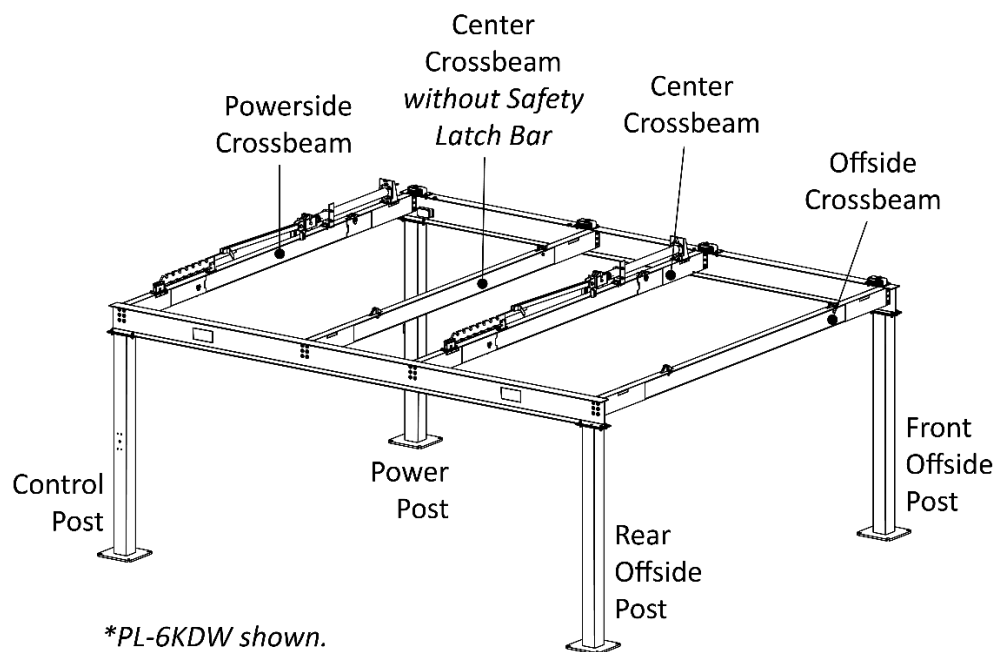

Choose the method that is best for your particular installation.



Tip

We recommend putting the Beams and Crossbeams on sawhorses when preparing the Beams/Crossbeams, no matter which method you choose. This generally makes them easier to prepare, compared to if they were on the ground.

The procedures in the next several sections assume the first method, preparing each Beam and Crossbeam separately, but they can be easily adapted to the second method.

Install the Front Beam

Before securing the Front Beam to the Lift Posts, you need to install the Sheave Assemblies on top. There are two Sheaves on the Powerside, four Sheaves in the center (two Double Sheaves), and two more Sheaves on the Offside. **Lubricate all Pins and Sheave Bearings with Red Lithium Grease as you assemble them.**

⚠ WARNING You must use a proper lifting device such as a Forklift or Shop Crane to raise and position the Lift components. Pay attention when moving the Crossbeams and Beams; they are extremely heavy, and if they fall, could cause serious injury.

To set up and install the Front Beam:

1. Place the Front Beam onto a heavy-duty rolling dolly and move it, on the ground, into location between the two Lift Posts at the Front of the Lift.

Make sure to orient the Front Beam correctly.

2. Bolt the Sheave Mount Assemblies in the correct locations on the Front Beam.

The following illustration shows the connections for the Four-Sheave Mount Assembly; the Two-Sheave Mount Assemblies use the same type of M16 hardware.

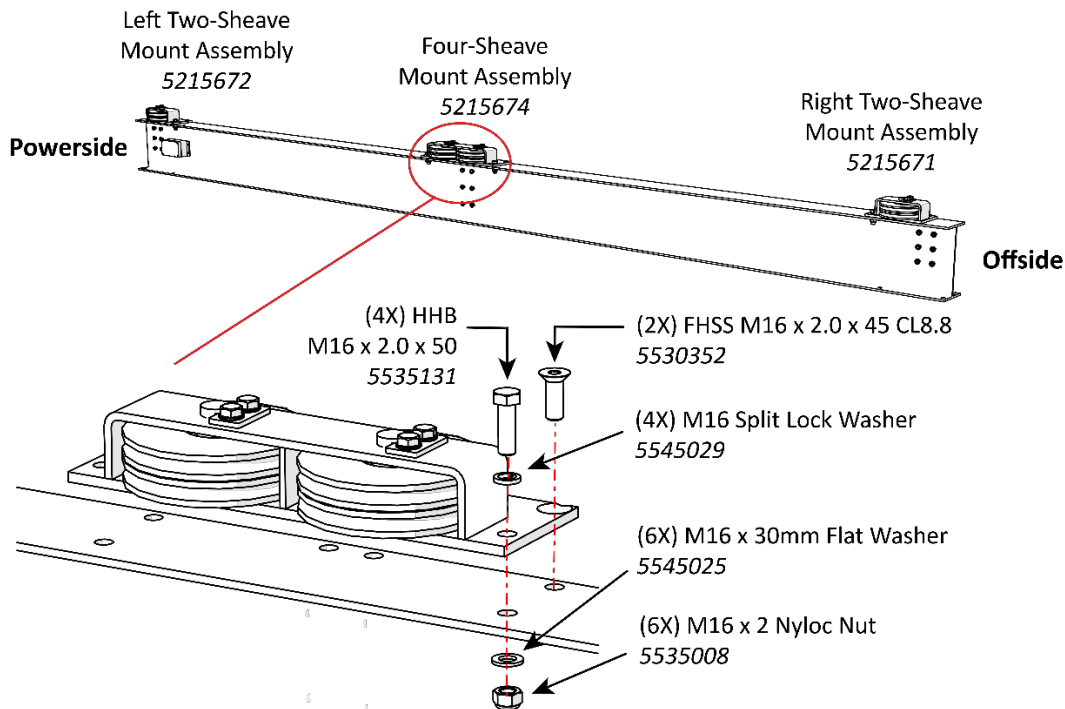

3. Using a Forklift or Shop Crane, carefully raise the Front Beam and bolt it in place on each end.

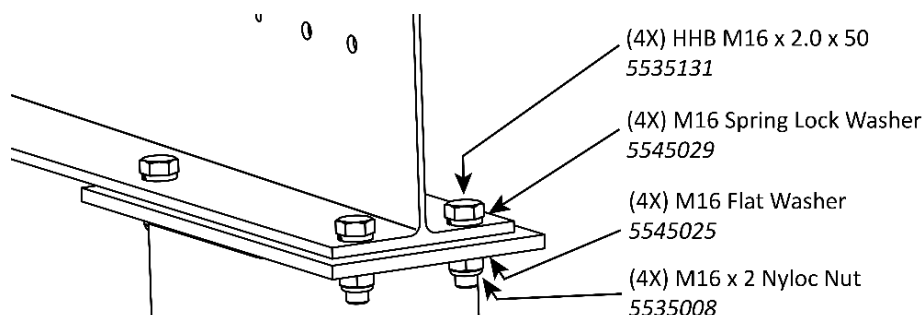

Install the Rear Beam

Install the Rear Beam after installing the Front Beam. There are no components that go on top of the Rear Beam; you simply need to raise it into position and put the Bolts in place.

Make sure the orientation is correct, the labels on the Rear Beam need to be facing out so they can be seen as Vehicles drive onto the Platforms.

⚠ WARNING You **must** use a proper lifting device such as a Forklift or Shop Crane to raise and position the Lift components. Pay close attention when moving the Crossbeams and Beams into position; they are extremely heavy and long, and could shift position or fall, potentially causing serious injury.

To install the Rear Beam:

1. Using a Forklift or Shop Crane, put the Rear Beam onto a heavy-duty rolling dolly and move it, on the ground, into location between the two Posts at the Rear of the Lift.

Make sure to orient the Rear Beam correctly.

2. Carefully raise the Rear Beam into position on top of the two Posts, then bolt it into place using the same type of M16 hardware used to secure the Front Beam (on previous page).

You need four M16 Hex Head Bolts (5535131), M16 Split Lock Washers (5545029), M16 Flat Washers (5545025), and M16 Nyloc Nuts (5535008).

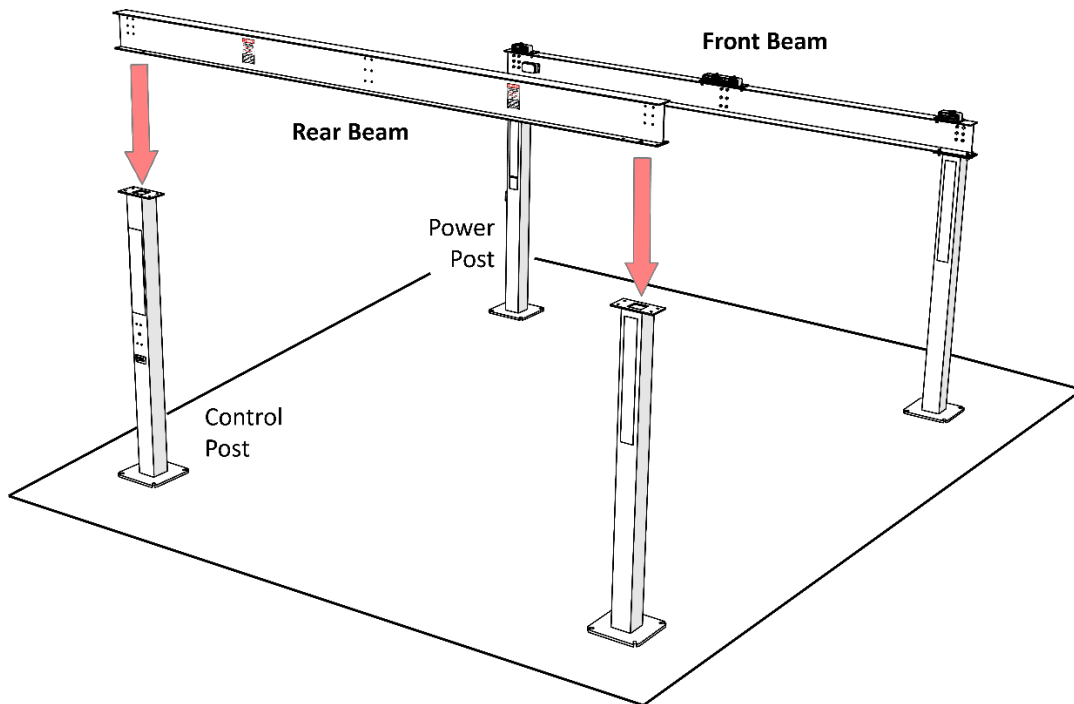

3. Do not torque the bolts at this point.

Prepare and Install the Offside Crossbeam

Crossbeams connect the Front Beam on one end and to the Rear Beam on the other end. Your Lift will have either three or four crossbeams:

- **PL-6KDT and PL-6KDTX.** Three Crossbeams: one Powerside, one Center, and one Offside.
- **PL-6KDW.** Four Crossbeams: one Powerside, two Center (only one has the Safety Latch Bar), and one Offside.
- **PL-6KT.** Four Crossbeams: one Powerside, **two Center**, and one Offside.

Before you can raise the Offside Crossbeam into place, you must prepare it by adding two Sheaves.

NOTICE: Similar to the Sheaves on the top of the Front Beam, the Sheaves in the Crossbeams do **not** come installed; you must remove the Sheave cover, put the Sheave in place, and then replace the cover. Also, they are installed on the side of the beam, not on the top.

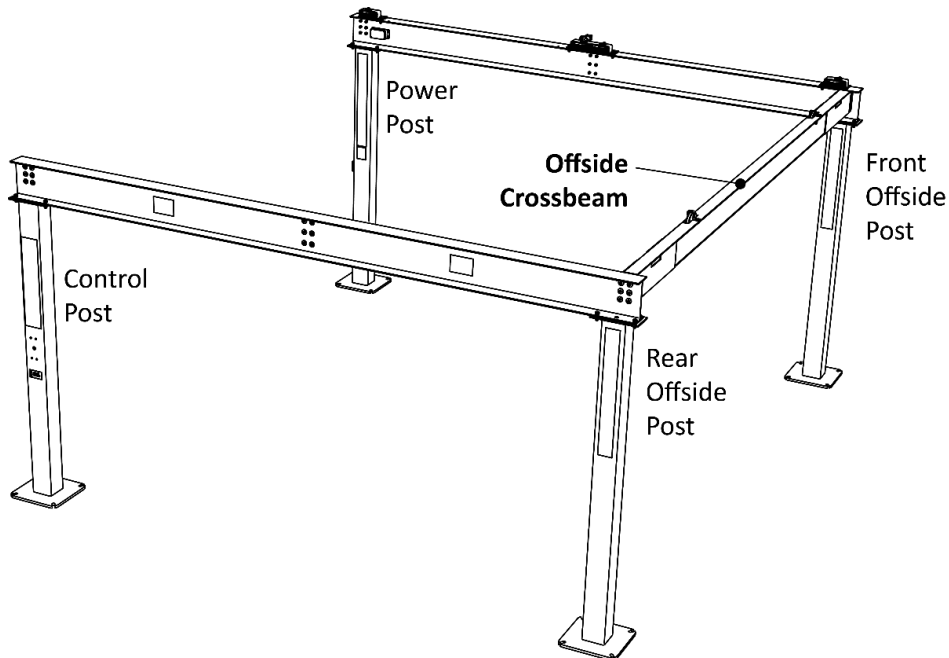

To prepare the Crossbeam Sheaves:

1. Using a Forklift or Crane, put the Offside Crossbeam onto a heavy-duty rolling dolly and move it, on the ground, into location between the Front Beam and the Rear Beam.

Make sure to orient the Offside Crossbeam correctly. The Sheaves must face the inside of the Lift.

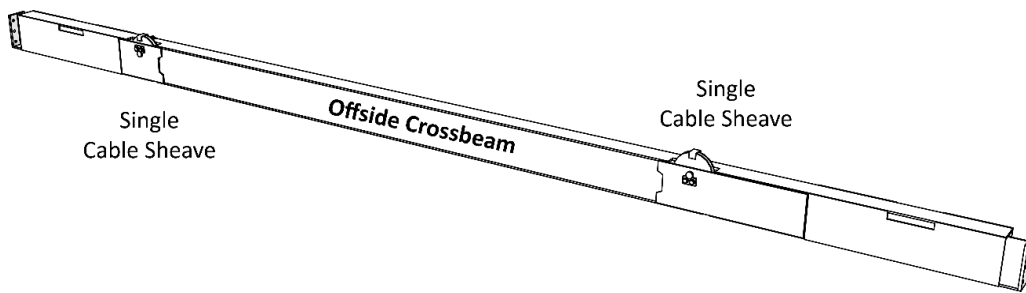

Note: The Sheave covers and Sheaves are **not** interchangeable; they are similar but not the same. Some appear higher than others; this is by design.

- Remove a Sheave cover, put a single Sheave into place, then replace the Sheave cover; do the same for the other Sheave on the Offside Crossbeam. **Lubricate all Sheave Bearings and Pins with Red Lithium Grease when assembling.**

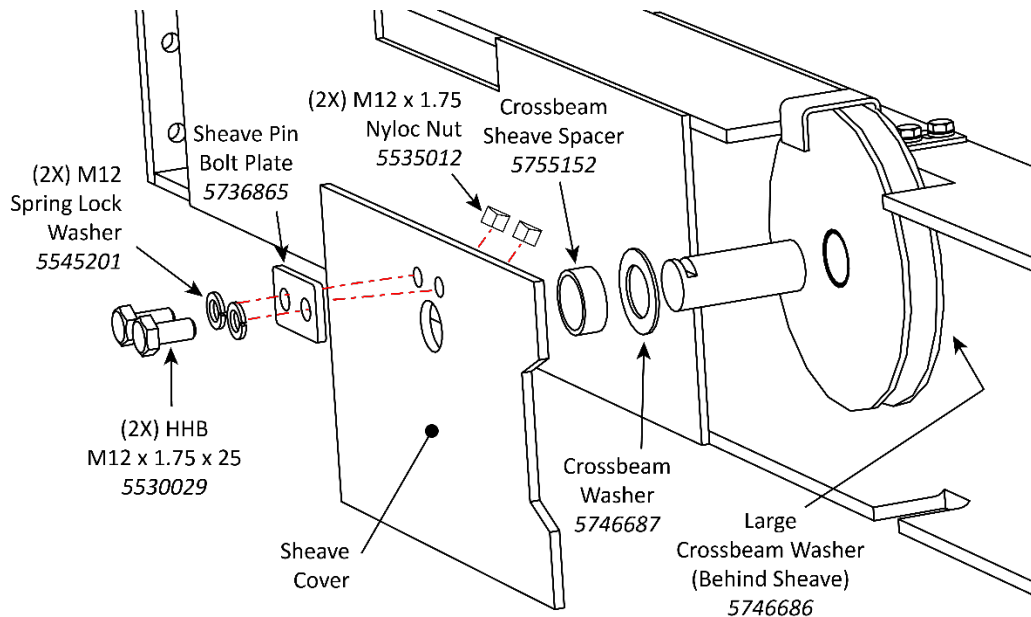

- When both Sheaves are installed, use a Forklift or Shop Crane to carefully raise the Offside Crossbeam into the space between the Front Beam and the Rear Beam.

⚠ WARNING You must use a proper lifting device such as a Forklift or Shop Crane to raise and position the Lift components. Pay close attention when moving the Crossbeams and Beams into position; they are extremely heavy and long, and could shift position or fall, potentially causing serious injury.

- Attach the Front end of the Offside Crossbeam to the Front Beam; put the Nuts and Bolts into position, **but do not torque them yet.**

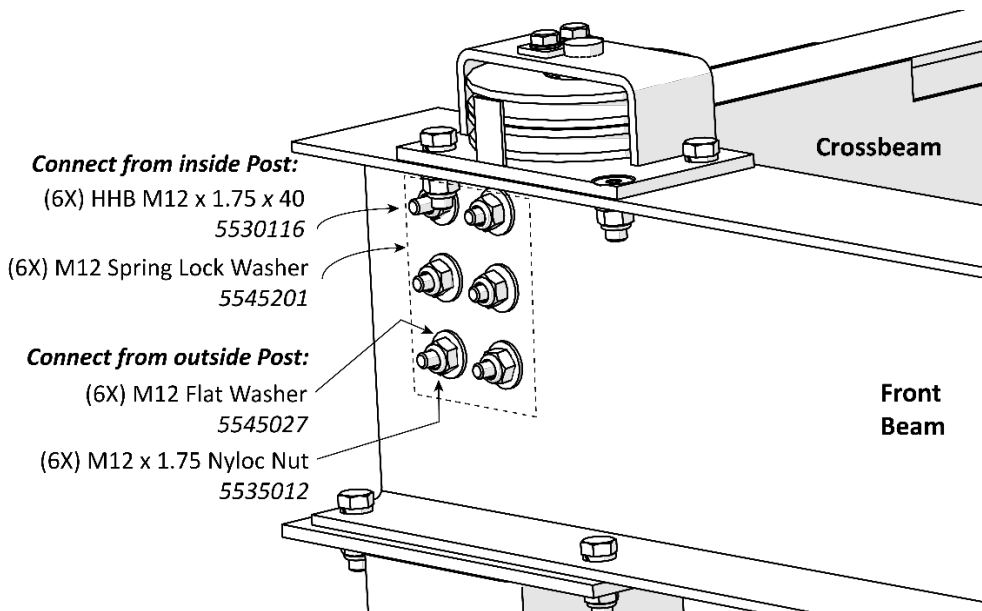

- Repeat Step 4 for attaching the Rear end of the Offside Crossbeam to the Rear Beam.

Prepare the Center Crossbeam(s)

The PL-6KDT and the PL-6KDTX each have one Center Crossbeam.

The PL-6KT has **two** Center Crossbeams, so you will be preparing and installing two Center Crossbeams. The process is the same for the second Center Crossbeam.

While the PL-6KDW also has two Center Crossbeams, only one has the Safety Latch Bar Assembly.

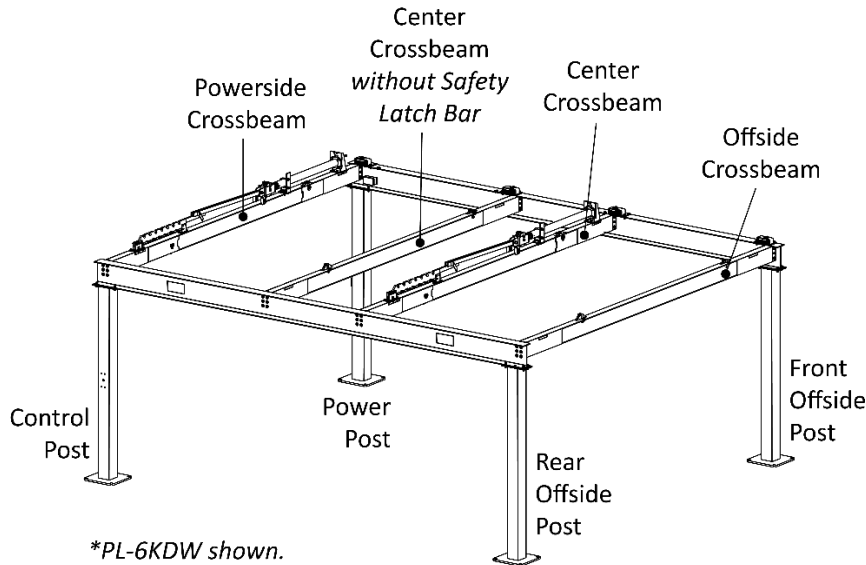

The following illustration shows the main components of the Center Crossbeam.

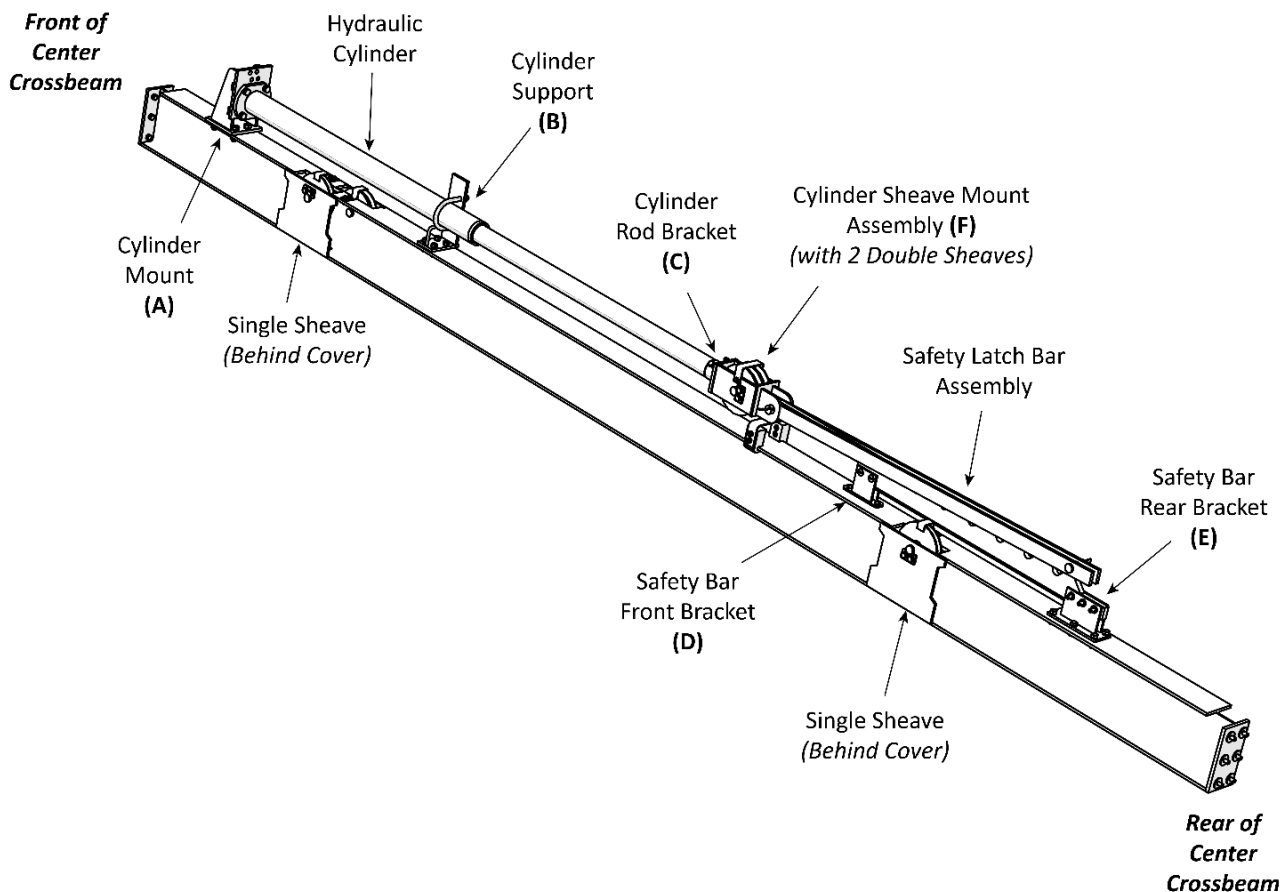

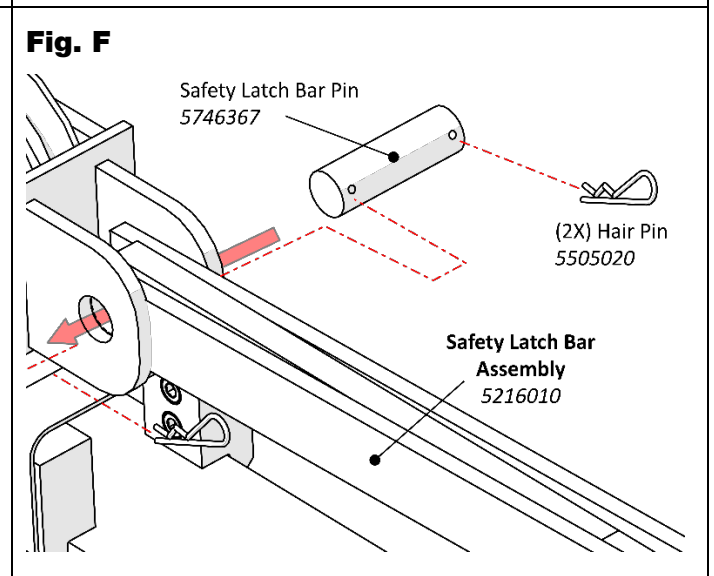
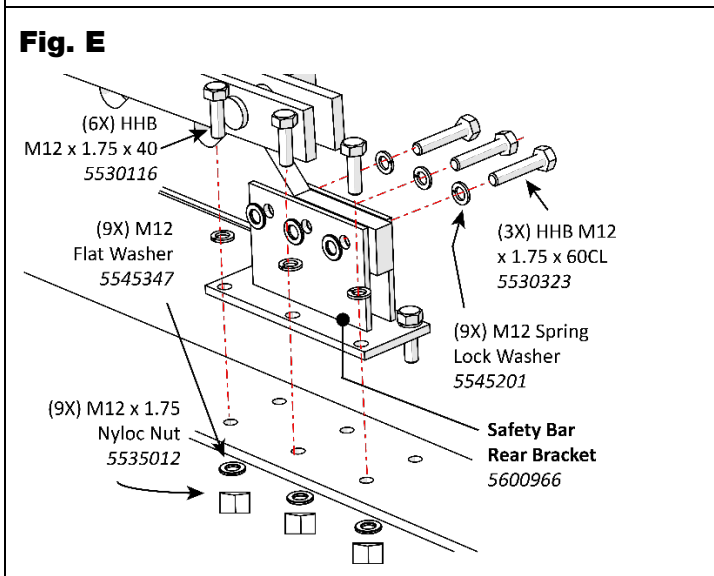
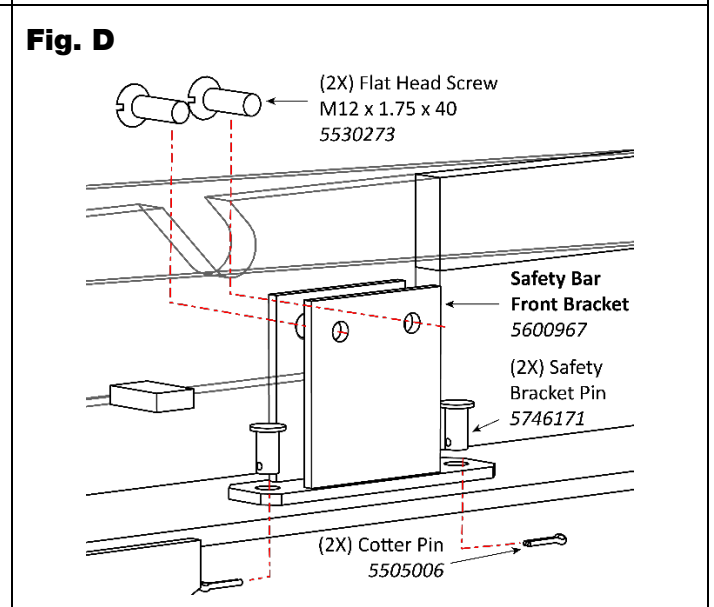
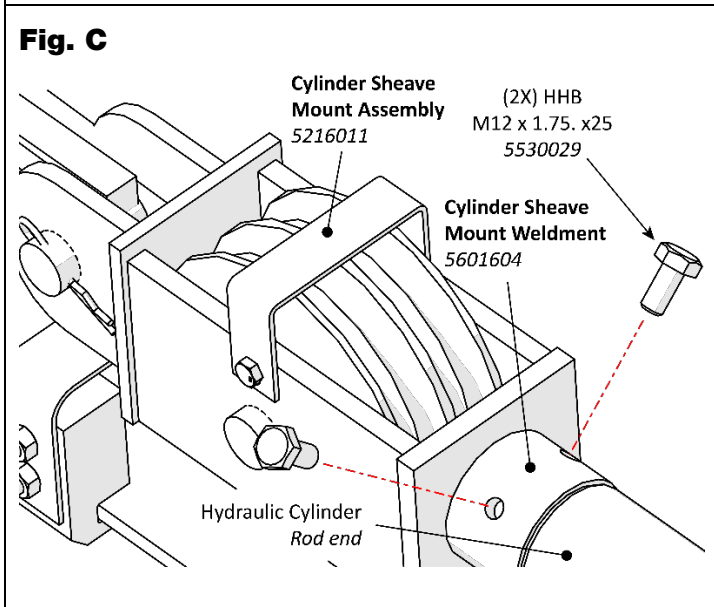
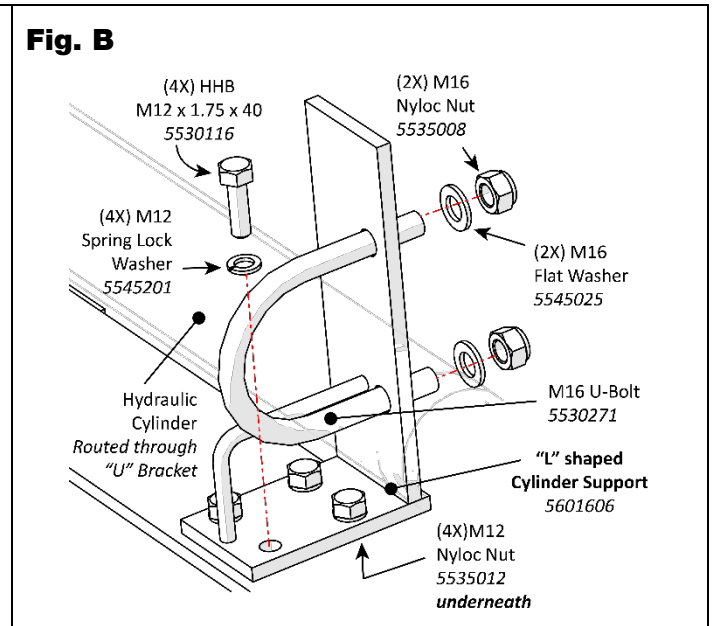
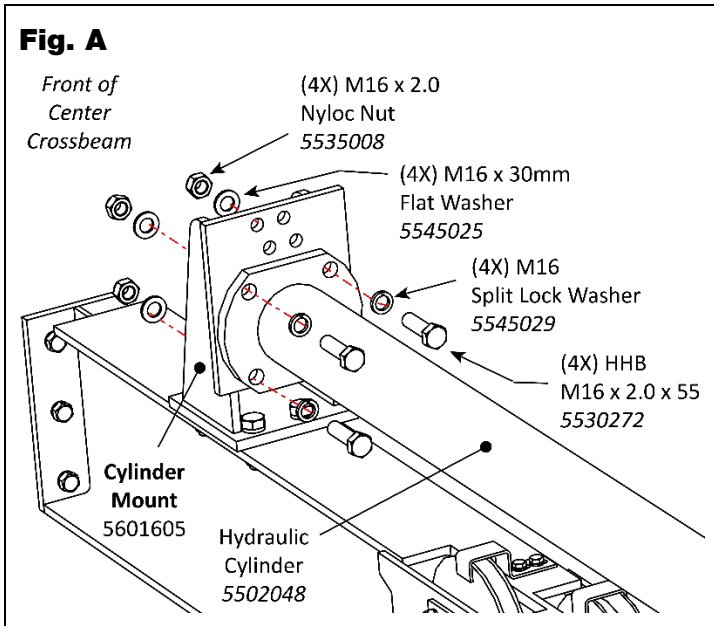

NOTICE Use the illustrations on the previous two pages in conjunction with this procedure.

To assemble the Center Crossbeam:

1. Using a Forklift or Shop Crane, put the Center Crossbeam onto a heavy-duty rolling dolly and move it, on the ground, into location between the Front Beam and the Rear Beam.

Make sure to orient the Center Crossbeam correctly.

2. Locate the Cylinder Mount, then secure it to the Center Crossbeam using four Hex Bolts.

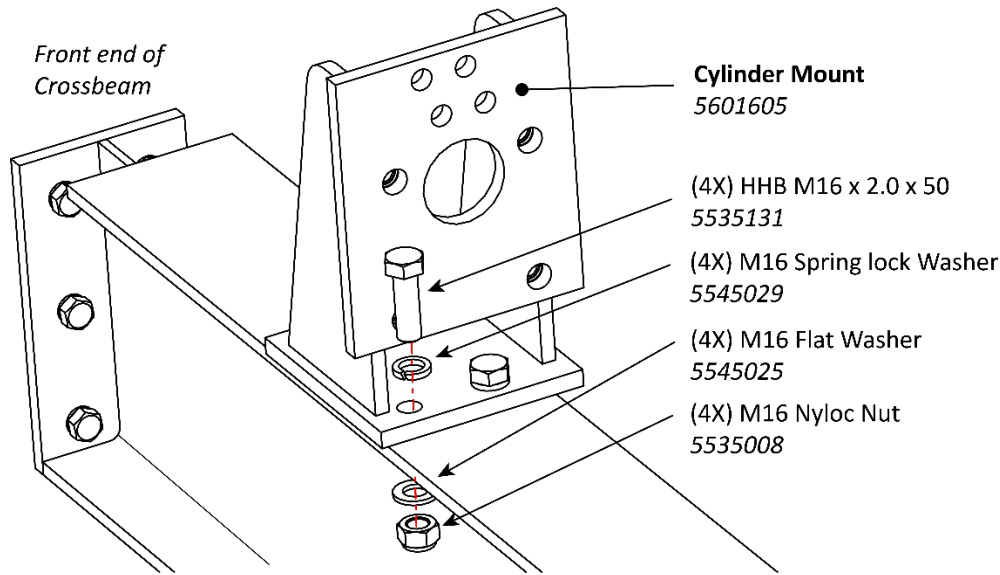

3. Locate the Cylinder Support, then secure it to the Center Crossbeam (**Fig. B**).
4. Locate the Cylinder Sheave Mount Assembly and move it into position.

NOTICE The Cylinder Sheave Mount Weldment does **not** get connected to the Center Crossbeam. Rather, it connects to the Cylinder Rod on one end and the Safety Latch on the other end.

5. Move the Hydraulic Cylinder into position, then connect it to the Cylinder Mount (**Fig. A**).
6. Rest the Hydraulic Cylinder on the Cylinder Support, then install the U-bolt bracket to hold it in place.
7. Connect the Cylinder Rod to the Cylinder Sheave Mount Weldment using two Hex Bolts (**Fig. C**).
8. Locate the Safety Latch Bar Assembly; the Safety Bar Front Bracket, the Safety Bar Rear Bracket, and the Safety Latch Trip Plate come assembled.
9. Attach the Safety Bar to the top of the Center Crossbeam (**Fig D.** and **Fig. E**).
10. Locate the Safety Latch Bar and attach one end to the circular end of the Cylinder Sheave Mount Weldment (**Fig. F**).

11. Install the Sheaves on the Center Crossbeam. There are five: three on the offside and two on the Powerside of the beam. **Lubricate all Sheave Bearings and Pins with Red Lithium Grease when assembling.**

The following illustration shows the Single Sheave near the front of the Center Crossbeam.

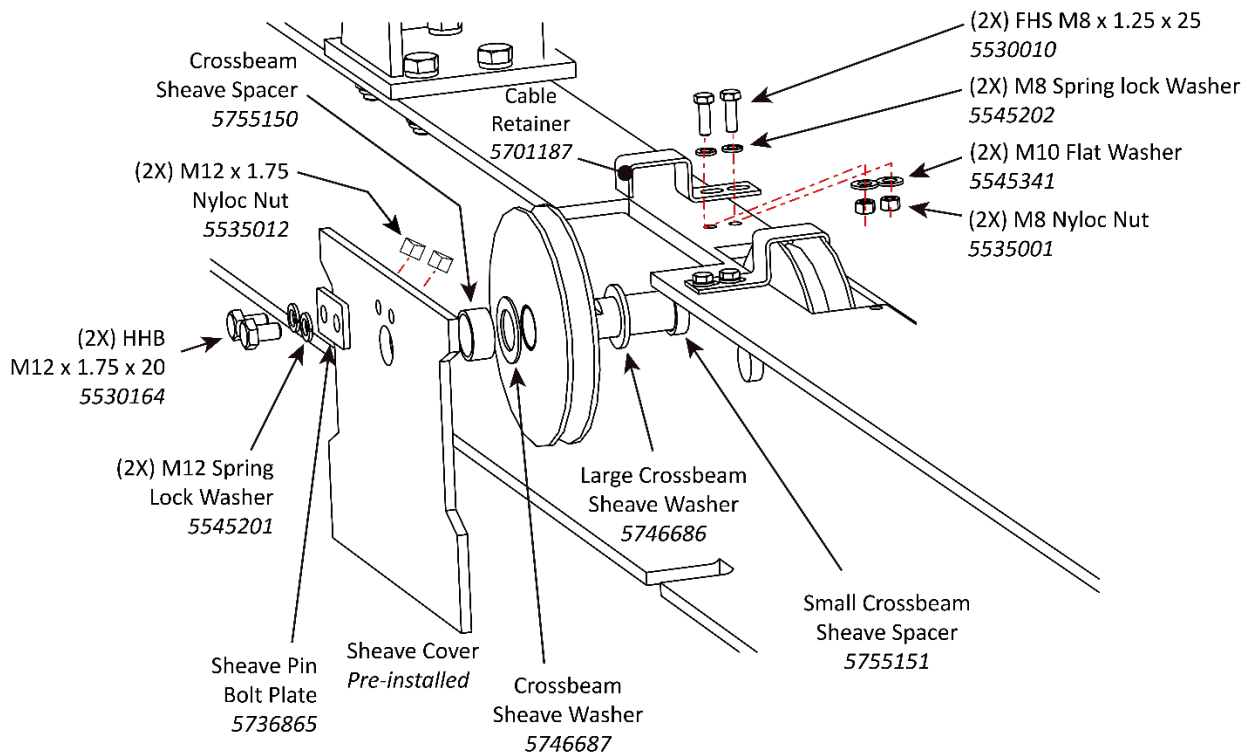

Drawing shows Sheave connection on Center Crossbeam. Hydraulic Cylinder removed for clarity.

Route the Cables on the Center Crossbeam(s)

This section describes how to route the Cables on the Center Crossbeam.

If you are installing a PL-6KD model, this Cabling is done once for the Offside Platform. If you are installing a PL-6KT, you will be performing this procedure twice: once for the Offside Platform and once for the Center Platform.

Note: If you are installing and raising each Beam separately, you cannot finish routing the Center Crossbeam Cables until after the Beam is raised into position.

The following illustration shows **all four Cable routes** in one drawing.

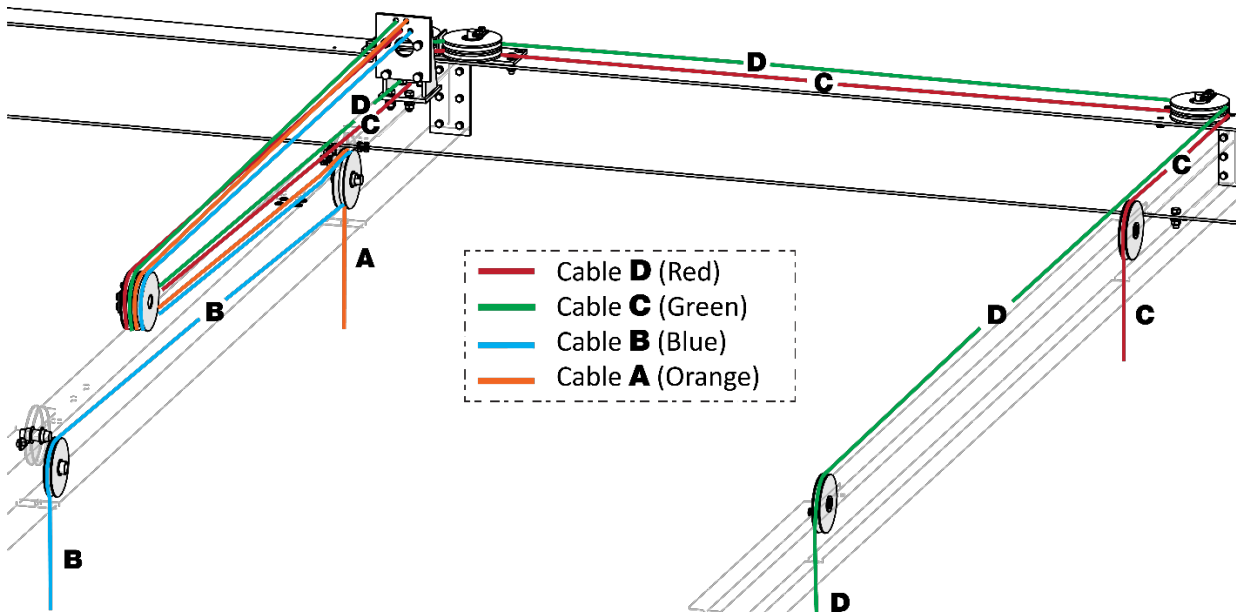

Some components are not shown or have been moved slightly to enhance understanding.

NOTICE

All Cables have varying lengths and can only make one connection; if they are routed to the wrong locations, they will either be too short or too long.

CAUTION

BendPak strongly recommends wearing gloves specifically designed for Cable handling while you are routing the Cables. If the Cables fray, they are much more difficult to route and more likely to cut your hands.

In the following drawings, the Cables are labeled A, B, C, and D. These letters are **not** on the label attached the Cable. You have to match the Cable letter with the length:

- **D:** 50 feet / 15,324 mm. Part Number 5595687.
- **C:** 40.5 feet / 12,260 mm. Part Number 5595686.
- **B:** 35 feet / 10,544 mm. Part Number 5595685.
- **A:** 25 feet / 7,542 mm. Parts Number 5595637.

To route the Cables on a Center Crossbeam:

1. Make sure you have nearby the four Lifting Cables, then insert the Button Ends of the Lifting Cables in their **required** locations in the Cable Lock Plate.

See the illustration on the following page for a detailed view of the Cable Lock Plate.

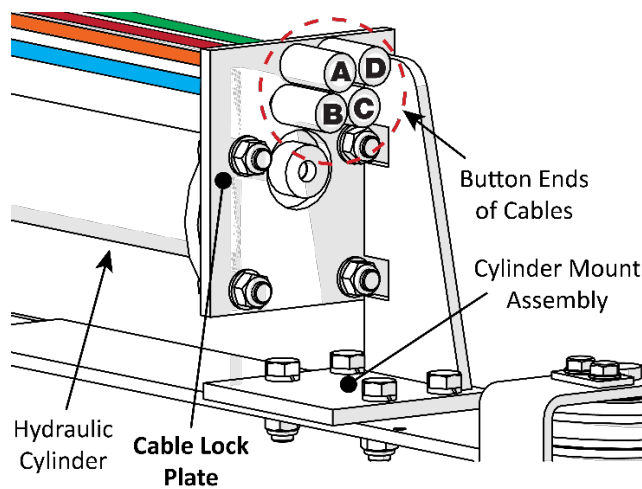

Drawing is a front view of the Cable Lock Plate (attached to the Cylinder Mount), looking from the Rear Beam towards the Front Beam.

Cables are pushed in from the non-cylinder side of the Lock Plate.

2. With the Button ends of the Cables secure in the Cable Lock Plate, route the non-button ends of the Cables to their **required** locations in the Cylinder Sheave Mount Assembly, going first over the top of the Sheave and then under the Sheave, heading back towards the Cylinder Mount.
3. For Cables **A** and **B**, before getting to the Cylinder Mount, route them to the Double Sheave on the Offside Platform side of the Center Crossbeam:
 - Route Cable **A** over the Sheave **closest** to the Center Crossbeam and then down.
 - Route Cable **B** over the Sheave **furthest** from the Center Crossbeam and then over to the single Sheave near the Rear Beam.

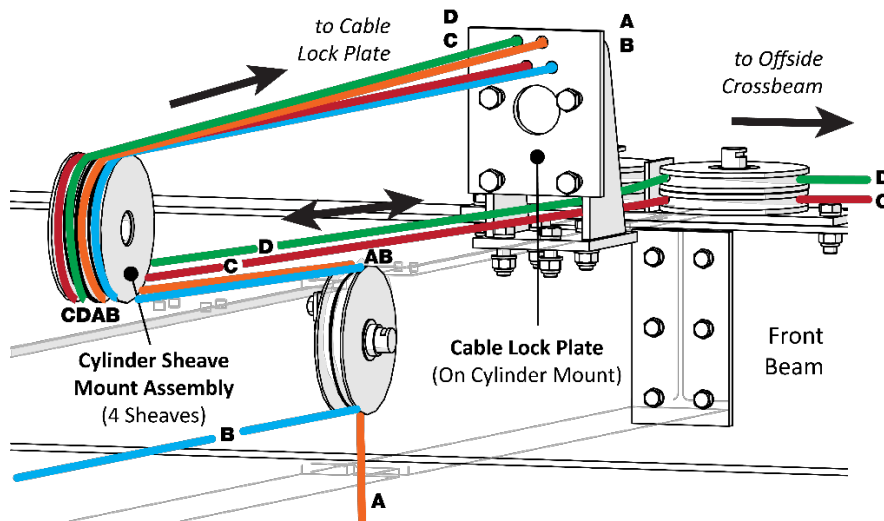

4. Pull Cables **A** and **B** as far as you can towards their destinations and then put them off to the side. You cannot do anything more with them until you have the Offside Platform structure assembled.
5. For Cables **C** and **D**, route them through the open area at the bottom of the Cylinder Mount.
 - If you are installing and raising each beam separately, put Cables **C** and **D** off to the side; you cannot route them any further until the Center Crossbeam is raised into position.
 - If you are installing and raising all of the beams at the same time, route Cables **C** and **D** first through the Double Sheave on the Front Beam next to the Cylinder Mount, then through the Double Sheave near the Offside Crossbeam, then to the appropriate Sheaves on the Offside Crossbeam, then down. After that, put them off to the side, as you cannot do anything else with them until you have the Offside Platform structure assembled.

Raise the Center Crossbeam(s) into Position

This procedure assumes the Center Crossbeam has all components in place, including as much Cable routing as can be done to this point.

The following illustration shows the correct location for the Center Crossbeam.

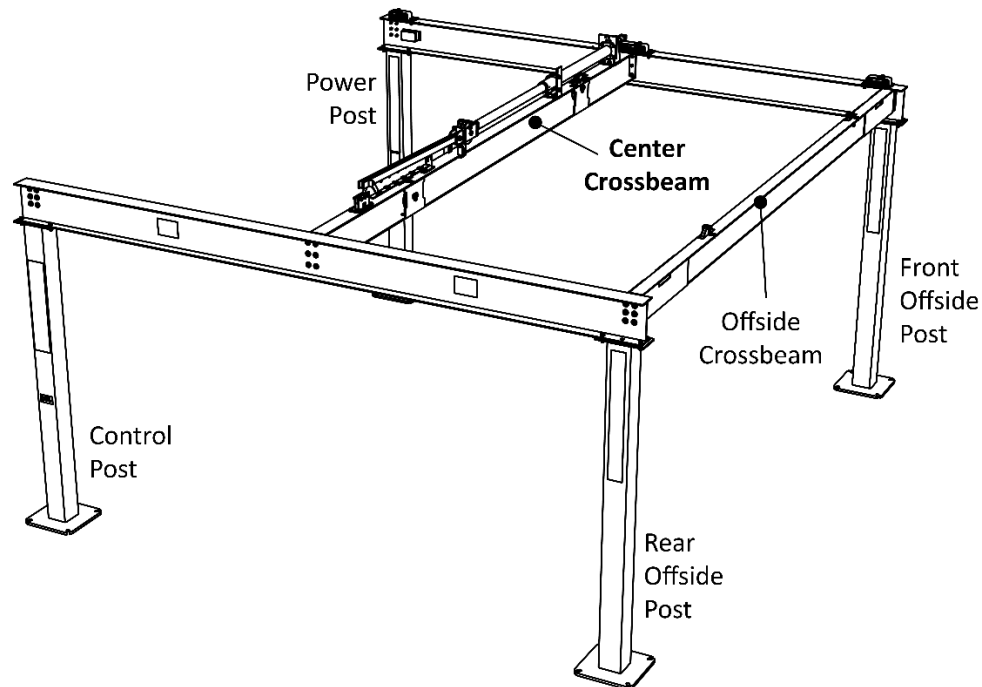

⚠ WARNING You must use a proper lifting device such as a Forklift or Shop Crane to raise and position the Lift components. Pay close attention when moving the Lift components into position; they are extremely heavy and long, and could shift position or fall, potentially causing serious injury.

To raise the Center Crossbeam(s) into position and secure it:

1. Using a proper lifting device, carefully raise the Center Crossbeam into the space between the Front Beam and the Rear Beam.
2. Attach the **front end** of the Center Crossbeam to the **Front Beam**; put the Nuts and Bolts into position, but do not torque them yet.

Do the same for connecting the **rear end** of the Center Crossbeam to the **Rear Beam**.

3. Route Cables **C** and **D** through the Double Sheaves on the Front Beam and then through the Single Sheaves on the Offside Crossbeam (or the other Center Crossbeam, if you are working on the second Center Crossbeam on a PL-6KT).

NOTICE There are two sets of Double Sheaves on the Front Beam next to the Cylinder Mount. Do not use the Double Sheaves on the left; instead, use the Double Sheaves on the right, closest to the Offside Platform.

4. Secure the Cables that are hanging down; you will not need to use them again until the Platform structures are assembled.
5. Torque the Bolts that hold the Center Crossbeam to the Front Beam and the Rear Beam.

Torque the Bolts to 45-50 ft.-lbf.

Prepare the Powerside Crossbeam

The components on the top of the Powerside Crossbeam are exactly the same as the components on the top of the Center Crossbeam(s).

Because they are exactly the same, simply repeat the same process for the Powerside Crossbeam as you performed for the Center Crossbeam(s).

There are a couple of small differences in the Powerside Crossbeam itself, so it is shown below, but those differences involve the Sheaves and have no impact on this part of the installation.

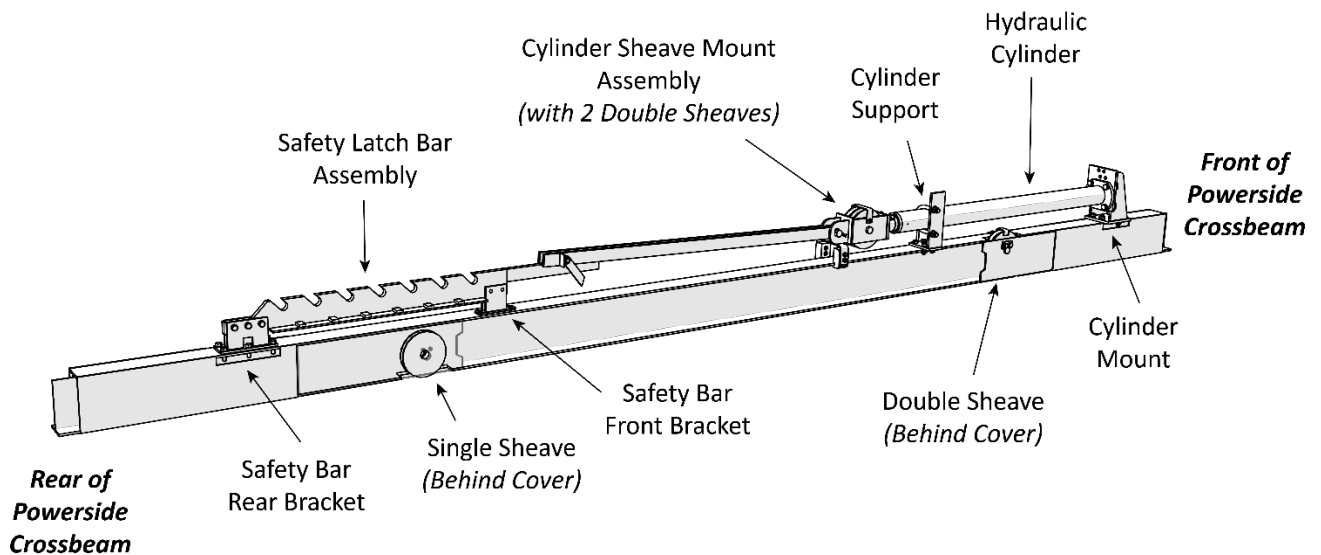

Routing the Cables on the Powerside Crossbeam

Routing the Cables on the Powerside Crossbeam is almost exactly the same as routing the Cables on the Center Crossbeam(s); the Sheave locations on the Front Beam are the only differences.

Because they are almost exactly the same, simply repeat the same process for the Powerside Crossbeam as you performed for the Center Crossbeam(s), noting the slightly different Sheave locations shown above.

Raise the Powerside Crossbeam into Position

This procedure assumes the Powerside Crossbeam has all components in place, including as much Cable routing as can be done to this point.

The following illustration shows how to arrange the Powerside Crossbeam on the Lift.

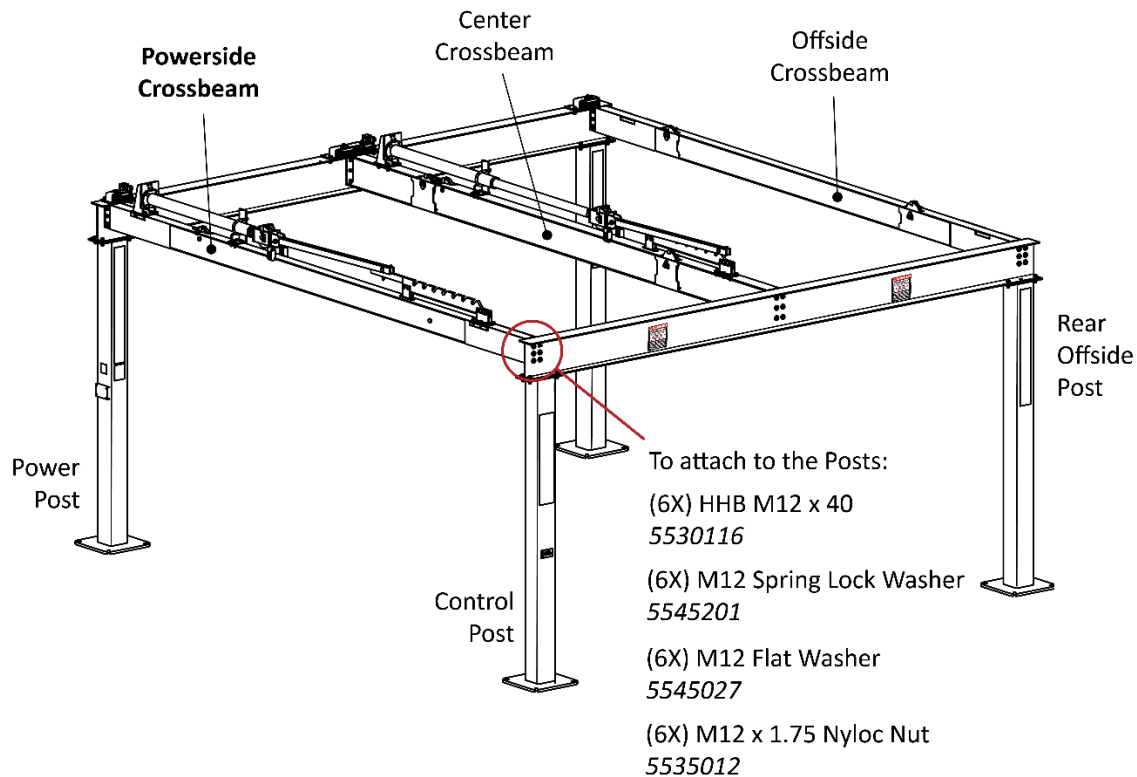

⚠ WARNING You **must** use a proper lifting device such as a Forklift or Shop Crane to raise and position the Lift components. Pay close attention when moving the Lift components into position; they are extremely heavy and long, and could shift position or fall, potentially causing serious injury.

To raise the Powerside Crossbeam into position and secure it:

1. Using a Forklift or Shop Crane, carefully raise the Powerside Crossbeam into the space between the Front Beam and the Rear Beam.
2. Attach the **front end** of the Powerside Crossbeam to the **Front Beam**; put the Nuts and Bolts into position, but do not torque them yet.
Do the same for the attaching the **rear end** of the Powerside Crossbeam to the **Rear Beam**.
3. Route Cables **A** and **B** through their respective Sheaves on the Powerside Crossbeam.
4. Route Cables **C** and **D** through the Double Sheave Assembly on the Front Beam and then through the Single Sheaves on the Center Crossbeam.
5. Secure the four Cables that are hanging down; you will not need to use them again until the Platform structures are assembled.
6. Torque the bolts that hold the Center Crossbeam to the Front Beam and the Rear Beam; torque to 45-50 ft.-lbf.

Install the Power Unit

This section describes how to install, but not connect, the Power Unit for your Lift. An Electrician is **not** required to mount the Power Unit to the Power Post.

The Power Unit **must** be installed on the Power Post, attached to the Mount Plate.

⚠ DANGER **Risk of explosion:** This equipment has internal arcing or parts that may spark and should not be exposed to flammable vapors. Never expose the motor to rain or other damp environments. Damage to the motor caused by water is not covered by the warranty.

The Power Unit's Hydraulic Fluid reservoir must be filled with Hydraulic Fluid or automatic transmission fluid before you begin operation of the Lift. **When you receive the Lift, the oil reservoir is empty.** The Power Unit will not work correctly until it is filled with approved Hydraulic Fluid.

Approved Hydraulic Fluids include any general purpose ISO-32, ISO-46, or ISO-68 hydraulic oil, automatic transmission fluids, such as Dexron® III and VI; Mercon® V and LV; Tellus S2 / S3 / S4, or synthetic multi-vehicle automatic transmission fluid.

⚠ WARNING Do not run your Power Unit without Hydraulic Fluid; you will damage it. Keep the Power Unit dry; damage to the Power Unit caused by water, detergents, acid, and other liquids is **not** covered by the warranty.

To install the Power Unit:

1. Find the four supplied nuts and bolts.
2. Line up the holes on the Power Unit Back Plate with the four holes in the Power Post Mount Plate.

There are multiple locations on the Power Unit Back Plate you can use to attach to the Mount Plate. Choose the ones that best center the Power Unit on the Mount Plate.

⚠ CAUTION The Power Unit is heavy. BendPak strongly recommends having one person hold the Power Unit in place while another person bolts it into place.

3. Connect the Power Unit to the Power Post using the four nuts and bolts.
4. Fill the Hydraulic Reservoir on the Power Unit with approved fluids.

The Hydraulic Reservoir holds approximately **3.7 gallons (14 liters)**. Use care to keep the fluid clean when filling the reservoir.

Do not connect the Power Unit to a power source at this point.



IMPORTANT! PLEASE READ NOW



Hydraulic Fluid Contamination poses a serious issue for your Lift, contaminants such as water, dirt, or other debris can get into the Hydraulic Hoses and Fittings on the Lift, making your new Lift inoperable and unusable.

Your Lift is shipped with clean components; however, BendPak strongly recommends that you take secondary precautions and clean all Hydraulic Hoses and Fittings prior to making connections. It is better and less costly to take these extra steps now so that you do not need to take your Lift out of service later to fix issues that could have been prevented at the time of installation.

There are several ways to clean Hydraulic Hoses and Fittings:

- **Compressed Air.** Use an air compressor to blow out contaminants from each Hydraulic Hose and Fitting prior to installation. Clean, dry air is preferred. Wear ANSI-approved eye protection (safety glasses, goggles, or face shield) when using compressed air for cleaning. Never point an air hose nozzle at any part of your body or any other person.
- **Fluid Flushing.** As long as the Hydraulic Fluid is clean and compatible with the system fluid, you can flush Hoses and Fittings to create turbulent flow and remove particulates. Always ensure that the fluid itself is contaminant-free.

Some additional steps that will help keep the Hydraulic Fluid clean:

- **Remove old thread seal tape.** Some ports on the Hydraulic Cylinders are shipped with temporary plugs secured with thread seal tape, so make sure to thoroughly remove any leftover thread seal tape that may inadvertently enter the Hydraulic System.
- **Use a liquid thread sealant only.** Liquid thread sealant (Loctite™ 5452 or similar) is recommended. Do not use thread seal tape on any fitting. Liquid thread sealant is recommended for NPT connections, fine for JIC connections, but *not* necessary for O-ring (ORB) connections.
- **Always use clean equipment.** If you use a dirty bucket or funnel to transfer the Hydraulic Fluid into the Hydraulic Fluid Reservoir, the contaminants will likely be introduced into the Fluid. When using cleaning rags, use a lint-free rag.
- **Proper storage.** Keep the Hydraulic Fluid sealed in its container until ready for use; store the Fluid in a clean, dry, and cool area.
- **Cover the Hoses and Fittings.** Before installation, do not leave the ends of the Fittings exposed; the same applies for the Hydraulic Hoses. As a general rule, keep the Hydraulic Hoses and Fittings capped and in a clean area until ready for use.
- **Filter the new Hydraulic Fluid.** Just because it is new does not necessarily mean it is *clean*. Use an offline filtration cart or kidney loop system to make sure the Hydraulic Fluid is clean before being transferred into the Hydraulic Fluid Reservoir (even using a heavy duty nylon mesh screen is better than trusting what is left at the bottom of the barrel).
- **Avoid mixing different types of Hydraulic Fluid.** If Hydraulic Fluid needs to be replaced, make sure to flush the Hydraulic System of the old Hydraulic Fluid before you add the replacement Fluid; do not mix the two together.

About Thread Sealants

Liquid Thread Sealant lubricates and fills the gaps between the Fitting threads, and leaves no residue that could contaminate the Hydraulic Fluid.

Other types of Thread Sealants (like Teflon Tape) can shred during installation or removal and eventually enter the Hydraulic System.

Thread Sealant can be used with most Hydraulic Fittings, although you probably only need to use with NPT connectors.



To apply Thread Sealant:

1. Make sure the Fittings and connectors you are going to use are clean and dry.

If you are adding Thread Sealant to a Fitting or connector that has already been used with a different sealant, use a wire brush to thoroughly remove the old sealant before adding more.

2. Apply a small amount of Thread Sealant to the first four threads of the Fitting.

⚠ WARNING Always wear the proper protective equipment when handling Thread Sealant.

You only need a small amount because the sealant spreads to the other threads as it is tightened into place.

If you put too much, the excess liquid will be pushed out when the Fitting is tightened; use a rag to wipe the excess.

3. Tighten the Fitting into the connector; do **not** over tighten the Fitting.
4. Allow the **24 hour** manufacturer-recommended curing time before pressurizing the system.

Install and Connect the Hydraulic System

The Hydraulic System moves hydraulic force from the Power Unit to the Hydraulic Cylinders, which use that force to raise and lower the Platforms.

The Hydraulic System includes:

- **A Power Unit.** Creates the hydraulic force that needs to be moved to the Hydraulic Cylinders.
- **One Short Hydraulic Hose.** Connects the Power Unit to a Tee fitting at the closest Hydraulic Cylinder.
- **One or two Long Hydraulic Hoses.** For the PL-6KD models, there is one Long Hydraulic Hose. It connects the first Hydraulic Cylinder to the furthest (and last) Hydraulic Cylinder.

For the PL-6KT model, there are two Long Hydraulic Hoses. One connects the first Hydraulic Cylinder to the second Hydraulic Cylinder; the second connects the second Hydraulic Cylinder to the furthest (and last) Hydraulic Cylinder.

- **Two or three Solenoid Valve Block Assemblies.** One per Hydraulic Cylinder. The Assembly includes a Solenoid to control which Platform is the active Platform.

The following drawing shows the major components of the PL-6K Series Hydraulic System.

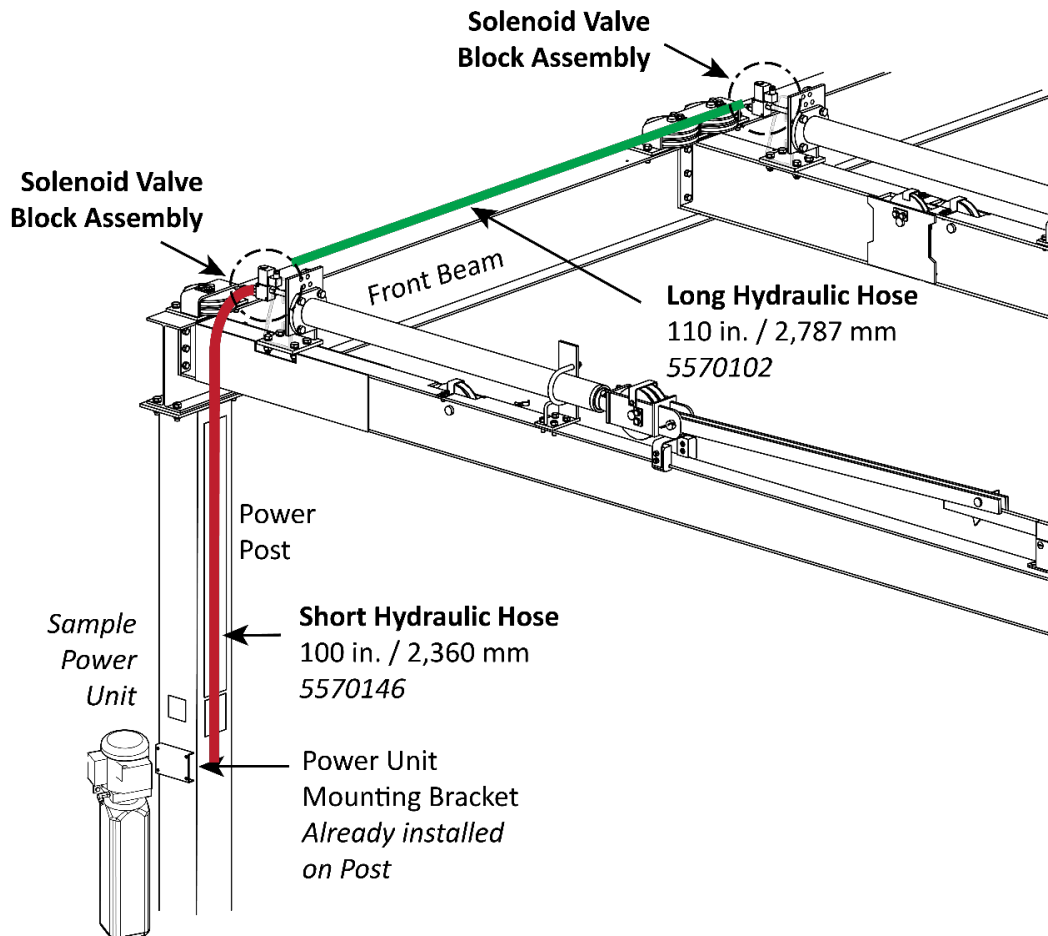

Drawing not to scale. Not all components shown. Includes both top and side views. A detailed drawing of the Solenoid Valve Block Assembly is shown on the next page.

To connect the Hydraulic System:

1. Prepare two or three Solenoid Valve Block Assemblies, depending on what model you are installing; connect one to each Hydraulic Cylinder just above the Front Beam.

Use Thread Sealant on NPT Threads only.

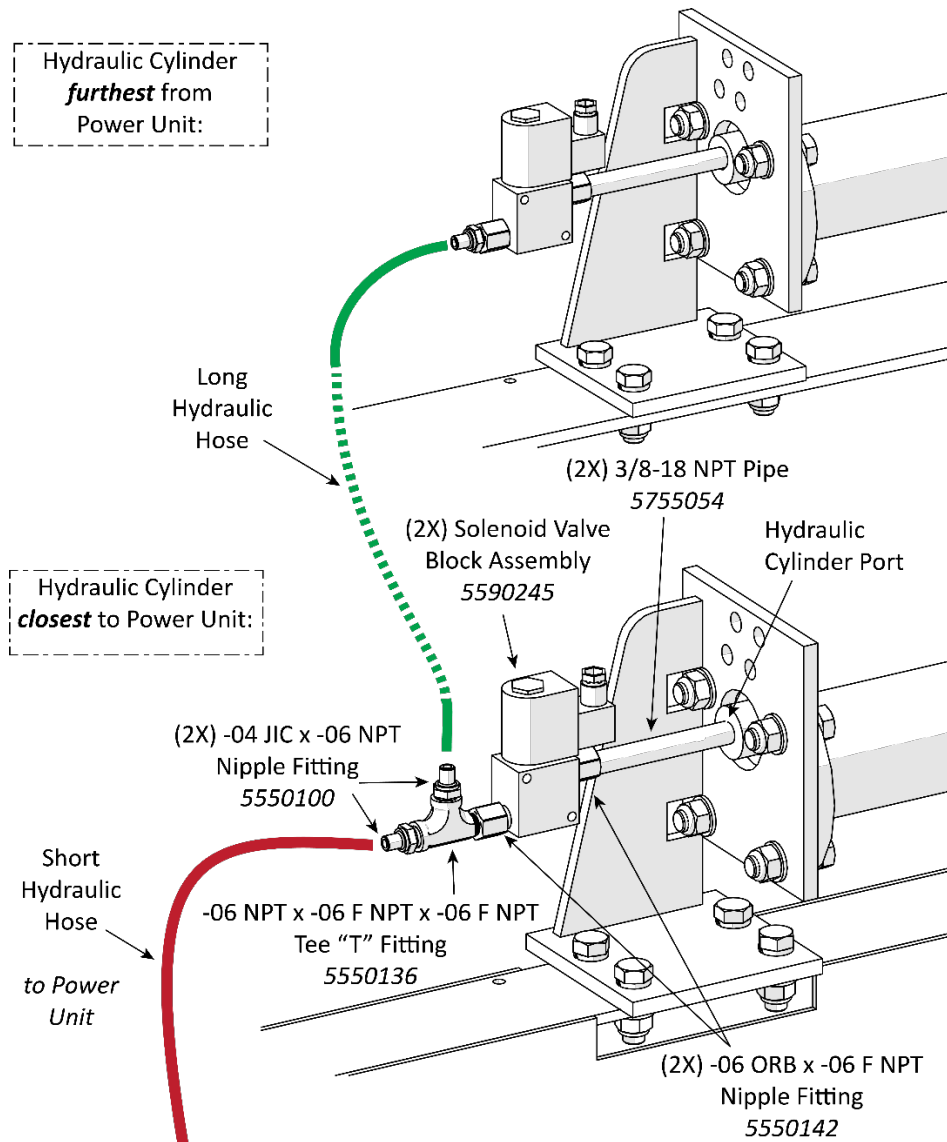

2. Connect the Short Hydraulic Hose to the Hydraulic Out Port on the Power Unit on one end and to the Tee Fitting on the closest Solenoid Valve Block Assembly.
Hydraulic Out Ports are commonly labelled **P1/P2** on the Power Unit. There is a drawing of the Power Unit that shows the Hydraulic Out Ports in **Connect the Power Source**.
3. Connect a Long Hydraulic Hose between the Tee fitting on the closest Solenoid Valve Block Assembly to either the Fitting on the last Solenoid Valve Block Assembly (for Models PL-6KDT and PL-6KDW) or to the Tee fitting on the next Solenoid Valve Block Assembly (for Model PL-6KT).
4. **Model PL-6KT only:** Connect the second Long Hydraulic Hose to the final Solenoid Valve Block Assembly.
5. Securely tighten all connections.

Contact the Electrician

As mentioned previously, there are four installation tasks that **require** a licensed, certified Electrician.

⚠ DANGER All wiring **must** be performed by a licensed, certified Electrician in accordance with all applicable local, state and national electrical codes.

All installations need an Electrician to:

- **Connect a 220 VAC power source to the Power Unit.** A power source is required. Refer to **Connect the Power Source** for more information.
- **Install a Power Disconnect Switch.** Ensures you can quickly and completely interrupt electrical power to the Lift in the event of an electrical circuit fault, emergency situation, or when equipment is undergoing service or maintenance. You must put it within sight and easy reach of the Lift operator. Refer to **Install a Power Disconnect Switch** for more information.
- **Install a Thermal Disconnect Switch.** Ensures the equipment shuts down in the event of an overload or an overheated motor. Refer to **Install a Thermal Disconnect Switch** for more information.
- **Connect the Controls.** The Controls are used to raise and lower the Platforms. The Controls must be wired appropriately; refer to **Connect the Controls** for more information.

These installation tasks are described in detail in the following four sections.

The Electrician is responsible for providing:

- an appropriate wiring and conduit to protect and connect to the power source
- a Power Disconnect Switch
- a Thermal Disconnect Switch
- wiring for the Lift Controls

NOTICE All wiring for the Controls must be minimum of #16 AWG (note that local codes may require heavier gauge). BendPak recommends encasing all wiring to protect it from the damage and securing it from movement.

The wiring for the Controls requires:

- **Control Box to Junction Box:** 5 or 6 wires, depending on model. PL-6KD models require 5 wires, PL-6KT requires 6 wires. The wires are: one per button (Key, Up, Down) and one wire per Platform.
- **Power Unit to Junction Box:** 3 or 4 wires, depending on the Power Unit; see **Wiring Diagrams** and the drawing on the previous page for details.

Refer to **Wiring Diagrams** for additional wiring information.

Additional information is supplied in the section describing these tasks.

Connect the Power Source

The Power Unit must be connected to an appropriate power source.

The standard Power Unit for your Lift is 220 VAC, 50/60 Hz, single phase 4 H.P., 2880/3450 rpm.

Refer to [Wiring Diagrams](#) for wiring information.

⚠ DANGER All wiring **must** be performed by a licensed, certified Electrician in accordance with local, state and national electrical codes. Do not perform **any** maintenance or installation on the Lift without first making sure that main electrical power has been disconnected from the Lift and cannot be re-energized until all procedures are complete.

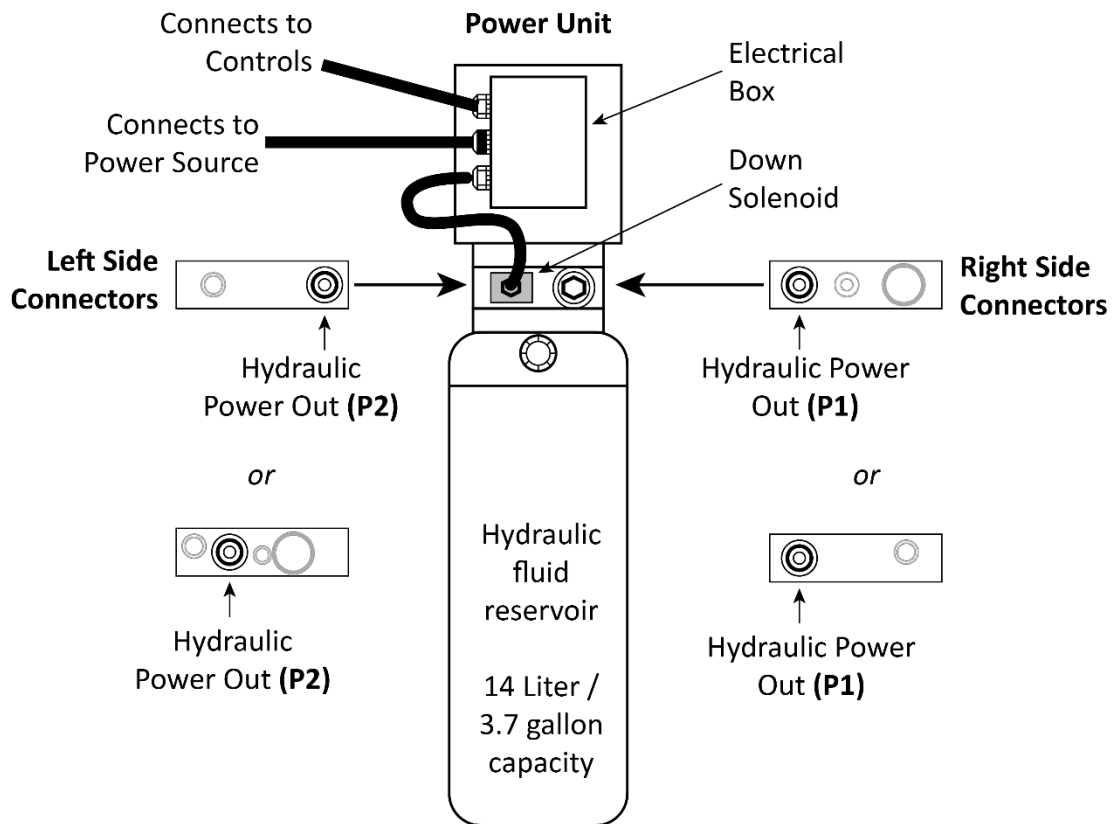

Important electrical information:

- Improper electrical installation can damage the Power Unit motor; this damage is not covered by the warranty.
- Use a separate circuit breaker for each Power Unit.
- Protect each circuit with a time-delay fuse or circuit breaker. For a 220 VAC, single phase circuit, use a 25 amp or greater fuse.
- As you require an Electrician on site to connect the Power Unit to a power source, you might also want to have them install the Power Disconnect Switch, Thermal Disconnect Switch, and the Controls on the same visit.

Connect the Controls

The Controls allow the operator of the Lift to select the desired Platform and then raise and lower it. Refer to [Wiring Diagrams](#) and the drawing on the next page for additional wiring information.

⚠ DANGER All wiring **must** be performed by a licensed, certified Electrician in accordance with all local, state, and national electrical codes.

The PL-6K Series Lift Controls include:

- **Control Box.** Houses the Controls that raise and lower Platforms. Installs on the Control Post. Connects to the Junction Box on the Front Beam.
- **Power Unit.** Provides power to the controls. Makes connections to the Junction Box.
- **Junction Box.** Connects the various pieces of the Controls together.
- **Solenoid Valve Assembly.** One per Hydraulic Cylinder. Solenoids control when hydraulic force goes to a particular Hydraulic Cylinder.

Refer to [Using the Control Box](#) for more information about how to use the Controls on the Control Box to raise and lower the Platforms of the PL-6K Series Lift.

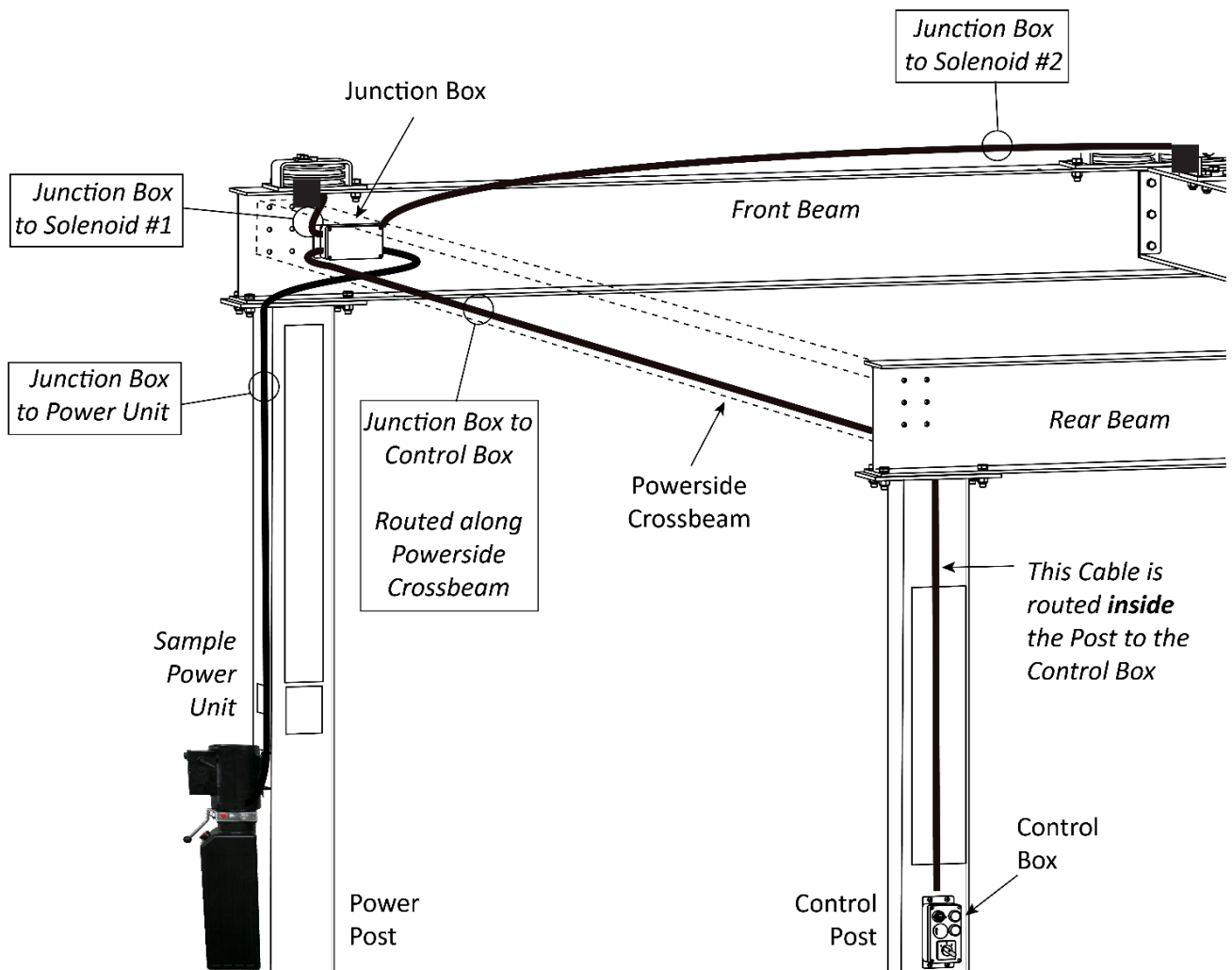

Note to Electrician: You need to **rewire the inside of the Electrical Box** based on the drawing in the [Wiring Diagrams](#).

⚠ WARNING Most of the required wiring must be provided by a licensed, certified Electrician; it is **not** supplied with the Lift. All control wiring must be a *minimum* of #16 AWG; note that local codes may require heavier gauge. BendPak recommends encasing all wiring to protect it from the outdoor elements and anchoring it so that it stays in place.

The wiring for the Controls requires:

- **Control Box to Junction Box:** 5 or 6 wires, depending on model. PL-6KDT/X requires 5 wires, PL-6KT requires 6 wires. The wires are: one per button (Key, Up, Down) and one wire per Platform.
- **Power Unit to Junction Box:** 3 or 4 wires, depending on Power Unit; see **Wiring Diagrams** and the drawing on the previous page for details.
- **Solenoids to Junction Box:** 2 wires per each Solenoid.

⚠ DANGER The following procedure **must** be performed by a certified, licensed Electrician in accordance with local and national electrical codes.

To connect the Controls:

1. Mount the Junction box on the Powerside end of the Front Beam using four Pan Head Screws M6 x 25 (5530318) and four M6 Nuts (5535112).
2. At the Control Box, connect the wiring per the drawings in **Wiring Diagrams**.
3. Route the Control Box wires through the back of the Control Box into the Control Post, then up and out through a hole at the top of the Control Post.
4. Connect the Control Box to the Control Post using four Pan Head Screws M6 x 16 mm (5530791).
5. Run the Control Box wires along the Powerside Crossbeam and then into the Junction Box. Encase and secure the wires.
6. Route the wires from the Electrical Box to the Junction box. Encase and secure the wires.
7. At each Solenoid, connect the wiring per drawings in the **Wiring Diagrams**.
8. Route the wires from each Solenoid to the Junction box. Encase and secure the wires.
9. At the Junction Box, connect the wiring coming from the Control Box, from the Power Unit, and from the Solenoids per the drawings in the **Wiring Diagrams**.

Install a Power Disconnect Switch

⚠ WARNING A main Power Disconnect Switch is **not** provided with this equipment.

Important: Your Lift has an Emergency Stop Button, which can stop the Lift immediately when pressed. This is a valuable safety tool, but it is not the same thing as a Power Disconnect Switch.

A Power Disconnect Switch is a National Electrical Code (NEC) requirement. They are designed to interrupt electrical power in the event of an electrical circuit fault, emergency situation, or when equipment is undergoing service or maintenance.

BendPak strongly recommends that you install a Power Disconnect Switch that is properly rated for the incoming power supply.

⚠ DANGER All wiring **must** be performed by a licensed, certified Electrician in accordance with local and national electrical codes.

Your Power Disconnect Switch must be readily accessible and installed so that it is in easy reach of the Lift operator. It must be clearly and legibly marked to indicate its purpose.

The figure to the right shows a toggle Power Disconnect Switch between the Lift's power source and its Power Unit. A quick flip of the switch immediately cuts power to the Lift.

Make sure to have a certified Electrician install the Power Disconnect Switch.

Make sure the Electrician selects and installs a UL-listed Power Disconnect Switch.

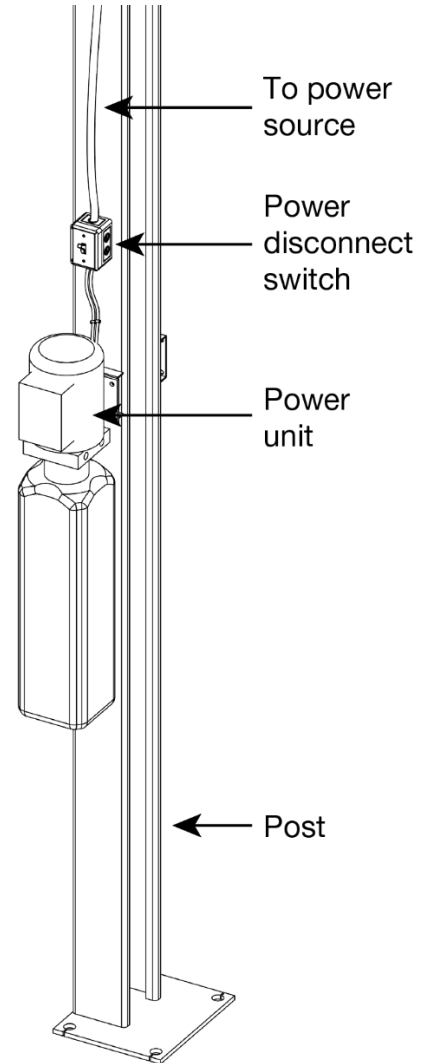

Install a Thermal Disconnect Switch

⚠ WARNING The Lift's motor does **not** have thermal overload protection.

Be sure to connect a motor Thermal Disconnect Switch or overload device that will make sure the equipment shuts down in the event of an overload or an overheated motor.

⚠ DANGER All wiring **must** be performed by a licensed, certified Electrician in accordance with local, state and national electrical codes.

High electrical current that exceeds the motor's full load ampere (FLA) rating may result in permanent damage to the motor.

BendPak strongly recommends you **not** exceed the rated duty cycle of the Lift's motor.

Anchor the Posts

If you have not done so already, you must anchor the four posts. Install one Anchor Bolt in each corner of each Base Plate, so 16 Anchor Bolts total. Anchor Bolt Assembly Part Number 5530337.

Concrete specifications are:

- **Depth:** 4.25 inches (108 mm) thick
- **PSI:** 3,000 PSI, minimum
- **Cured:** 28 days, minimum

Anchor Bolt specifications are:

- **Length:** 6.3 inches (160 mm)
- **Diameter:** $\frac{3}{4}$ inch (19 mm)
- **Effective embedment:** 3.25 inches (82.5 mm), minimum
- **Anchor torque:** 85 – 95 pound feet (no less than 80 or more than 105)

The Concrete floor where you want to install your Lift must meet the following requirements:

- The floor must be a flat, concrete floor. It must be level; **do not install the Lift on a surface with more than 3°**.
- Do not install the Lift on cracked or defective Concrete.
- Check the floor for the possibility of it being a post-tension slab. In this case, contact the building architect before drilling. Using ground penetrating radar may help you find the tensioned cable.

⚠ WARNING Your Concrete and Anchor Bolts must meet these specifications. Only install your Lift on a Concrete surface. If you install a Lift on asphalt or any other surface, or your Concrete or Anchor Bolts do not meet these specifications, it could lead to product damage, vehicle damage, personal injury, or even loss of life.

BendPak Lifts are supplied with installation instructions and concrete fasteners meeting the criteria as prescribed by the latest version of the American National Standard “Automotive Lifts – Safety Requirements for Construction, Testing, and Validation” ANSI/ALI ALCTV.

⚠ WARNING Use only the Anchor Bolts that came with your Lift. If you use components from a different source, you void your warranty and compromise the safety of everyone who installs or uses the Lift.

Lift buyers are responsible for conforming to all regional, structural, and seismic anchoring requirements specified by any other agencies and/or codes, such as the Uniform Building Code and/or International Building Code.

To anchor the posts:

1. Locate the hardware you will need: four Anchor Bolts, four Nuts, and four washers **per Post**.
2. Using the Base Plates as guides, drill the holes for the Anchor Bolts—one hole in each corner of the Base Plate, so four holes total per Base Plate.

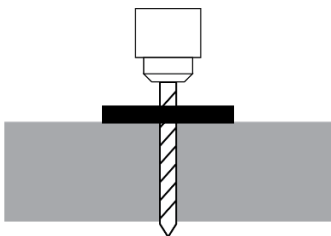

Go in straight, in the center of the hole; do not let the drill wobble.

Use a carbide bit (conforming to ANSI B212.15).

The diameter of the drill bit must be the same as the diameter of the Anchor Bolt. So if you are using a $\frac{3}{4}$ inch diameter Anchor Bolt, for example, use a $\frac{3}{4}$ inch diameter drill bit.

3. Vacuum each hole clean.

CAUTION Safety glasses and hand gloves are **required**.

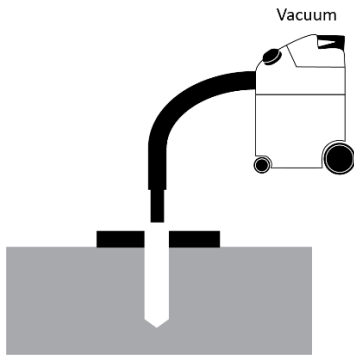

BendPak recommends using a vacuum to get the hole very clean. You can also use a wire brush, hand pump, or compressed air; just **make sure to thoroughly clean each hole**.

Do **not** ream the hole. Do **not** make the hole any wider than the drill bit made it.

Important: The holding strength of an Anchor Bolt is partially based on the how cleanly the Expansion Sleeve presses against the Concrete. If the hole is dirty, the Expansion Sleeve does not press as cleanly, which means less holding strength. If the hole is too wide, the Expansion Sleeve does not press against the Concrete with as much force, again resulting in less holding strength.

4. Make sure the Washer and Nut are in place, then insert the Anchor Bolt into the hole.

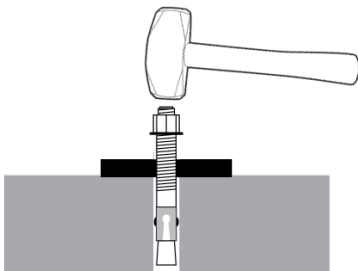

The Expansion Sleeve of the Anchor Bolt may prevent the Anchor Bolt from passing through the hole in the Base Plate; this is normal. Use a hammer or mallet to get the Expansion Sleeve through the Base Plate and into the hole.

Even using a hammer or mallet, the Anchor Bolt should only go into the hole part of the way; this is normal. If the Anchor Bolt goes all the way in with little or no resistance, the hole is too wide.

Once past the hole in the Base Plate, the Anchor Bolt eventually stops going down into the hole as the Expansion Sleeve contacts the sides of the hole; this is normal.

5. Hammer or mallet the Anchor Bolt the rest of the way down into the hole; stop when the Washer is snug against the Base Plate.
6. Plumb each Post; install any needed Shims.
7. Wrench each Nut **clockwise** to the recommended installation torque, 85 – 95 pound feet, using a Torque Wrench.

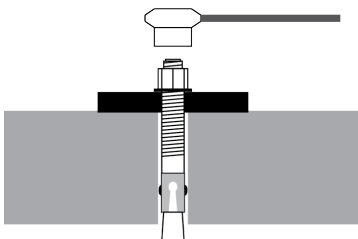

Important: Do **not** use an impact wrench to torque the Anchor Bolts.

Wrenching the Nut forces the Wedge up, forcing out the Expansion Sleeve and pressing it tightly against the Concrete.

Assemble the Platform Structures

Platform Structures support the Platform Sections, which together create a Platform. The following procedure covers assembling one Platform Structure. You will have to perform this procedure twice for the PL-6KD models, three times for the PL-6KT model.

Adding the Platform Sections and the Approach Ramp is described later in the installation.

NOTICE BendPak recommends assembling the Platform Structure on a raised platform, such as sawhorses. If the components are on the ground, it is more difficult to assemble the Platform Structure.

The following illustration shows how to arrange the Platform structure.

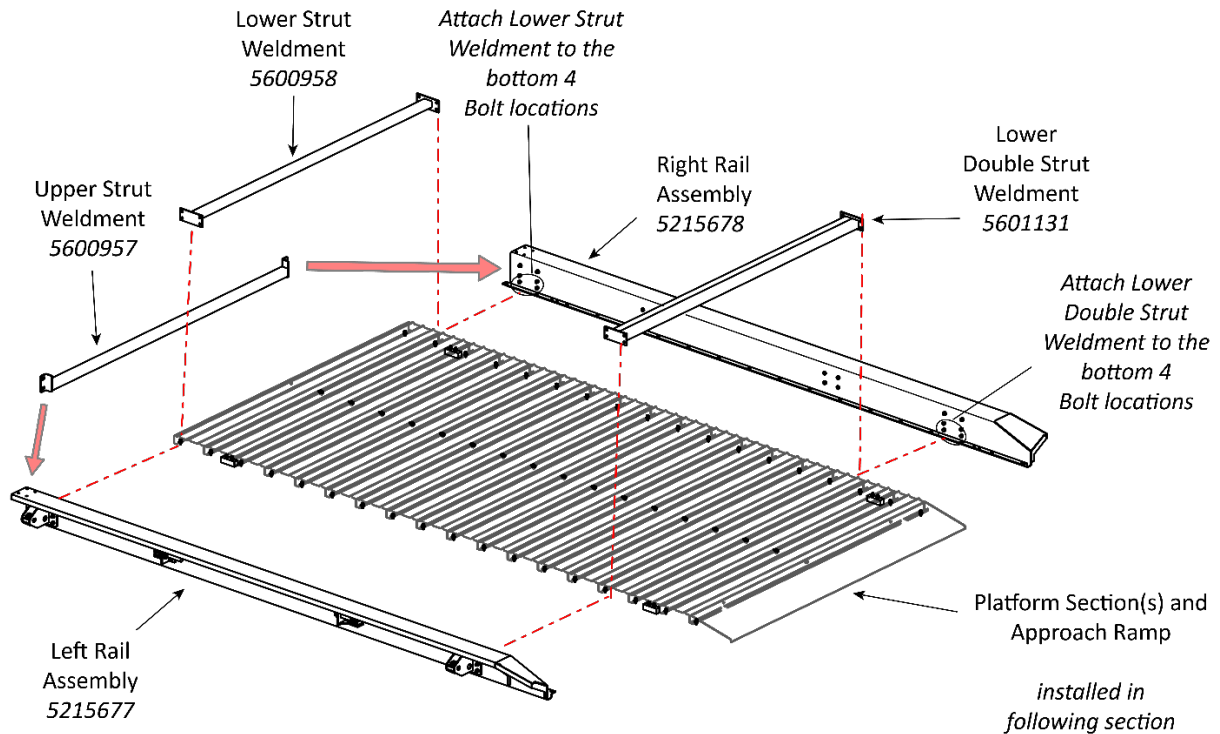

The following drawing shows the locations for the Cable Turns and Cable Locks on the Rail Assembly.

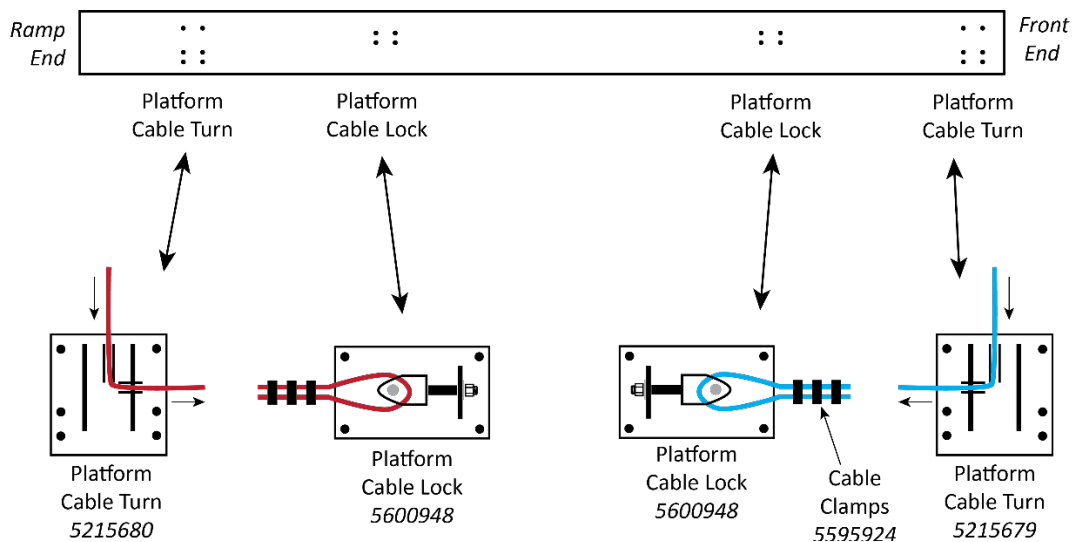

To assemble a Platform Structure:

1. Locate the pieces needed for one Platform Structure:
 - Two Rail Assemblies. One for the left side, one for the right side; they are **not** interchangeable.
 - Three Strut Weldments. Also **not** interchangeable – see drawing for **required** locations.
 - Four Platform Cable Turns. Two Cable Turns per each Rail Assembly.
 - Four Platform Cable Locks. Two Cable Locks per each Rail Assembly.
 - Cable Clamps. Three Cable Clamps per Cable.
 - Necessary Bolts, Washers, and Nuts.
2. Arrange all the pieces in their approximate positions.

Note: The Rail Assemblies are **not** interchangeable. Make sure you have one Left Rail Assembly and Right Rail Assembly, and that they are oriented correctly.

3. Attach the Platform Cable Locks and Cable Turns, making sure the Cable Turns are oriented correctly; the Cable Turns must be going towards the Cable Locks. *Do not torque the Nuts yet.*

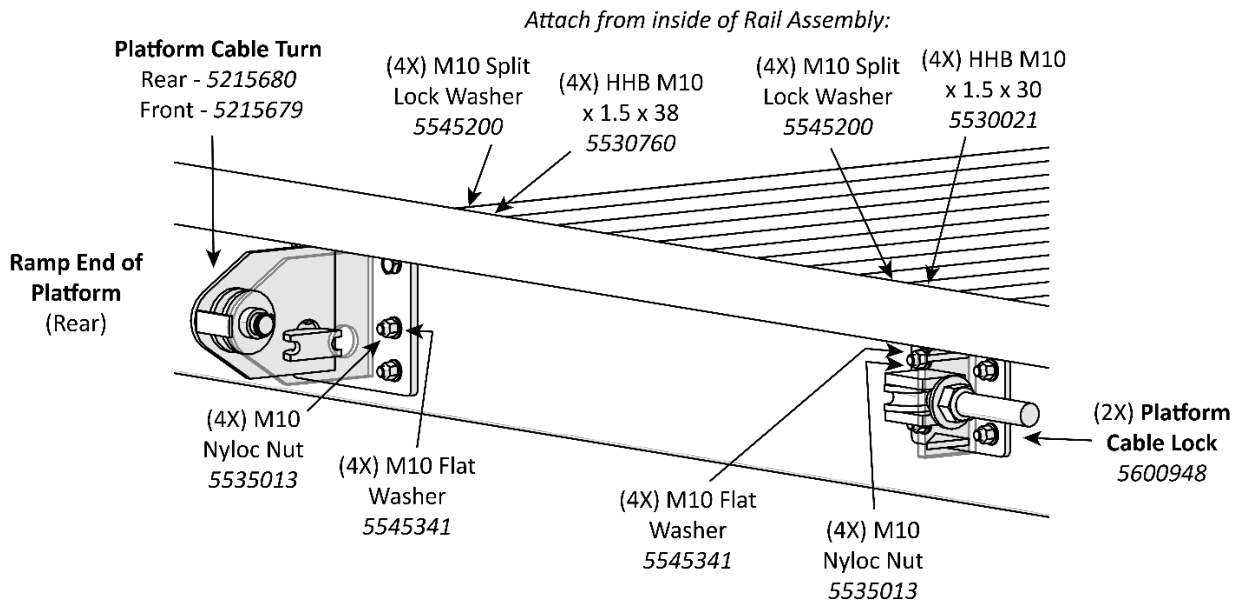

4. Put the Lower Double Strut Weldment into position, then connect one end through the Rail Assembly the four remaining holes in the Platform Cable Turn; connect the other end the same way; *do not torque the Nuts yet.*

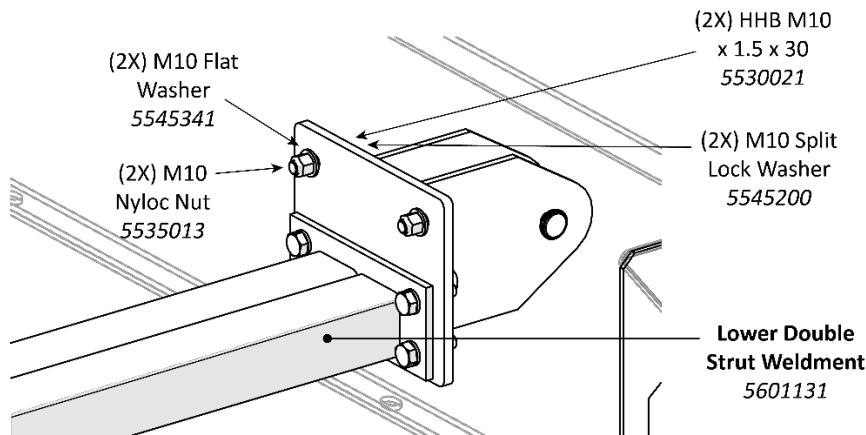

- Put the Lower Strut Weldment into position, then connect it through the Rail Assembly and the Platform Cable Turn, the same as the other Strut Weldment; *do not torque the Nuts yet.*
- Put the Upper Strut Weldment into position, then connect it on one end to the front of the Left Rail Assembly and the other end to the front of the Right Rail Assembly; *do not torque the Nuts yet.*

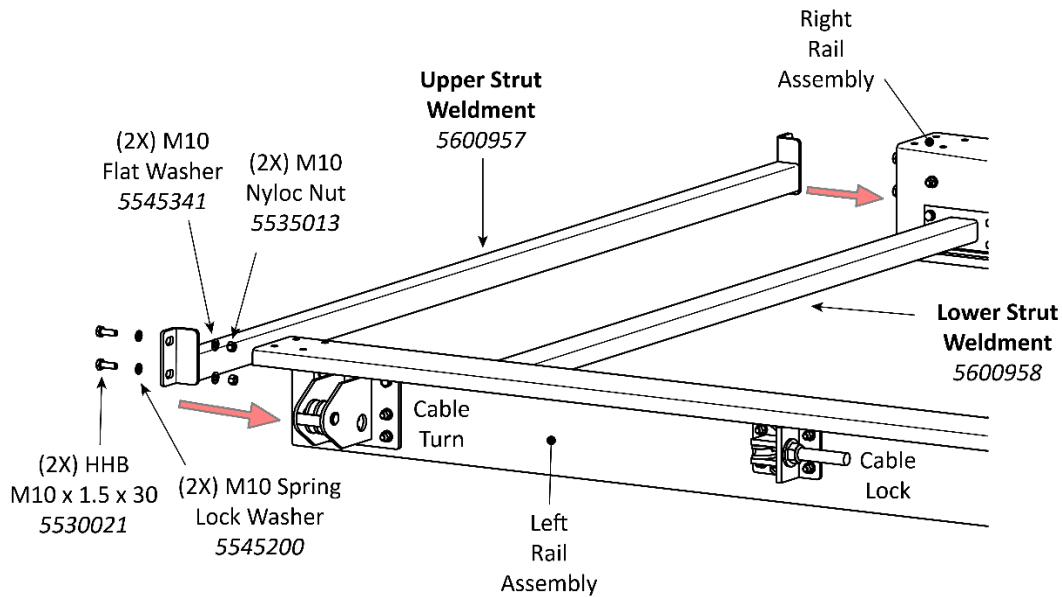

- For each of the four Cables for a Platform**, route each Cable through the Platform Cable Turn, towards the Platform Cable Lock, around the Sheave in the Platform Cable Lock, and back towards the Platform Cable Turn.

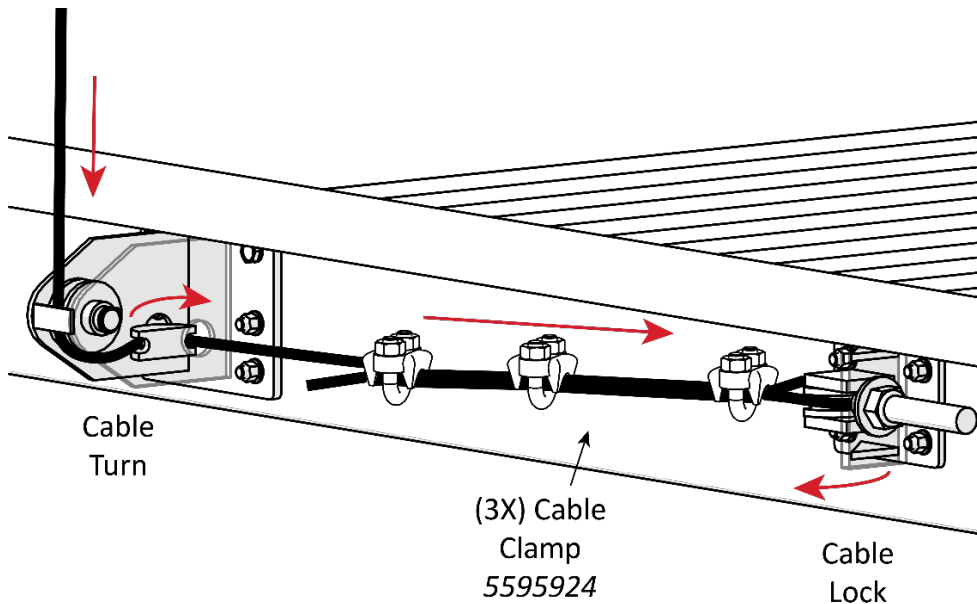

- Clamp the Cables together using the Cable Clamps; use the Cable Clamps that come with each Cable.

The Bolt side of the Cable Clamp **must** be facing up.

Torque the Cable Clamps to 75 ft. -lbf.

Install the Platform Sections and Approach Ramp

Each Platform is made up of multiple steel Platform Sections and an Approach Ramp.

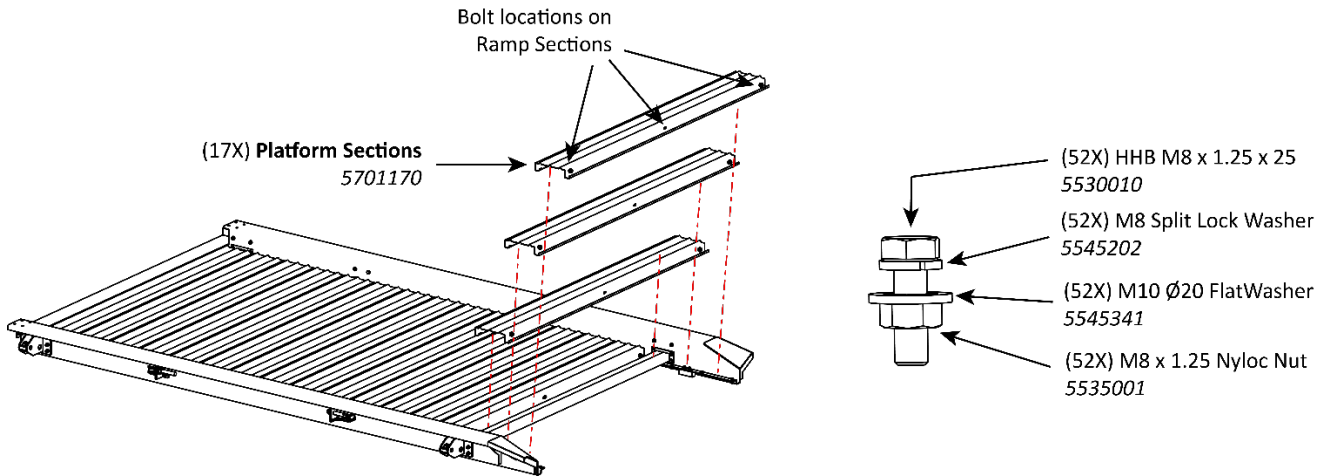

To install the Platform Sections:

1. Position the Platform Sections in place, starting from the front of the Platform and working your way to the Rear, where the Approach Ramp goes.

Make sure to overlap the Platform Sections as you put them into place; *do not bolt the Platform Sections yet.*

NOTICE You may find it easier to bolt the Platform Sections into place if you raise the Platform Structure so that you can walk under it. You are not required to do this, but you may find that it makes it easier to bolt the Platform Sections together. ***Make sure to place the Platform on its Safety Lock when you raise it.***

⚠ WARNING Do ***not*** walk underneath or perform any maintenance to the raised Platform until you have confirmed that the Platform is securely on a Safety Lock Position.

2. Take one Bolt, Spring Lock washer, Flat washer, and Nut, and install them into the holes in the Platform Sections.
3. When all of the Platform Sections are in place, attach the Ramp to the last Platform Section.

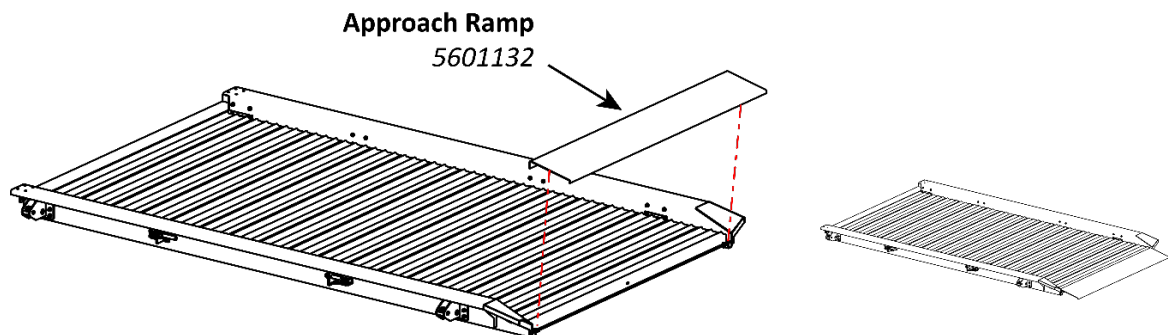

Operational Test

BendPak recommends performing an Operational Test of your Lift with a typical Vehicle **before** starting normal usage (a Vehicle is not required, but is recommended).

Performing an Operational Test will help you get a feel for how to operate the Lift and helps get any residual air out of the Hydraulic System.

During the Operational Test, watch the operating components and check for proper installation and operation. If you run into an issue that does not go away, refer to **Troubleshooting** for more information.

Note: Residual air in the Hydraulic System can cause the Lift to shake, move erratically, or squeak; this is normal. If it happens, do not worry; it will go away quickly as the Lift is a self-bleeding system.

To perform an Operational Test:

1. Check the area around and above the Lift for obstructions; move them if you find any.
2. If you are going to run the test with a typical Vehicle, drive it onto the desired Platform.
3. Insert the key, turn it to **ON**, then select the desired Platform.
4. Press and hold **Up**. The selected Platform starts rising.
5. When the Platform is about a foot off the ground, release **Up**. The Platform stops rising.
6. Press and hold **Down**. The Platform starts lowering.
7. When the Platform gets to the ground, it will stop lowering automatically. Release **Down**.
8. Wait for one minute.

 **CAUTION** The Power Unit's motor is **not** constant duty; it cannot be run continuously.

9. Repeat the process, this time raising the Platform to the Safety Lock.
10. If the Platform is working without shaking, moving erratically, or squeaking, there is no need to repeat the procedure.

If the Platform is shaking, moving erratically, or squeaking, this is perfectly normal during the start-up period. Repeat the procedure one or two more times, with a one-minute break between.

11. Perform the same test with the next Platform.
12. If you used a Vehicle, check the Platform Sections to make sure they stayed in place.
13. Check the Hydraulic Fluid reservoir on the Power Unit.

NOTICE Bleeding the Hydraulic System may significantly lower the amount of Hydraulic Fluid in the reservoir. Add additional Hydraulic Fluid, if necessary.

If there are issues that do not go away, refer to **Troubleshooting** for more information.

Final Checklist Before Operation

Make sure these things have been done before using your Lift:

- Review the **Installation Checklist** to make sure all steps have been performed.
- Make sure the Power Unit is getting power from the power source.
- Check the Hydraulic Fluid reservoir; it must be full of approved Hydraulic Fluid or automatic transmission fluid. **You can harm the motor by running it without enough fluid.**
- Check the Hydraulic System for leaks. Verify all Hydraulic Hose connections, Hydraulic Fittings, and Auxiliary Port Plugs on the Lift and Power Unit are tight.
- Check the Platform Sections to make they are bolted and in place.
- Make sure all Posts are properly anchored, shimmed, level, and stable.
- Make sure all Cables are taut, correctly routed and properly positioned in their Sheaves, and lubricated.
- Make sure that all Safety Locks are working normally.
- Make sure a copy of the *Installation and Operation Manual* is left with the Lift.
- If it has not been done already, perform an operational test of the Lift. Refer to **Performing an Operational Test**.

Operation

This section describes how to operate your Lift.

BendPak recommends reading *Lifting It Right* from the Automotive Lift Institute prior to putting your Lift into normal operation. It is a guide to the considerations involved with the safe operation of automotive Lifts. It was included with your Lift.

 **DANGER** When you even hear the words “automotive lift,” your brain should automatically remember that lifting a Vehicle is a serious endeavor with life-threatening risks. Focus on what you are doing. Automotive Lifts are dangerous tools when used by inexperienced or impaired operators. ***Do not assume you are going to be safe this time because nothing happened last time.***

Safety Considerations

Do the following before you raise or lower a Vehicle:

- **Check the Lift.** Walk all the way around the Lift, checking for any missing, heavily worn, or damaged parts. Always verify all Hydraulic connections including Hydraulic Fittings, Hoses, and Auxiliary Ports are secure. Do not operate the Lift if you find any issues; instead, take it out of service, then contact your dealer, email support@bendpak.com, or call **(800) 253-2363**.
- **Check the area.** Keep the area around the Lift clean and free of obstructions; anything that could cause a problem for the Lift. Do not forget to check **above** the Lift. If you find an obstruction, move it out of the way. If you find any other issues, resolve them before using the Lift. Do not allow anyone or anything within 30 feet of the Lift while it is in motion.
- **Check the operators.** Make sure that everyone who is going to operate the Lift has been trained in its use, has read the Labels on the unit, and has read the Manual. Only the operator at the Console should be within 30 feet of the Lift when it is in motion.

Do not allow children to operate the Lift. Do not allow anyone under the influence of drugs or alcohol to operate the Lift. Do not allow any unauthorized personnel to operate the Lift.

When the Lift is moving, the Operator must be paying full attention to the Lift and the area around it. The Operator must not be looking down at a smart phone, talking to a co-worker, or be distracted in any other way.

- **Check for safety.** Make sure everyone who is going to be walking near the Lift is aware of its presence and takes appropriate safety measures. Only put Vehicles on the Platforms. ***When raising a Vehicle, do not leave it until it is on the Safety Lock.*** When lowering the Lift, do not leave it until it is on the ground.
- **Check the vehicle.** Never exceed the Lift’s weight rating. Do not allow people inside a Vehicle you are going to raise. Take out of the Vehicle anything you might need while it is up on the Lift. Make sure the Vehicle is not overbalanced on either end or either side.

Using the Control Box

This section describes how to use the Control Box.

PL-6KD Models:

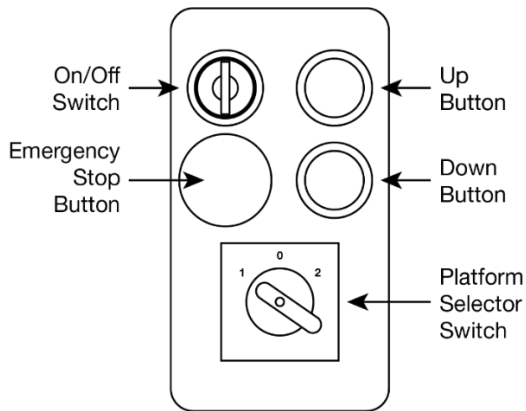

PL-6KT:

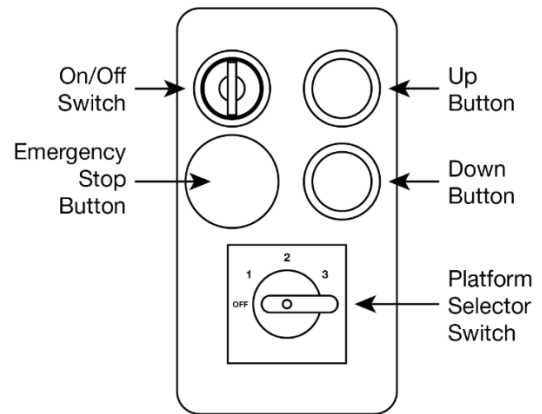

The **Control Box** controls your Lift:

- The **ON/OFF Switch** is a security device; you must have the key in and **ON** for operation.
- The **Emergency Stop Button** stops the Lift immediately when pressed. Use this if an unexpected and/or dangerous situation arises. When pressed, the button physically goes in and locks. To release the **Emergency Stop Button**, twist it clockwise until it pops back out.
- The **Up** and **Down** buttons raise and lower the selected Platform.
- The **Platform Selector Switch** selects which Platform can be raised or lowered. The PL-6KD models have a three-position switch: select **1** to control the Powerside Platform, select **2** to control the Offside Platform, select **0** when not using the Lift.

The PL-6KT has a four-position switch: select **OFF** when not using the Lift, select **1** to control the Powerside Platform, select **2** to control the Center Platform, select **3** to control the Offside Platform.

Raising and Lowering Vehicles

Keep the following in mind when operating your Lift:

- **Be safe.** Make sure to check for people, pets, and objects that might be in the path of the Lift as you raise or lower it. Watch the Lift carefully as it raises and lowers.
- **⚠ DANGER** Pay careful attention when you are raising or lowering the Platforms. If a person or pet gets stuck under the Platform, they could be injured or, in rare cases, killed.
- **Platforms operate independently.** Each Platform on the Lift operates independently; you must verify the **Control Box** setting and verify you are raising or lowering the desired Platform.
- **Vehicles must be on the Platform.** Vehicles need to be centered on the Platform, width-wise. All four wheels must also be fully on the Platform, not the ramp or side structures.
- **The Emergency Stop button is there for a reason.** We hope you never have to use it, but if something unexpected happens, use the **Emergency Stop** button to immediately stop the Lift from moving.
- **Get what you need out of the Vehicle before lifting it.** It is annoying to raise a vehicle and then realize you left something inside.

To raise a Vehicle:

1. On the Control Box, verify the **On/Off Switch** is **ON** and the desired Platform is selected.
2. Make sure the Platform is on the ground. If it is not, move it *all the way down to the ground*.
3. Drive a Vehicle onto the Platform.

Make sure all four wheels are fully on the Platform, not on the ramp or the side structure. Make sure the Vehicle is centered on the Platform, width-wise.

Put the Vehicle into park and put on the parking brake. If it is a manual transmission, make sure it is in a gear, not in neutral.

4. On the Control Box, press and hold **Up**.
5. When the desired height is reached, release **Up**, then press and hold **Down** for two or three seconds to push the Safety Rod down into the Safety Lock Cavity.

The Platform is now engaged on its Safety Lock.

Note: If you do not release **Up** quickly enough, the Safety Rod will go past the Safety Lock Cavity, and you will not be able to engage the Platform on its Safety Lock. What happens when you go back **Down** for two or three seconds is that the Safety Rod will go past the Safety Lock Cavity, not into it. If this happens, simply repeat Steps 4 and 5, making sure to release **Up** when the Safety Latch comes down.

6. Check around the Vehicle and the Platform to make sure everything is safe, then set the Control Box to **0** or **OFF**, depending on the Model you are using. If you see an issue, fix it.
7. If you are not going to be using the Lift any further, turn the **ON/OFF Switch** to **Off** and then remove the key.

 **CAUTION** The On/Off Switch *must* be in the **OFF** position when the Lift is not in use.

8. Drive a Vehicle under the raised Platform.

To lower a Vehicle:

1. Make sure there is nothing under the Platform you are about to lower.
If there is, move it out of the way.

2. Insert the key into the **ON/OFF Switch**, turn it to **ON**, and select the desired Platform.

3. On the Control Box, press and hold **Up** for four or five seconds, then press and hold **Down**.

Pressing and holding **Up** for four or five seconds is required. It moves the Safety Rod out of the Safety Lock Cavity and puts the Release Cam in the right place in relation to the Lock Block, both of which are needed for the Safety Lock to be bypassed, allowing the Platform to go down.

4. When the Platform gets to the ground, release **Down**.
5. If you are not going to be using the Lift any further, turn the **ON/OFF Switch** to **OFF** and then remove the key.
6. Make sure it is safe to drive the Vehicle off the Lift.
7. Drive the Vehicle off the Platform.

Maintenance

 **DANGER** Before performing any maintenance on your Lift, make sure it is completely disconnected from power. Do not reconnect it until all maintenance procedures are finished. The Lift uses electrical energy; if your organization has Lockout/Tagout policies, make sure to implement them **before** performing any maintenance. If you come into contact with high voltage/current, you could be injured or killed.

If you need to replace worn, damaged, or broken parts, you **must** use parts from (or approved by) the original equipment manufacturer (OEM) or parts that meet the OEM's specifications. Unless stated otherwise, all maintenance may be performed by the owner/employer and does not require trained lift service personnel.

 **WARNING** If you use parts not from, approved by, or meeting the specifications of the original equipment manufacturer, you void your warranty and compromise the safety of everyone who installs or uses the Lift.

To maintain your Lift:

- **Daily:** Keep the Lift clean. Wipe up any spills, clean any dirt.
- **Daily:** Make a visual inspection of all moving parts and check for damage or excessive wear. Replace any damaged or worn parts before using the Lift.

 **DANGER** Do not use the Lift if the Lifting Cables are damaged or extremely worn. If a Vehicle is raised when you notice the damage or extreme wear, very carefully lower the Vehicle to the ground if this can be done safely; if it cannot be done safely, evacuate the area and make arrangements with trained lift service personnel to lower the Vehicle. When the Lift is on the ground, take it out of service, disconnect it from power, and make arrangements with trained lift service personnel to fix the damage and/or wear.

- **Daily:** Make sure the Safety Lock is working correctly.

 **WARNING** Do **not** use a Platform if its Safety Lock is damaged or excessively worn.

- **Weekly:** Check all Controls, including Emergency Stop, to make sure they are functioning.
- **Weekly:** Check all Labels on the Lift. Replace them if they are illegible or missing.
- **Monthly:** Check Hydraulic Fluid levels. Refill if low.
- **Monthly:** Check Cable connections, bolts, and pins for proper mounting and torque.
- **Every two months:** Check all Anchor Bolts to make sure they are correctly tightened. If they are not, tighten them.
- **As needed.** Take the Lift out of service and then replace the Lifting Cables if there are signs of damage or extreme wear.

 **WARNING** Do not operate your Lift if you find maintenance issues; instead, take the Lift out of service, then contact your dealer, visit [bendpak.com/support](https://www.bendpak.com/support), email support@bendpak.com, or call **(800) 253-2363**.

Wire Rope Inspection and Maintenance

Your Lift's wire rope should be inspected regularly:

- Lifting Cables should be replaced when there are visible signs of damage or extreme wear. ***Do not use the Lift if it has damaged or worn cables; you must take it out of service!***
- Lifting Cables should be maintained in a well-lubricated condition at all times.

Wire rope is only fully protected when each wire strand is lubricated both internally and externally. Excessive wear shortens the life of wire rope.

Use a wire-rope lubricant that penetrates to the core of the rope and provides long-term lubrication between each individual strand, such as 90-WT gear oil or ALMASOL® Wire Rope Lubricant.

To make sure that the inner layers of the rope remain well lubricated, lubrication should be carried out at intervals not exceeding three months during operation.

- All Sheaves and guide rollers in contact with the moving rope should be given regular visual checks for surface wear and lubricated to make sure they run freely. This should be done at least every three months during normal operation.

For all Sheave axles, use standard wheel bearing grease. For all Sheaves and/or guide rollers, use 90-WT gear oil or a similar heavy lubricant, applied by any method including pump/spray dispensing, brush, hand, or swabbing.

- How often should you inspect?

Lifting Cables should be visually inspected at least once each day when during normal operation, as suggested by American Petroleum Institute's Recommended Practice 54 guidelines.

Any lifting Cables that have met the criteria for removal must be *immediately* replaced.

- When should you replace lifting Cables due to broken wires?

Lifting Cables should be removed from service if you see six randomly distributed broken wires within any one lay length or three broken wires in one strand within one lay length.

- Are there other reasons to replace your lifting Cables?

Yes:

- Corrosion that pits the wires and/or connectors
 - Evidence of kinking, crushing, cutting, bird-caging, or a popped core
 - Wear that exceeds 10% of a wire's original diameter
 - Evidence of heat damage
- How do you find broken wires?
 - a. Relax your rope to a stationary position and move the pick-up points off the Sheaves. Clean the surface of the rope with a cloth — a wire brush, if necessary — so you can see any breaks.
 - b. Flex the rope to expose any broken wires hidden in the valleys between the strands.
 - c. Visually check for any broken wires. One way to check for crown breaks is to run a cloth along the rope to check for possible snags.
 - d. With an awl, probe between wires and strands and lift any wires that appear loose. Evidence of internal broken wires may require a more extensive rope examination.

Troubleshooting

This section describes how to troubleshoot your Lift.

Important: If your Lift is not functioning correctly, you must take it out of service until it is fixed. All repair work **must** be done by qualified personnel. If you continue having issues, take the Lift out of service, then contact your dealer, visit bendpak.com/support, email support@bendpak.com, or call **(800) 253-2363**.

⚠ WARNING The Lift uses electrical energy; if your organization has Lockout/Tagout policies, ensure to implement them **before** performing any maintenance or troubleshooting.

Lift does not raise or does not lower, once raised.	<p>Verify there is sufficient Hydraulic Fluid in the reservoir.</p> <p>Verify there is no air in the Hydraulic System.</p> <p>Verify none of the Hydraulic Lines are pinched or leaking.</p> <p>Verify the Power Unit is getting power. If the Hydraulic Fluid is dirty, replace it with clean fluid.</p> <p>Make sure Lift is not overloaded.</p> <p>If the Lift will not lower after verifying, contact BendPak Support at (800) 263-2363 ext. 196</p>
Platforms move erratically or squeak when in use.	<p>Move the platforms up and down a few times to flush any residual air from the Hydraulic System.</p>
Lift does not stay up.	<p>Check for leaking Hydraulic Fluid.</p> <p>Make sure the Lift is left on its Safety Lock.</p>
Motor not running.	<p>Check the connection to the power source; make sure it is plugged in and of the appropriate voltage.</p> <p>Check the wiring diagram.</p>
Hydraulic Fluid is dirty.	<p>Replace the dirty fluid with clean, approved Hydraulic Fluid: any general purpose ISO-32, ISO-46, or ISO-68 hydraulic oil; Dexron III, Dexron VI, Mercon V, Mercon LV, Shell Tellus S4 / S3 / S2; or a synthetic, multi-vehicle automatic transmission fluid.</p>
Lift makes odd noises.	<p>Lubricate the bushings on the Sheaves on the sides of the crossbeams using white lithium grease. If the Lift is new, a break-in period may be needed; run the Lift several times each day. If the noises persist, contact BendPak Support.</p>

If you continue to have issues with your Lift, take it out of service, then contact your dealer, go to bendpak.com/support, email support@bendpak.com, or call **(800) 253-2363**, ext. 196.

Disposing of Hydraulic Fluid

Hydraulic Fluid **cannot** be disposed of by dropping it into the trash or dumping it into the street. It has toxic ingredients that are harmful to the environment.

Instead, you need to either recycle it or drop it off at a hazardous waste collection facility.

Rags and/or granular absorbents that have soaked up Hydraulic Fluid should also be treated like hazardous waste and be disposed of at a hazardous waste collection facility.

To find an appropriate facility:

- Local automotive parts stores, auto care facilities, or automobile dealerships may accept fluid for recycling or, in some cases, for disposal. Contact them for more information.
- Cities, counties, and states often support both recycling facilities and hazardous waste collection facilities. Contact them to see if and where they have these programs.
- If you have large amounts of fluid, consider contacting a commercial waste disposal company.

In all cases, the best approach is to find an appropriate facility and contact them — in advance — to ask them: what kinds of fluids they accept, what kind of containers it must be in, what hours they are open, their location, and any other information specific to their facility.

If you are unable to find an appropriate facility, the website [earth911.com](https://www.earth911.com) has resources that may be of help.

Wiring Diagrams

⚠ WARNING All electrical work **must** be performed by a licensed, certified Electrician in accordance with all applicable local, state and national electrical codes. **Damage caused by improper electrical installation may void your warranty.**

PL-6KD Models (220V, 1Ph):

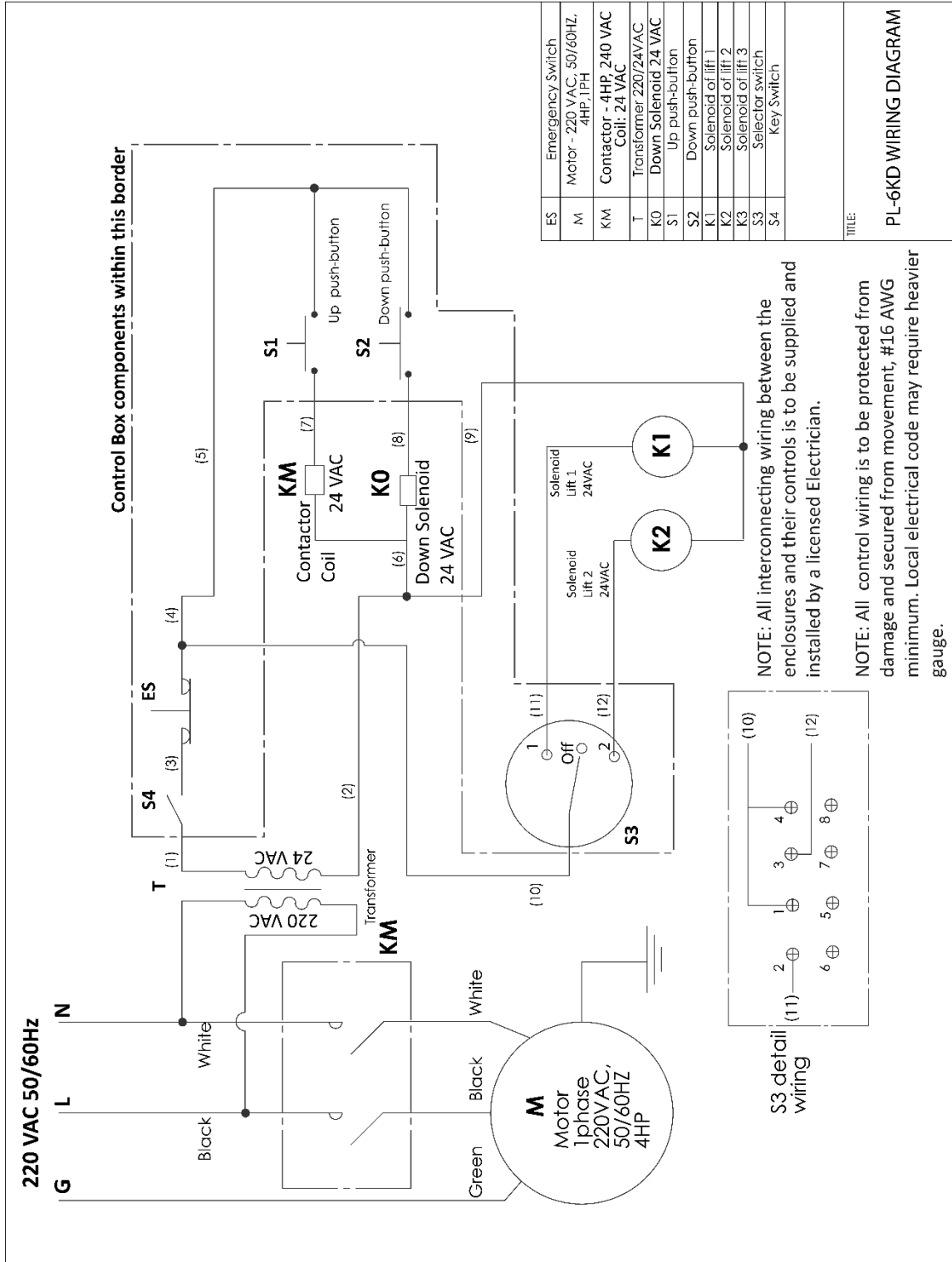

⚠ WARNING All electrical work **must** be performed by a licensed, certified Electrician in accordance with all applicable local, state and national electrical codes. **Damage caused by improper electrical installation may void your warranty.**

PL-6KT (220V, 1Ph):

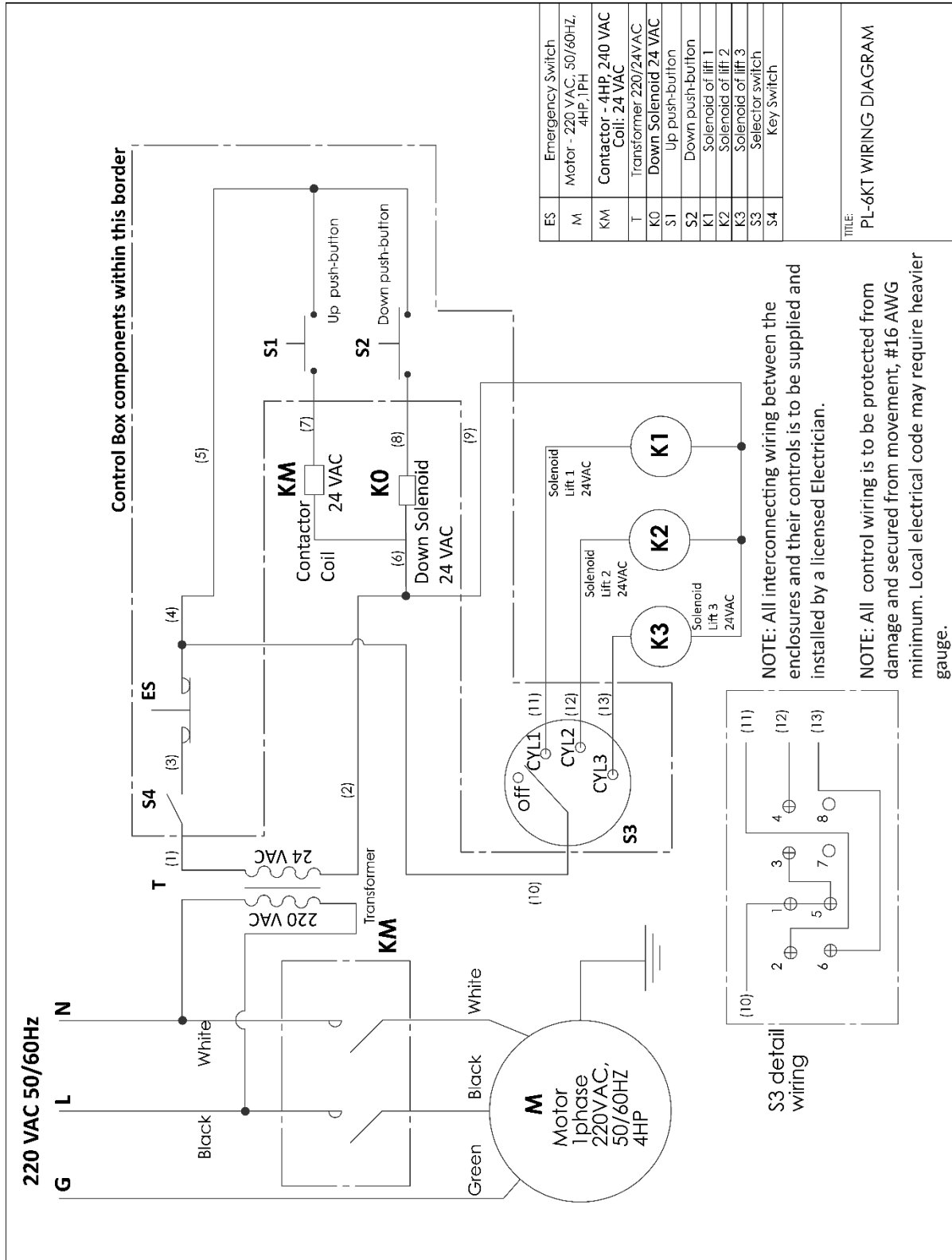

⚠ WARNING All electrical work **must** be performed by a licensed, certified Electrician in accordance with all applicable local and national electrical codes. **Damage caused by improper electrical installation may void your warranty.**

PL-6KD Models (220V, 1Ph) – Simplified version

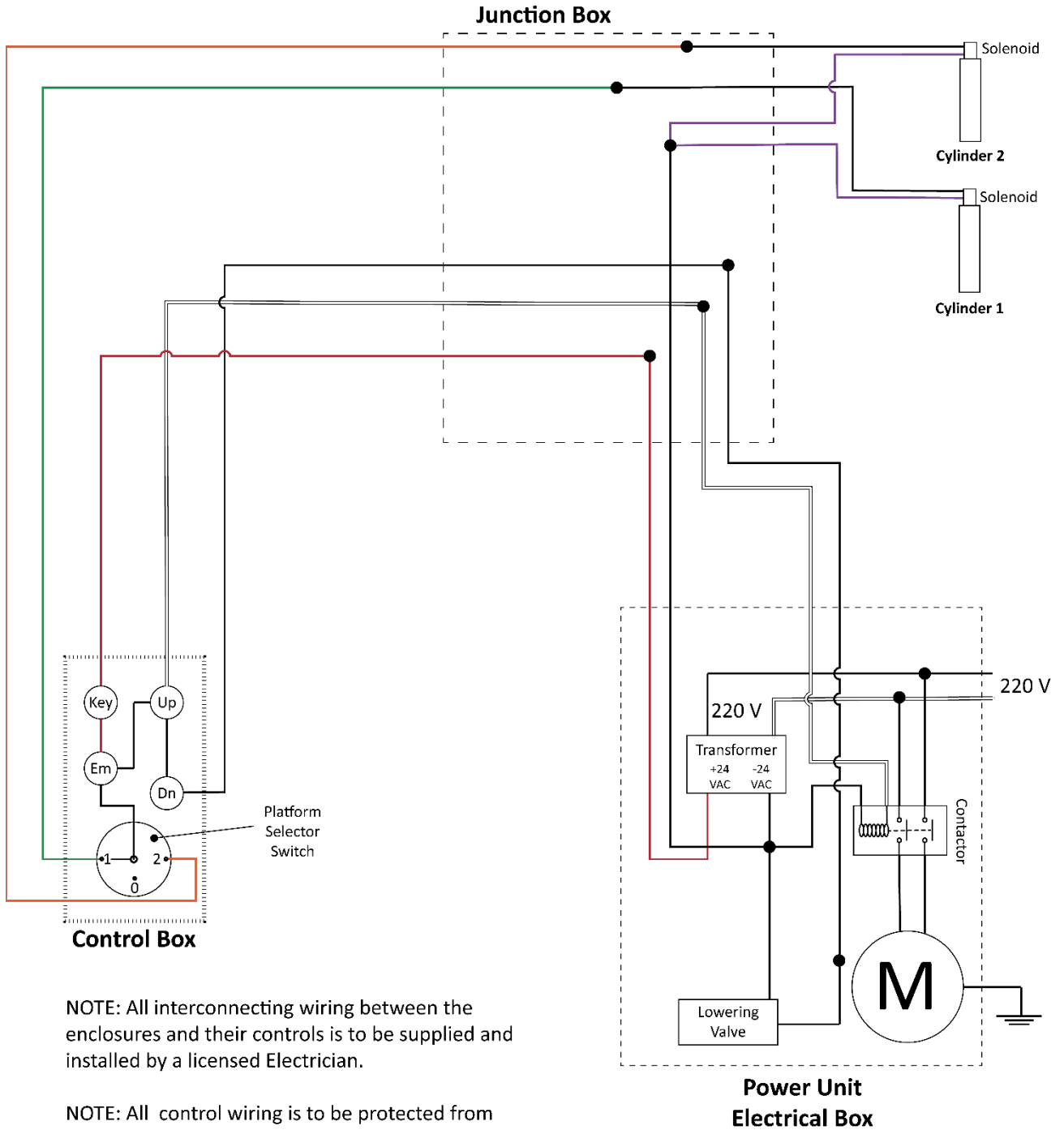

NOTE: All interconnecting wiring between the enclosures and their controls is to be supplied and installed by a licensed Electrician.

NOTE: All control wiring is to be protected from damage and secured from movement, #16 AWG minimum. Local electrical code may require heavier gauge.

⚠ WARNING All electrical work **must** be performed by a licensed, certified Electrician in accordance with all applicable local and national electrical codes. **Damage caused by improper electrical installation may void your warranty.**

PL-6KT (220V, 1Ph) – Simplified version

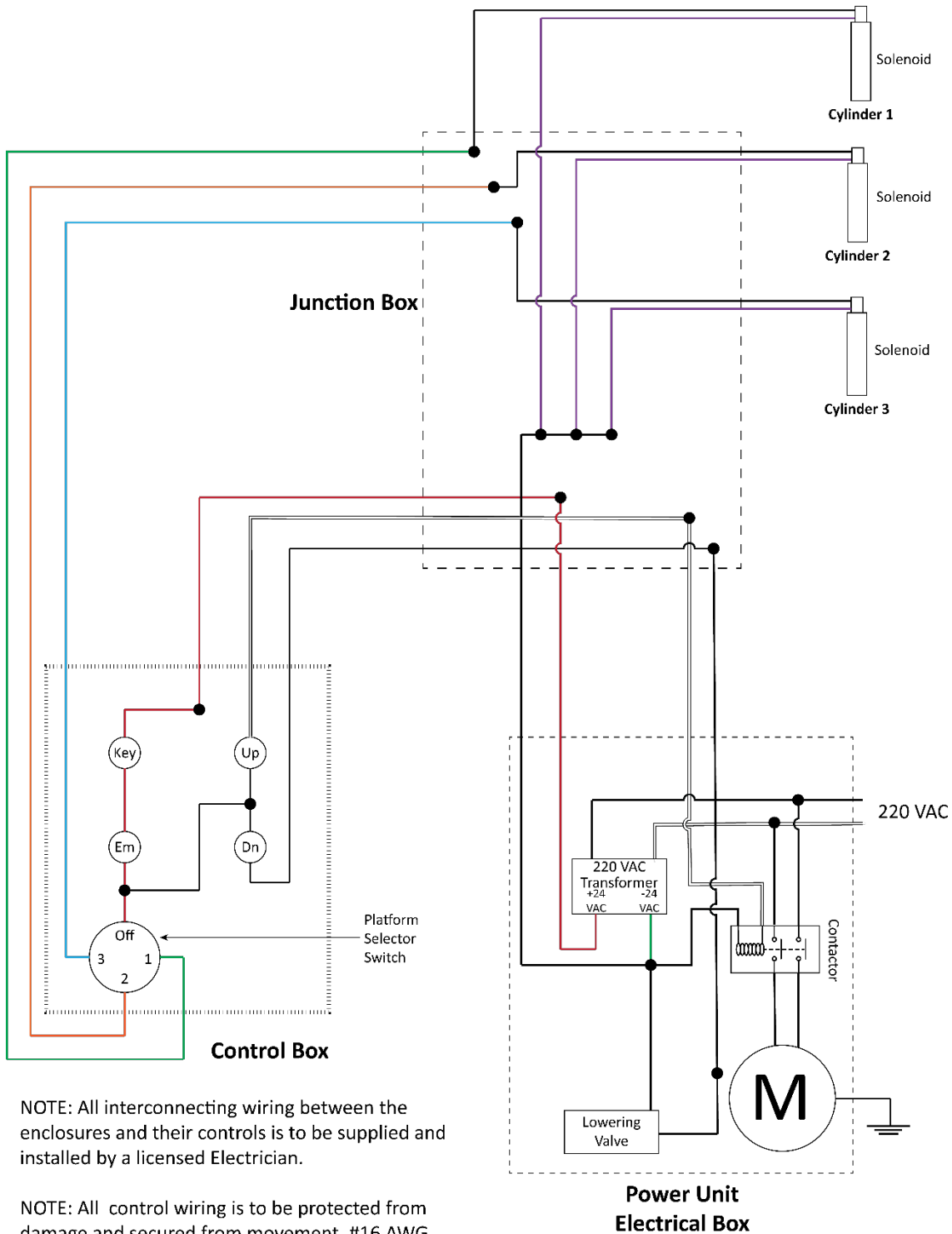

NOTE: All interconnecting wiring between the enclosures and their controls is to be supplied and installed by a licensed Electrician.

NOTE: All control wiring is to be protected from damage and secured from movement, #16 AWG minimum. Local electrical code may require heavier gauge.

Labels

A



B

DANGER-PELIGRO

**Remain clear of lift at all times when raising or lowering vehicles.
> NO RIDERS ON PLATFORMS <
Trained operators only are to use lift.**

⚠ WARNINGS

- Read the entire operation manual, warnings and operative instructions before using the lift.
- If any questions arise as to the safety or operation of this lift, contact your property manager, building engineer, authorized dealer or authorized service center.
- NEVER leave the lift unattended while partially raised or lowered.
- Always use caution when operating this lift. Never allow children or persons under the influence of drugs or alcohol to use or maintain this lift.
- Serious injury, property damage, and/or death can occur if this lift is improperly used or maintained.
- KEEP ALL OBJECTS, HANDS AND FEET CLEAR AT ALL TIMES. Never place hands, arms or feet near any moving parts during operation. Serious injury or death can occur.
- ALWAYS double-check under clearance obstacles during vehicle under lift platform. ALWAYS double-check overhead clearance BEFORE raising lift platform.
- Only trained operators should operate this lift. All non-trained personnel should be kept away from work area. Never let non-trained personnel come in contact with, or operate lift.
- Ground against electric shock. This lift must be grounded when in use to protect the operator from electric shock.
- Risk of explosion. This lift has internal wiring or sparking parts which should not be exposed to flammable vapors.
- Maintain lift with care. Keep lift clean for better and safe performance. Follow manual for proper lubrication and maintenance instructions. Keep control handles and/or buttons dry, clean and free from grease and oil.
- Stop lift - watch what you are doing. Use common sense and always be aware.
- Check for damaged parts. Check for alignment of moving parts, breakage of parts or any condition that may affect safe operation of the lift. Do not use lift if any component is broken or damaged.
- Never remove safety related components, structure or warning signs. Do not use any safety related components, indication or warning labels are damaged or missing.

OPERATION INSTRUCTIONS

Read the entire operation manual and warning instructions shown above before operating this parking lift.

IMPORTANT NOTE

The parked and locked position of the lift determines the height of the vehicles that can be safely parked underneath the lift. Make sure that you are using only vehicles that are of the proper height for the parked and locked setting.

PLACEMENT OF UPPER VEHICLE / PRE-LIFTING PROCEDURE

- Drive the vehicle onto the covering platform. Vehicles may be driven in nose first or backed in.
- Be sure that all of the vehicle tires are resting securely on the platform surface. Never raise a vehicle with its tires partially on the platform or on the raised portion of the platform or curb.
- Turn off all engine, engine safety brake, and place the vehicle's gear selector in Park. If vehicle is manual transmission, place the transmission in first gear.
- Walk around the lift to ensure no obstructions will interfere with the vehicle being lifted.
- Position yourself within reach of the operator controls and clear all moving parts and pinch points.

LIFTING PROCEDURE

- With the vehicle safely positioned on the lift platform, check the lift perimeter to ensure that no objects are in the platform's way, and that no persons except for lift operator are within 10 feet.
- During operation, observe the entire perimeter of the lift to ensure there are no obstructions that may damage vehicle and/or lift.
- Position the key switch on the control panel to ON.
- Position the selector switch on the control panel to station 1 or 2 (if double wide model) or 1 thru 3 (if single wide model). NOTE: Station 1 will always be closest to control panel.
- Press and hold the UP button until the lift platform reaches the parking position. NOTE: When the parking position is reached, you will visually see the safety lock bar drop down into the stationary lock rail.
- WARNING - NEVER accidentally raise the lift beyond the parking position. If the lift platform is raised too far, the safety release releases all cranes which would deactivate the lock lockers.
- After reaching the parking position, release the UP button. Then press and activate the DOWN button to lower and park the platform. Press and hold the DOWN button until the platform reaches the stationary lock rail. Once downward movement stops, release the DOWN button.
- Always use the platform until it reaches the parking position. Never stop or pause the midway between the floor and parking position.
- Never purposely walk under the raised platform - always walk around and stay clear of all times.

▶ **IMPORTANT NOTE - Activate the RED EMERGENCY STOP button to stop lift operation at any time.** ◀

LOWERING THE LIFT

- Walk around the lift to make sure nothing is below or near the lift platform's entire lower area to prevent the descent.
- Be certain that no persons except the lift operator are within 10 feet of the lift area.
- Press and activate the UP button for three to five seconds to activate the lift platform enough to allow activation of the mechanical lock release device.
- Release the UP button three times and activate the DOWN button to lower and park the platform to the floor. Once downward movement stops, release the DOWN button.
- When lowering lift platform always be watchful for objects, persons or animals that may wander under the lift platform during operation.
- Maintain visual contact with lift platform during all operations.

▶ **WARNING - Immediately cease operation if platform become unlevel or if area becomes obstructed.**

- Platform will continue to lower as long as you have the DOWN button activated.
- Continue lowering the platform until convenient movement stops and the lift settles on the floor.
- Release the DOWN button.
- Carefully drive off the vehicle off the lift platform only after making sure all is clear before exiting the lift area.

MOVING MACHINERY

KEEP HANDS AND FEET CLEAR AT ALL TIMES

MANTENGA LAS MANOS Y LOS PIES ALEJADOS EN TODO MOMENTO

⚠ WARNING

PARKING LIFT WIRE ROPE INSPECTION AND MAINTENANCE

- Lifting cables should be replaced every (5) five years or when visible signs of damage are apparent. DO NOT USE LIFT WITH DEFECTIVE OR WORN CABLES.
- Wire rope should be maintained in a well-lubricated condition at all times. Wire rope is only fully protected when each wire strand is lubricated both internal and external. Excessive wear will shorten the life of the wire rope. The factory suggests wire rope lubricant that penetrates to the core of the rope remain well lubricated. Lubrication should be carried out at intervals not exceeding three (3) months during operation.
- All sheaves and pulleys rollers in contact with the moving wire rope should be given regular visual checks for surface wear and lubricated to make sure that they run freely. This operation should be carried out at appropriate intervals generally not exceeding three (3) months during operation. The factory recommends applying wheel bearing grease or similar heavy lubricant, through the use of a grease gun, to the zerk fittings of the sheave axles and sheaves.

Failure to read, understand and follow these instructions may cause death or serious injury. Read and understand these instructions before using lift.

C

on following page

PL-6KDT / X

DOUBLE WIDE MODEL ONLY

D

⚠ DANGER

THE MAXIMUM LIFTING CAPACITY FOR THIS LIFT IS DESCRIBED BELOW

Max Lifting Capacity / Total All Decks
12,000 lbs. / 5443 kg
Max Lifting Capacity / Per Deck
6,000 lbs. / 2722 kg

Exceeding the weight capacity of this lift can damage lift and/or property and may cause personal harm, injury or death to operators and/or bystanders. All vehicles MUST be centered on lifting platforms. Damage to lift due to overloading or misuse IS NOT covered under warranty.

Copyright 2016 BendPak Inc. P/N 5905612

E

PL-6KT

TRIPLE WIDE MODEL ONLY

⚠ DANGER

THE MAXIMUM LIFTING CAPACITY FOR THIS LIFT IS DESCRIBED BELOW

Max Lifting Capacity / Total All Decks
18,000 lbs. / 8165 kg
Max Lifting Capacity / Per Deck
6,000 lbs. / 2722 kg

Exceeding the weight capacity of this lift can damage lift and/or property and may cause personal harm, injury or death to operators and/or bystanders. All vehicles MUST be centered on lifting platforms. Damage to lift due to overloading or misuse IS NOT covered under warranty.

Copyright 2016 BendPak Inc. P/N 5905999

F

⚠ ATTENTION ⚠

6000 Lbs.

2722 Kg.

THIS PLATFORM MAXIMUM LIFTING CAPACITY

P/N 090603

C**G**

BP BendPak. Santa Paula, CA USA www.bendpak.com	
MODEL NUMBER	
DESCRIPTION	
LIFT CAPACITY	DATE CODE
VOLTAGE	SERIAL NUMBER
<input type="checkbox"/> 110-120V, 50-60 Hz, 1 Ph	UPC
<input type="checkbox"/> 208-240V, 50-60 Hz, 1 Ph	
<input type="checkbox"/> 380-415V, 50-60 Hz, 3 Ph	
<input type="checkbox"/> 208-440V, 50-60 Hz, 3 Ph	
DANGER! Disconnect Power Before Servicing	EAC
MADE IN CHINA	WARRANTY VOID IF DATA PLATE IS REMOVED PN 5905951

I

	⚠ WARNING SLIPPERY WHEN WET OR ICY Use caution when driving onto wet or icy drive-up ramps and platforms. DO NOT walk on lift surfaces that are wet or icy.
	⚠ AVERTISSEMENT GLISSANT LORSQU'IL EST MOUILLÉ OU GLACÉ Soyez prudent lorsque vous conduisez sur des rampes d'accès mouillées ou verglacées et les plateformes. NE PAS marcher sur des surfaces de levage humides ou glacées.

PN 5905138

H**J****K**

CALIFORNIA PROPOSITION 65 ⚠ WARNING ⚠
WARNING! This product can expose you to chemicals including styrene and vinyl chloride which are on the list of over 900 chemicals identified by the State of California to cause cancer, birth defects or reproductive harm. ALWAYS use this product in accordance with the manufacturer's instructions.
For more information, go to www.p65warnings.ca.gov . PN 5905775

**on packaging*

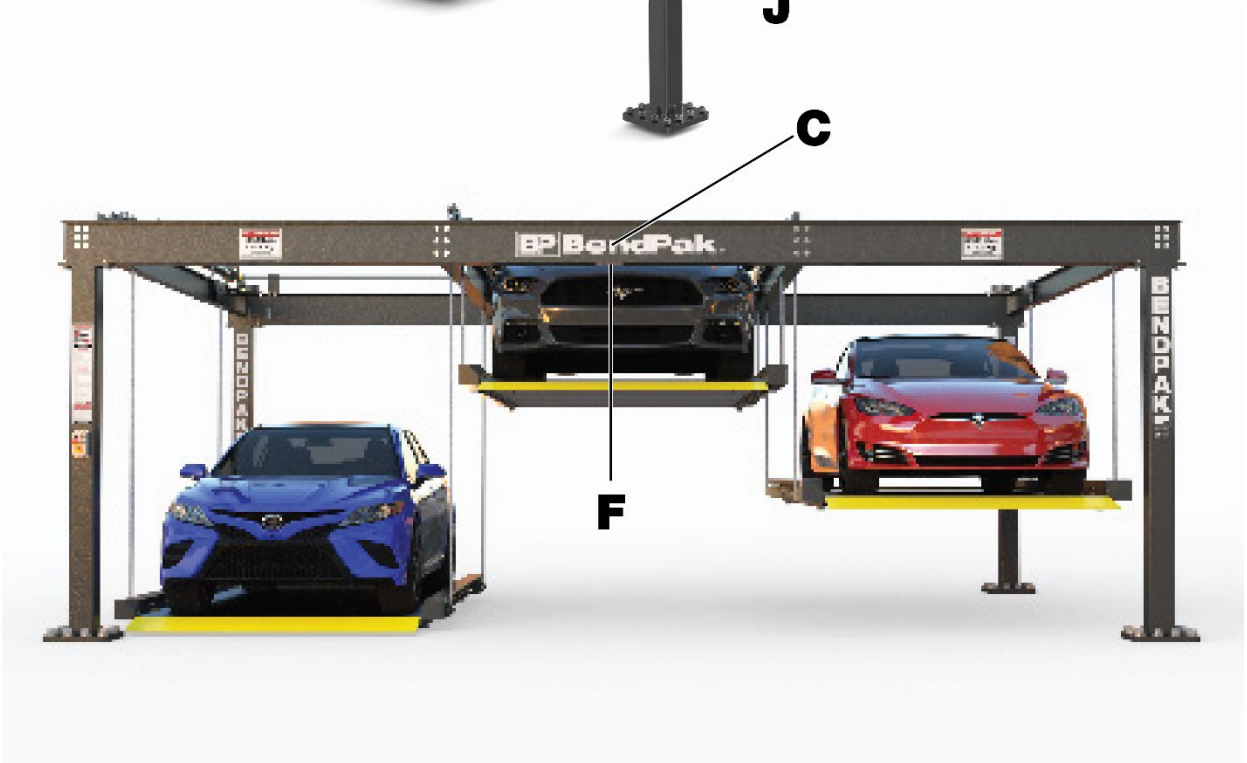
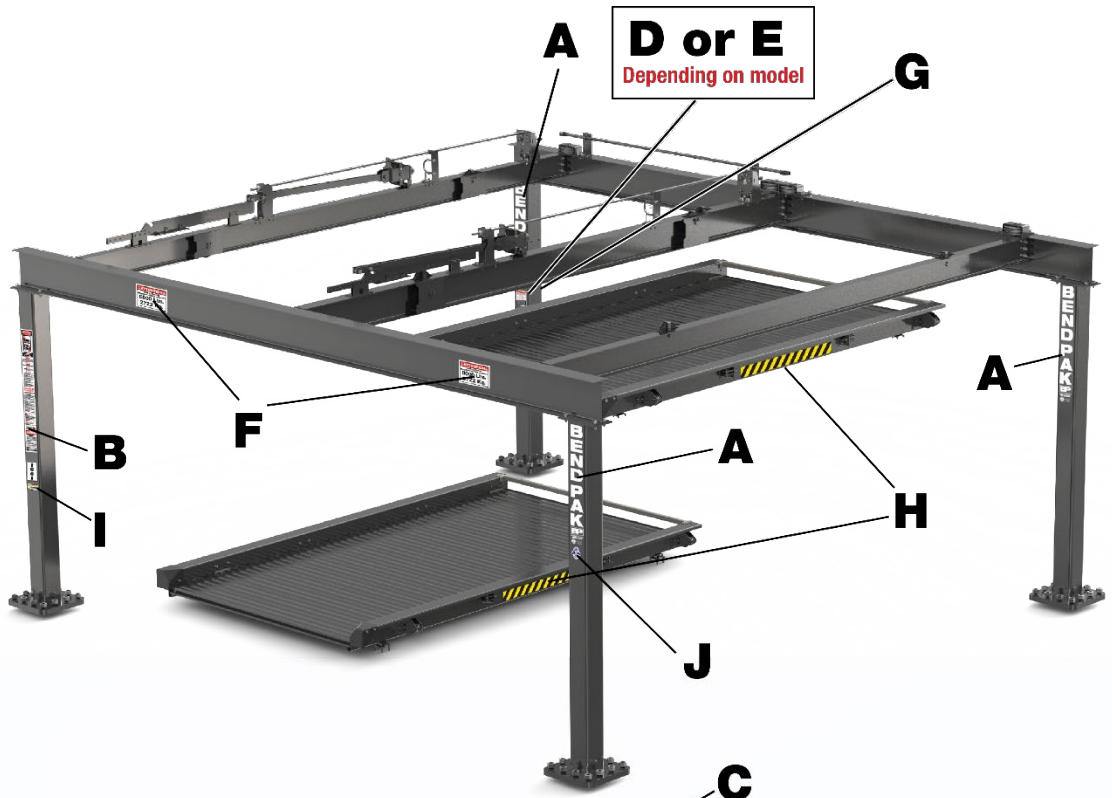

Parts Drawings

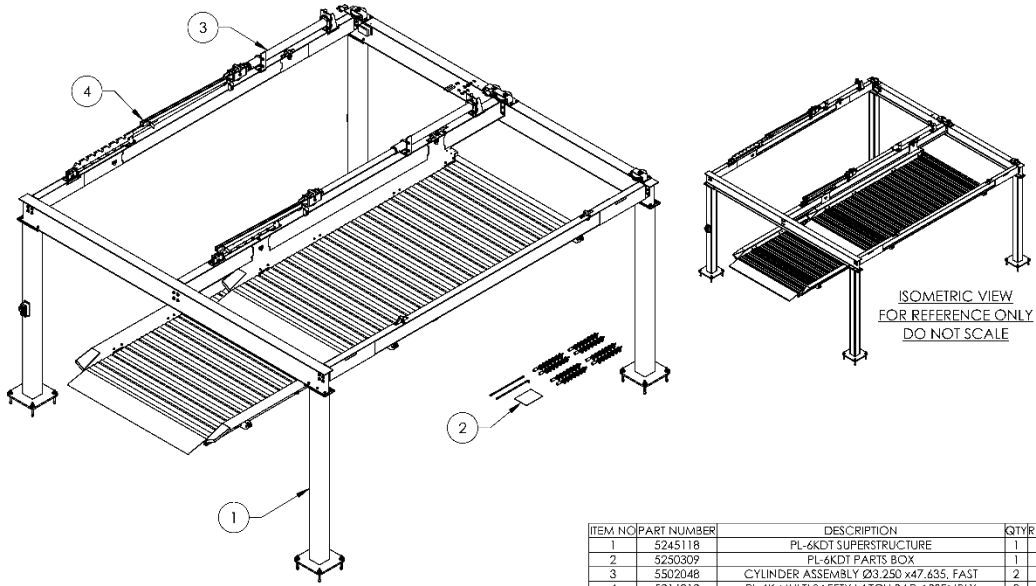

ITEM NO	PART NUMBER	DESCRIPTION	QTY	REV
1	524511B	PL-6KDT SUPERSTRUCTURE	1	B
2	5250309	PL-6KDT PARTS BOX	1	B
3	550204B	CYLINDER ASSEMBLY Ø3.250 x47.635, FAST	2	B
4	521601D	PL-6K MULTI SAFETY LATCH BAR ASSEMBLY	2	A

DRAWN: CA 10/27/2020		DATE	
CHECKED: OR 1/29/2021		DATE	
UNIVERSITY OF CALIFORNIA		THIRD ANGLE PROJECTION	
SECRETARY AND CONFIDENTIAL		TITLE: PL-6KDT PRODUCTION LIFT VER B	
SEE DWG. NO. A 5260640		REV F	
SCALE: 1:50		SHEET 1 OF 3	

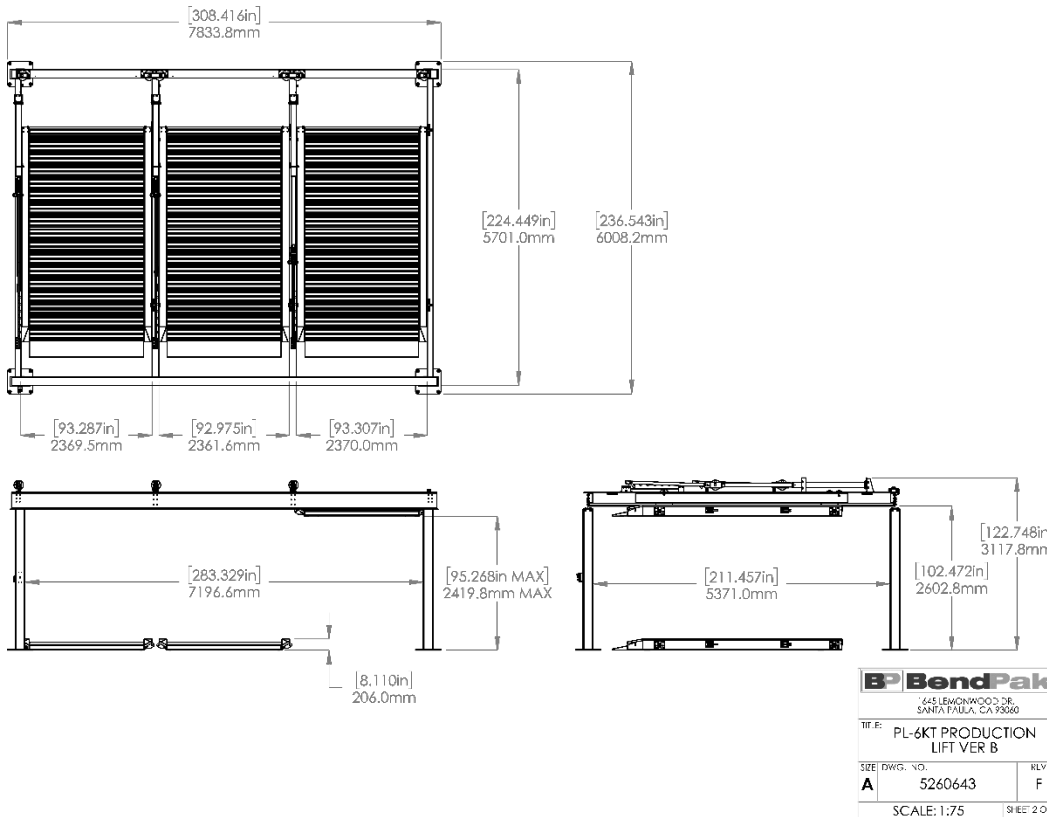

*The 102.472" value measures the fixed inside height of the Lift Structure, not the Post height.

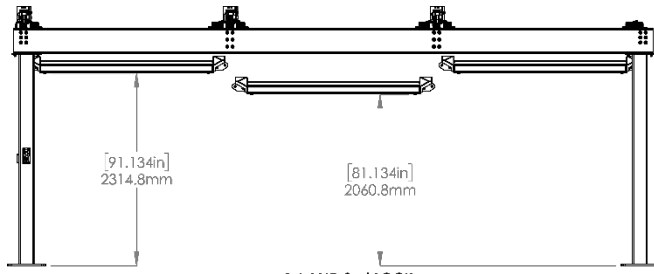

1st AND 2nd LOCK

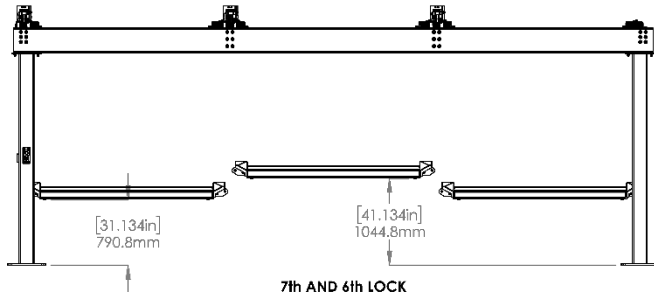

7th AND 8th LOCK

BendPak
 1645 LEMONWOOD DR.
 SANTA PAULA, CA 95060

TITLE: PL-6KT PRODUCTION LIFT VER B

SIZE: DWG. NO. A 5260643 REV. E

SCALE: 1:65 SHEET 3 OF 3

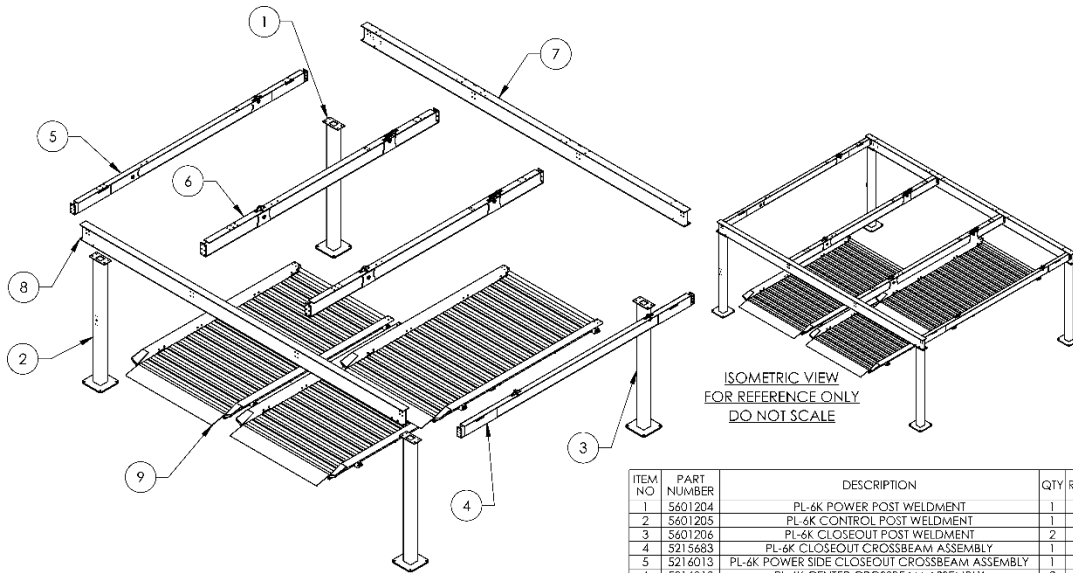

ITEM NO	PART NUMBER	DESCRIPTION	QTY	REV
1	5601204	PL-6K POWER POST WELDMENT	1	A
2	5601205	PL-6K CONTROL POST WELDMENT	1	A
3	5601206	PL-6K CLOSEOUT POST WELDMENT	2	A
4	5215683	PL-6K CLOSEOUT CROSSBEAM ASSEMBLY	1	G
5	5216013	PL-6K POWER SIDE CLOSEOUT CROSSBEAM ASSEMBLY	1	B
6	5216012	PL-6K CENTER CROSSBEAM ASSEMBLY	2	B
7	5770121	PL-6KT FRONT BEAM	1	C
8	5770122	PL-6KT REAR BEAM	1	B
9	5215684	PL-6K RAMP ASSEMBLY	3	K

NO NOT SCALE DRAWING

NAME: DATE: **BendPak**

DRAWN: CA 10/20/2020 1645 LEMONWOOD DR. SANTA PAULA, CA 95060

CHECKED: CR 08/17/2021

THIRD ANGLE PROJECTION

TITLE: PL-6KT SUPERSTRUCTURE

SIZE: DWG. NO. A 5245141 REV. B

SCALE: 1:70 SHEET 1 OF 1

PROPRIETARY AND CONFIDENTIAL
 THIS DRAWING IS THE PROPERTY OF BENDPAK INC. AND IS NOT TO BE REPRODUCED OR TRANSMITTED IN ANY FORM OR BY ANY MEANS, ELECTRONIC OR MECHANICAL, INCLUDING PHOTOCOPYING, RECORDING, OR BY ANY INFORMATION STORAGE AND RETRIEVAL SYSTEM.
 BENDPAK INC. 1645 LEMONWOOD DR. SANTA PAULA, CA 95060

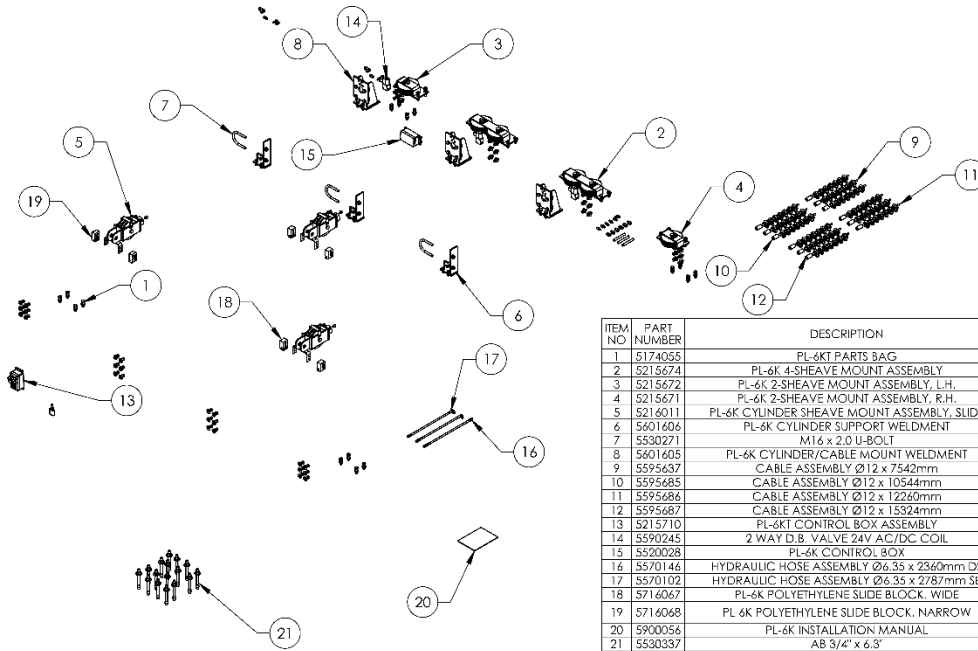

ITEM NO	PART NUMBER	DESCRIPTION	QTY	REV
1	5174055	PL-6KT PARTS BAG	1	A
2	5215674	PL-6K 4-SHEAVE MOUNT ASSEMBLY	2	C
3	5215672	PL-6K 2-SHEAVE MOUNT ASSEMBLY, L.H.	1	C
4	5215671	PL-6K 2-SHEAVE MOUNT ASSEMBLY, R.H.	1	C
5	5216011	PL-6K CYLINDER SHEAVE MOUNT ASSEMBLY, SLIDE	3	A
6	5601606	PL-6K CYLINDER SUPPORT WELDMENT	3	A
7	5530271	M16 x 2.0 U-BOLT	3	A
8	5601605	PL-6K CYLINDER/CABLE MOUNT WELDMENT	3	A
9	5595637	CABLE ASSEMBLY Ø12 x 7542mm	3	A
10	5595685	CABLE ASSEMBLY Ø12 x 10544mm	3	A
11	5595686	CABLE ASSEMBLY Ø12 x 12260mm	3	A
12	5595687	CABLE ASSEMBLY Ø12 x 13524mm	3	A
13	5215710	PL-6KT CONTROL BOX ASSEMBLY	1	C
14	5590245	2 WAY D.B. VALVE 24V AC/DC COIL	3	--
15	5520028	PL-6K CONTROL BOX	1	B
16	5570146	HYDRAULIC HOSE ASSEMBLY Ø6.35 x 2360mm DS	1	A
17	5570102	HYDRAULIC HOSE ASSEMBLY Ø6.35 x 2787mm SB	2	A
18	5716067	PL-6K POLYETHYLENE SLIDE BLOCK, WIDE	4	A
19	5716068	PL 6K POLYETHYLENE SLIDE BLOCK, NARROW	2	A
20	5900056	PL-6K INSTALLATION MANUAL	1	--
21	5530337	AB 3/4" x 6.3'	16	--

NO. OF SHEET DRAWINGS

NAME	DATE
CA	10/20/2020

BendPak
645 ELMCWOOD DR.
SANTA PAULA, CA 95060

DRAWN: CA
CHECKED: OR

THIRD ANGLE PROJECTION

TITLE: PL-6KT PARTS BOX

SIZE: DWG. NO. 5250333

REV: B

SCALE: 1:35 SHEET 1 OF 1

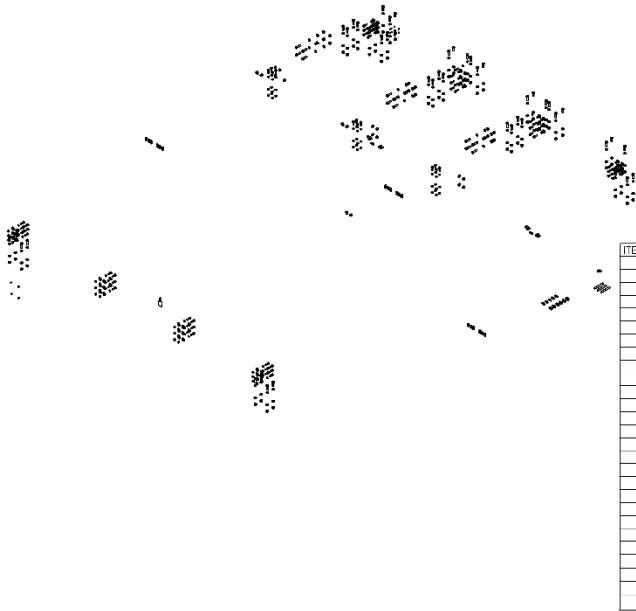

ITEM NO	PART NUMBER	DESCRIPTION	QTY	REV
1	5535008	NUT M16 x 2 NL	64	--
2	5535012	NUT M12x1.75 NL	66	--
3	5545029	WASHER M16 SL	52	--
4	5545201	WASHER M12 SPRING LOCK	61	--
5	5545025	WASHER M16 x 30mm FLAT	64	--
6	5545347	WASHER M12 FLAT WASHER	12	--
7	5535131	HHB M16 x 2.0 x 50	40	--
8	5535116	HHB M12 x 1.75 x 40	60	--
9	5535352	PHS M16 x 2.0 x 45 CL 8.8	6	--
10	5530272	HHB M16 x 2.0 x 55	12	--
11	5530029	HHB M12 x 1.75 x 25	6	--
12	5530791	PHPS M6 x 1.0 x 16mm	4	--
13	5545027	WASHER M12 x Ø37 x 3mm	48	--
14	5530018	PHPS M6 x 1 x 28mm	4	--
15	5535112	NUT M6 x 1.0	4	--
16	5550142	FIG NPL -06 ORB x -06 F NPT	6	--
17	5550100	FIG NPL -04 JIC x -06 NPT	5	--
18	5550103	FIG ELB -04 JIC -06 ORB	1	--
19	5550134	FIG TEE -06 NPT x -06 F NPT x -06 F NPT	2	--
20	5550128	FIG NPL -06 NPT x -06 NPT	2	--
21	5505026	1/2" PIPE STRAP Ø20.6mm	4	--
22	5535357	NUT M6 x 1.0 NL	4	--
23	5530756	HHB M6 x 1 x 25	4	--
24	575054	PIPE 3/8-18 NPT	3	A
25	5580012	LIQUID PTFE THREAD SEALANT 50ml	1	--
26	5530070	SHCS M10 x 1.5 x 45mm	12	--
27	5535998	NUT M10 x 1.5	12	--

NO. OF SHEET DRAWINGS

NAME	DATE
CA	10/20/2020

BendPak
645 ELMCWOOD DR.
SANTA PAULA, CA 95060

DRAWN: CA
CHECKED: OR

THIRD ANGLE PROJECTION

TITLE: PL-6KT PARTS BAG

SIZE: DWG. NO. 5174055

REV: A

SCALE: 1:45 SHEET 1 OF 2

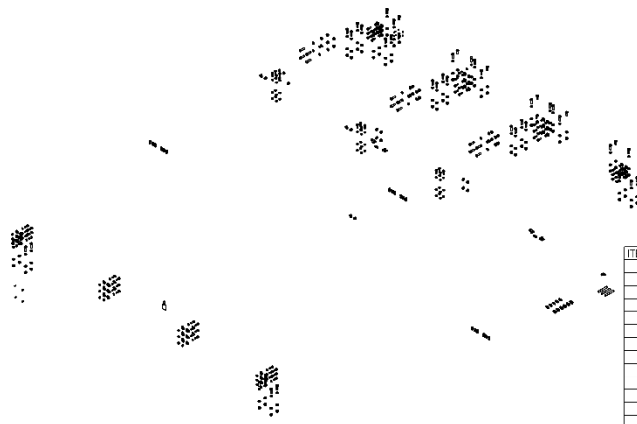

ITEM NO	PART NUMBER	DESCRIPTION	QTY	REV
1	5535008	NUT M16 x 2 NL	64	--
2	5535012	NUT M12x1.75 NL	66	--
3	5545029	WASHER M16 SL	52	--
4	5545001	WASHER M12 SPRING LOCK	61	--
5	5545025	WASHER M16 x 30mm FLAT	64	--
6	5545347	WASHER M12 FLAT WASHER	12	--
7	5535131	HHB M16 x 2.0 x 50	40	--
8	5530116	HHB M12 x 1.75 x 40	60	--
9	5530352	PHSS M16 x 2.0 x 45 CL 8.8	6	--
10	5530272	HHB M16 x 2.0 x 55	12	--
11	5530029	HHB M12 x 1.75 x 25	6	--
12	5530791	PHPS M6 x 1.0 x 16mm	4	--
13	5545027	WASHER M12 x Ø37 x 3mm	48	--
14	5530318	PHPS M6 x 1 x 25mm	4	--
15	5535112	NUT M6 x 1.0	4	--
16	5550142	FTG NPL -06 ORB x -06 F NPT	6	--
17	5550100	FTG NPL -04 JIC x -06 NPT	5	--
18	5550103	FTG ELB -04 JIC -06 ORB	1	--
19	5550136	FTG TEE -06 NPT x -06 F NPT x -06 F NPT	2	--
20	5550128	FTG NPL -06 NPT x -06 NPT	2	--
21	5505026	1/2" PIPE STRAP Ø20.4mm	4	--
22	5535357	NUT M6 x 1.0 NL	4	--
23	5530756	HHB M6 x 1 x 25	4	--
24	5750554	PIPE 3/8-18 NPT	3	A
25	5580012	LIQUID PTFE THREAD SEALANT 50ml	1	--
26	5530070	SHCS M10 x 1.5 x 45mm	12	--
27	5535998	NUT M10 x 1.5	12	--

DRAWN: CA 11/20/2020
 CHECKED: OR 11/10/2022
 NAME: DATE
 BENDPAK
 1645 LEMONWOOD DR.
 SANTA PAULA, CA 95506
 TITLE: PL-6KT PARTS BAG
 SHEET: 1 OF 2
 SCALE: 1:45

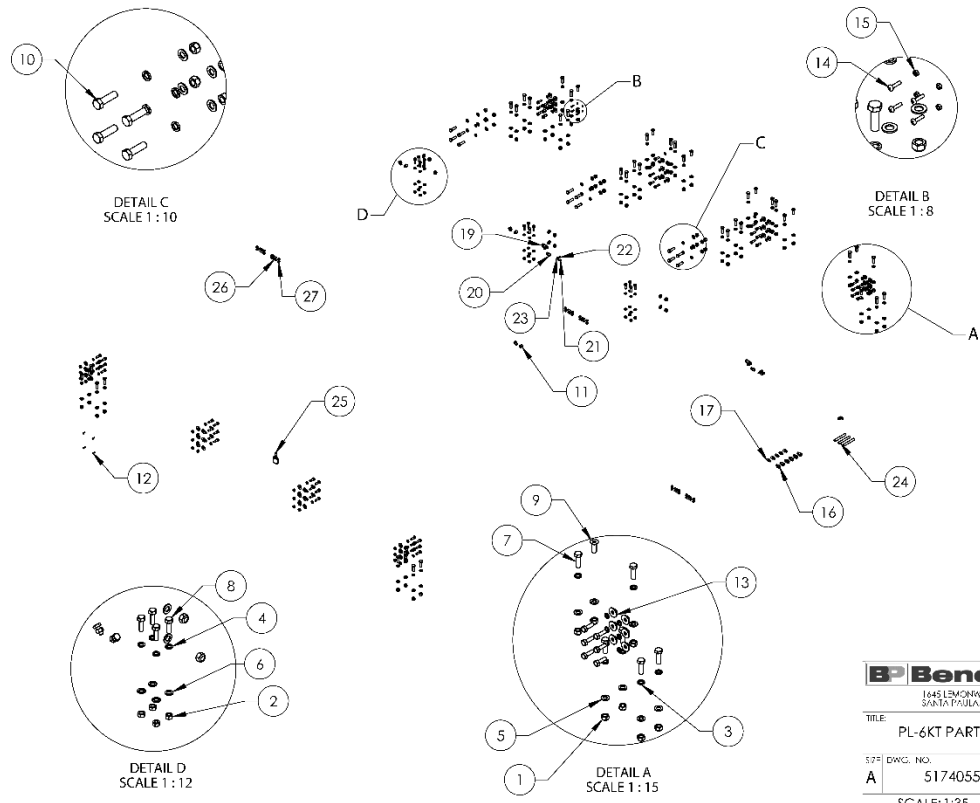

BENDPAK
 1645 LEMONWOOD DR.
 SANTA PAULA, CA 95506
 TITLE: PL-6KT PARTS BAG
 SHEET: 2 OF 2
 SCALE: 1:35

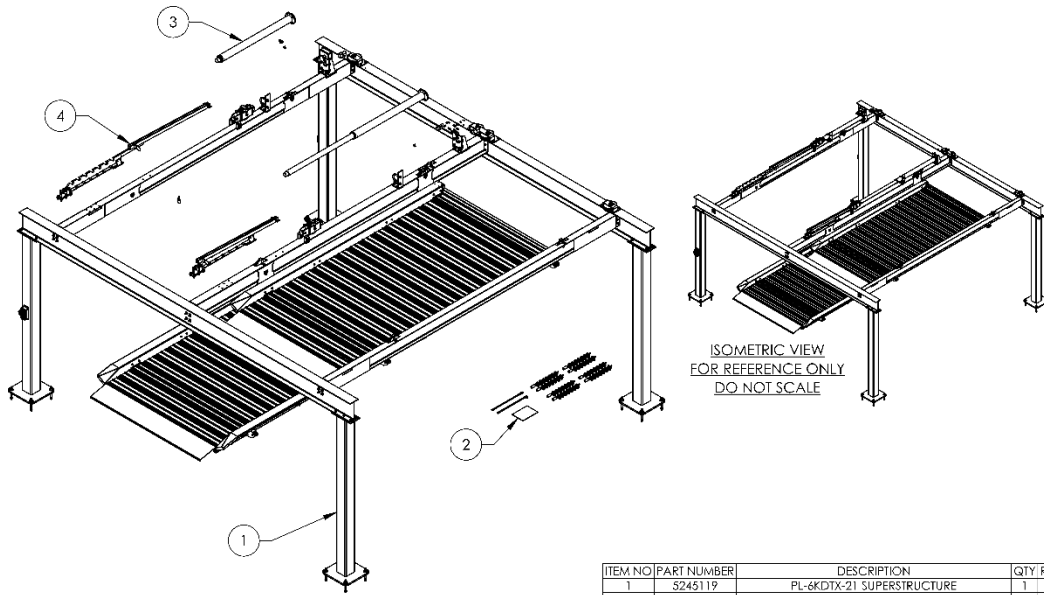

ITEM NO	PART NUMBER	DESCRIPTION	QTY	REV
1	S245119	PL-6KDTX-21 SUPERSTRUCTURE	1	B
2	S250309	PL-6KDT PARTS BOX	1	B
3	S502048	CYLINDER ASSEMBLY Ø3.250 x47.635, FAST	2	B
4	S216010	PL-6K MULTI SAFETY LATCH BAR ASSEMBLY	2	A

DO NOT SCALE DRAWING		NAME	DATE	BP BendPak 645 ELMONWOOD DR. SANTA PALLA, CA 95060
DRAWN	CA	10/27/2020		
DRAWN CHECKED		THIRD ANGLE PROJECTION		TITLE: PL-6KDTX-21 PRODUCTION LIFT VER B
SCALE		DWG. NO.	REV.	
A		5260641	F	
				SCALE: 1:55 SHEET 1 OF 3

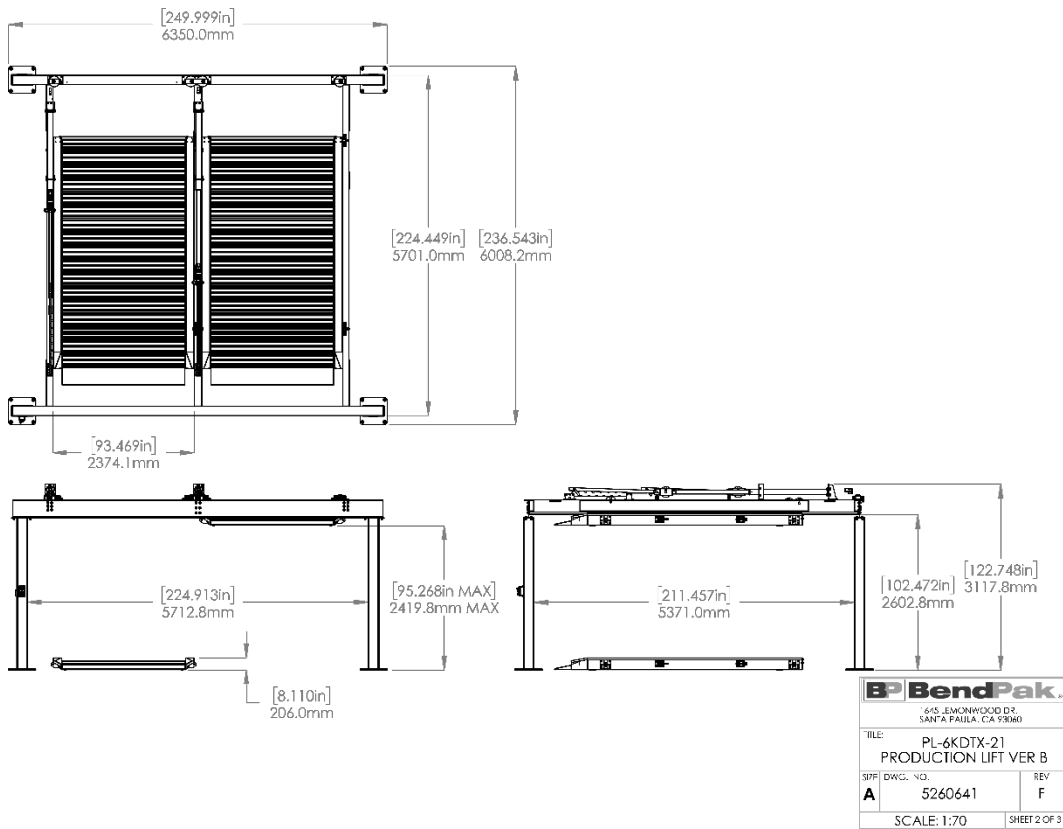

*The 102.472" value measures the fixed inside height of the Lift Structure, not the Post height.

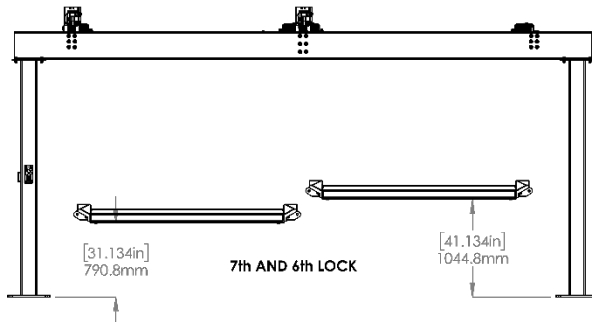
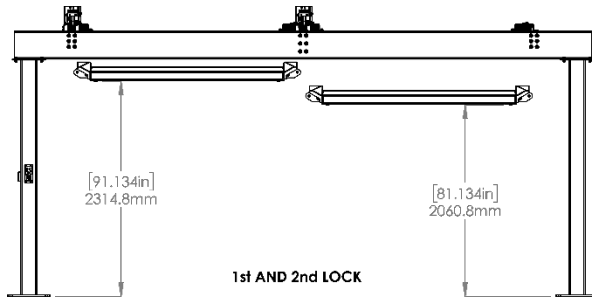

BendPak
 1445 LEWISWOOD DR.
 SANTA PAULA, CA 95060

TITLE: PL-6KDTX-21
 PRODUCTION LIFT VER B

SIZE/DWG. NO.	REV
A 5260641	E

SCALE: 1:45 SHEET 3 OF 3

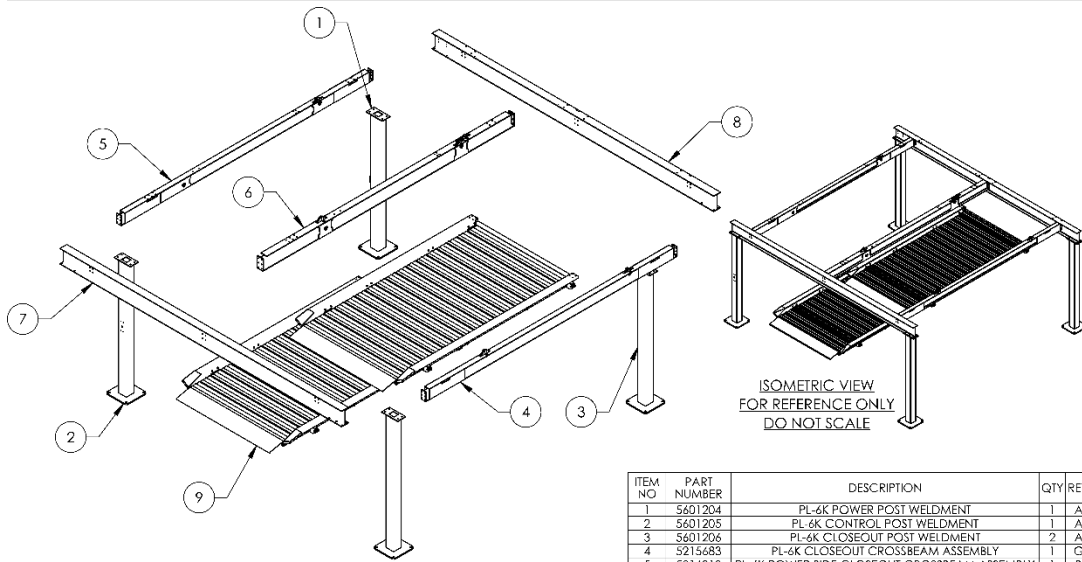

ITEM NO	PART NUMBER	DESCRIPTION	QTY	REV
1	5601204	PL-6K POWER POST WELDMENT	1	A
2	5601205	PL-6K CONTROL POST WELDMENT	1	A
3	5601206	PL-6K CLOSEOUT POST WELDMENT	2	A
4	5215683	PL-6K POWER SIDE CLOSEOUT CROSSBEAM ASSEMBLY	1	G
5	5216013	PL-6K CENTER CLOSEOUT CROSSBEAM ASSEMBLY	1	B
6	5216012	PL 6K CENTER CROSSBEAM ASSEMBLY	1	B
7	5770134	PL-6KDTX-21 REAR BEAM	1	B
8	5770133	PL-6KDTX-21 FRONT BEAM	1	C
9	5215684	PL-6K RAMP ASSEMBLY	2	K

DO NOT SCALE DRAWING

DATE	SCALE	TITLE
10/27/2020	1:65	PL-6KDTX-21 SUPERSTRUCTURE

DRW'G. NO. 5245119 REV B

SCALE: 1:65 SHEET 1 OF 1

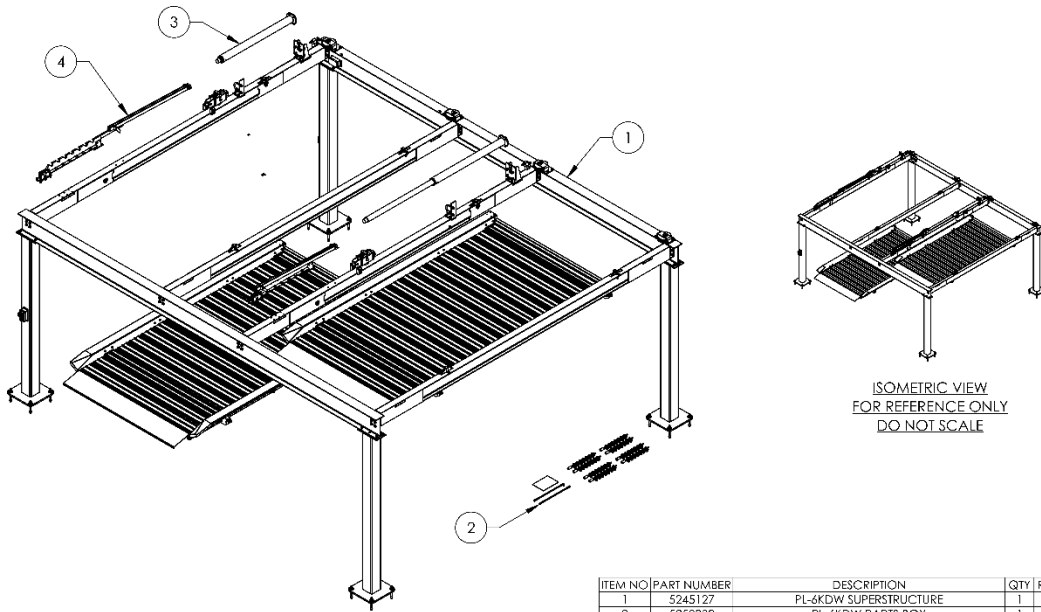

ITEM NO.	PART NUMBER	DESCRIPTION	QTY	REV
1	5245127	PL-6KDW SUPERSTRUCTURE	1	B
2	5250332	PL-6KDW PARTS BOX	1	B
3	5502048	CYLINDER ASSEMBLY Ø3.250 x47.635, FAST	2	B
4	5216010	PL-6K MULTI SAFETY LATCH BAR ASSEMBLY	2	A

DRAWN		NAME	DATE	 645 FLYINGWOOD DR. SANTA PAULA, CA 93562
CHECKED		CA	10/26/2020	
THIRD ANGLE PROJECTION			TITLE	REV
			PL-6KDW PRODUCTION LIFT VER B	F
<small>PROPRIETARY AND CONFIDENTIAL THIS INFORMATION IS UNCLASSIFIED AND PUBLIC RELEASE INFORMATION IS THE PROPERTY OF BENDPAK INC. © 2020 ALL RIGHTS RESERVED. CONTACT BENDPAK INC. FOR FURTHER INFORMATION.</small>			SCALE	SHEET
			A 5260642	1:50 1 OF 3

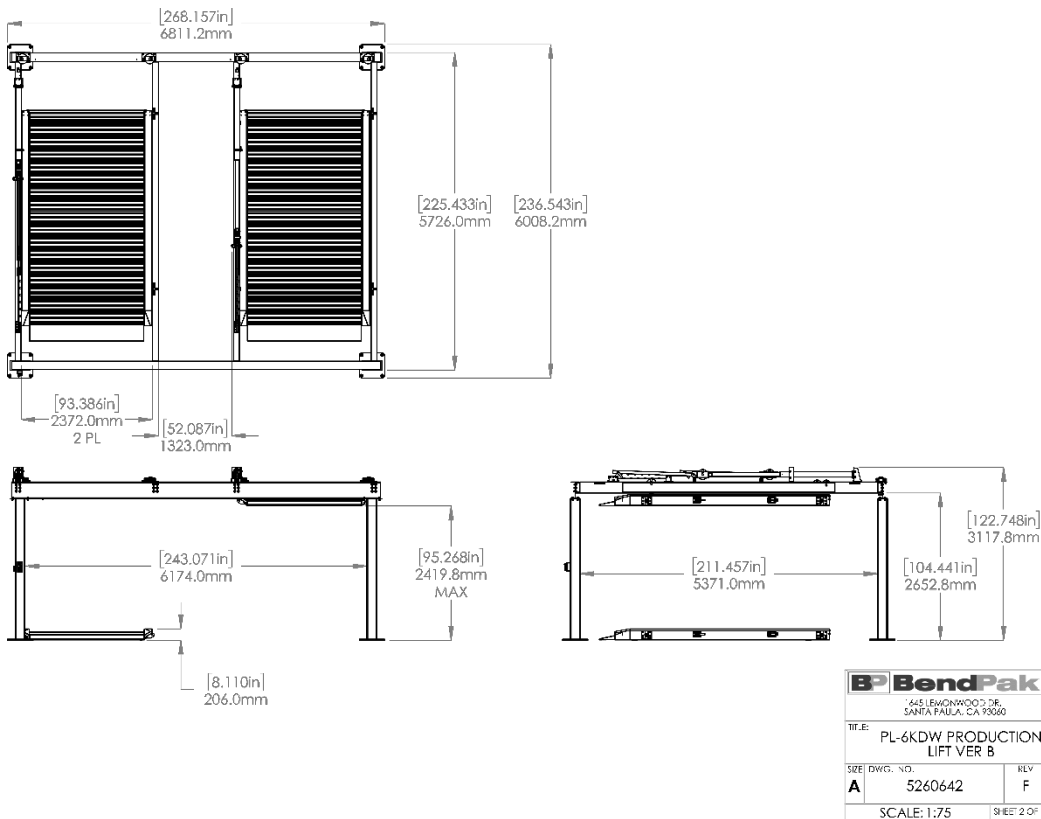

*The 102.472" value measures the fixed inside height of the Lift Structure, not the Post height.

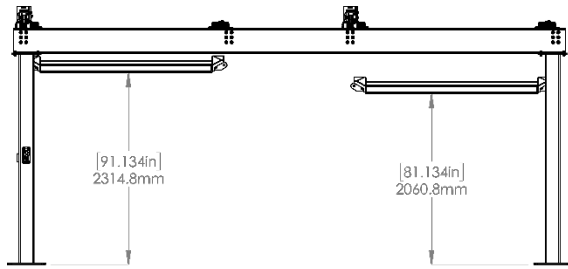

1st AND 2nd LOCK

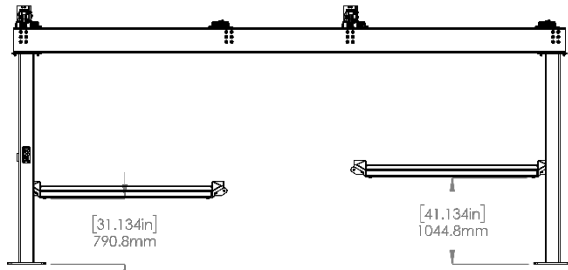

7th AND 6th LOCK

BP BendPak
 1445 LEMMONWOOD DR
 SANTA PAULA, CA 93060

TITLE: PL-6KDW PRODUCTION LIFT VER B

SIZE DWG. NO. REV
 A 5260642 E

SCALE: 1:50 \$ B L 3 0 3

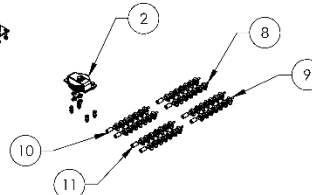
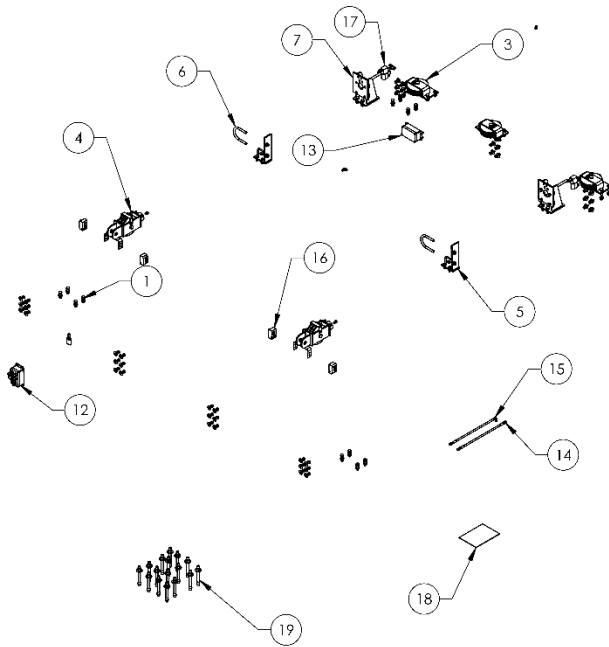

ITEM NO	PART NUMBER	DESCRIPTION	QTY	REV
1	5174054	PL-6KDW PARTS BAG	1	A
2	5215671	PL-6K 2 SHEAVE MOUNT ASSEMBLY, R.H.	2	C
3	5215672	PL-6K 2 SHEAVE MOUNT ASSEMBLY, L.H.	2	C
4	5216011	PL-6K CYLINDER SHEAVE MOUNT ASSEMBLY, SLIDE	2	A
5	5601606	PL-6K CYLINDER SUPPORT WELDMENT	2	A
6	5530271	M16 x 2.0 U-BOLT	2	A
7	5601605	PL-6K CYLINDER/CABLE MOUNT WELDMENT	2	A
8	5595637	CABLE ASSEMBLY Ø12 x 7542mm	2	A
9	5595685	CABLE ASSEMBLY Ø12 x 10544mm	2	A
10	5595686	CABLE ASSEMBLY Ø12 x 12260mm	2	A
11	5595687	CABLE ASSEMBLY Ø12 x 13324mm	2	A
12	5215711	PL-6K CONTROL BOX ASSEMBLY	1	C
13	5520028	PL-6K CONTROL BOX	1	-
14	5570146	HYDRAULIC HOSE ASSEMBLY Ø6.35 x 2360mm DS	1	A
15	5570102	HYDRAULIC HOSE ASSEMBLY Ø6.35 x 2787mm SB	1	A
16	5716068	PL-6K POLYETHYLENE SLIDE BLOCK, NARROW	4	A
17	5590245	2 WAY D.B. VALVE 24V AC/DC COIL	2	-
18	5900056	PL-6K INSTALLATION MANUAL	1	-
19	5530337	AB 3/4" x 6.3"	16	-

3D VIEW SCALE: 1:100

DRAWN: CA 10/26/2020

CHECKED:

THIRD ANGLE PROJECTION

PROPERTY AND CONFIDENTIAL INFORMATION. THIS DRAWING IS THE PROPERTY OF BENDPAK INC. AND IS NOT TO BE REPRODUCED OR TRANSMITTED IN ANY FORM OR BY ANY MEANS, ELECTRONIC OR MECHANICAL, INCLUDING PHOTOCOPYING, RECORDING, OR BY ANY INFORMATION STORAGE AND RETRIEVAL SYSTEM.

BP BendPak
 1445 LEMMONWOOD DR
 SANTA PAULA, CA 93060

TITLE: PL-6KDW PARTS BOX

SIZE DWG. NO. REV
 A 5250332 B

SCALE: 1:35 SHEET 1 OF 1

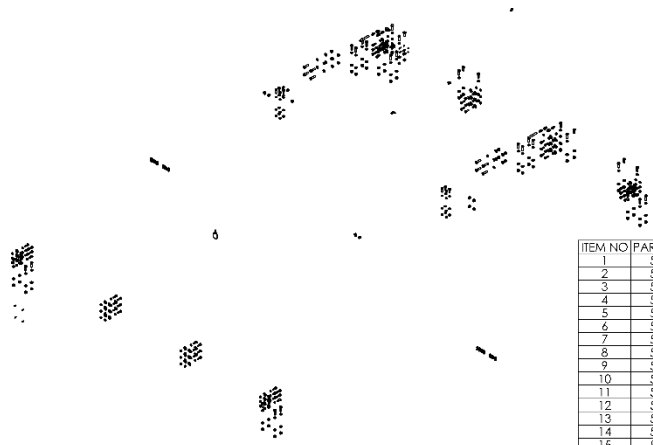

ITEM NO	PART NUMBER	DESCRIPTION	QTY	REV
1	5535008	NUT M16 x 2 NL	48	--
2	5535012	NUT M12x1.75 NL	60	--
3	5545029	WASHER M16 SL	40	--
4	5545201	WASHER, M12 SPRING LOCK	56	--
5	5545025	WASHER M16 x 30mm FLAT	48	--
6	5545347	WASHER, M12 FLAT WASHER	8	--
7	5535131	HHB M16 x 2.0 x 50	32	--
8	5530116	HHB M12 x 1.75 x 40	56	--
9	5530352	FHSS M16 x 2.0 x 45 CL 8.8	4	--
10	5530272	HHB M16 x 2.0 x 55	8	--
11	5530079	HHB M12 x 1.75 x 25	4	--
12	5530791	PHPS M6 x 1.0 x 16mm	4	--
13	5545027	WASHER M12 x Ø27 x 3mm	48	--
14	5530318	PHPS M6 x 1 x 25mm	4	--
15	5535112	NUT M6 x 1.0	4	--
16	5550142	FTG NPL -06 ORB x -06 F NPT	4	--
17	5550100	FTG NPL -04 JIC x -06 NPT	3	--
18	5550103	FTG ELB -04 JIC -06 ORB	1	--
19	5550136	FTG TEE -06 NPT x -06 F NPT x -06 F NPT	1	--
20	5550128	FTG NPL -06 NPT x -06 NPT	1	--
21	5505026	1/2" PIPE STRAP Ø20.6mm	3	--
22	5535357	NUT M6 x 1.0 NL	3	--
23	5530756	HHB M6 x 1 x 25	3	--
24	5755054	PIPE 3/8 18 NPT	2	A
25	5580012	LIQUID PTFE THREAD SEALANT 50ml	1	--
26	5545341	WASHER M10 x Ø20 FLAT	4	--
27	5530070	SHCS M10 x 1.5 x 45mm	8	--
28	5535998	NUT M10 x 1.5	8	--

DO NOT SCALE DRAWING	NAME	DATE	BP BendPak 1445 LEMONWOOD DR. SANTA PAULA, CA 95050	
DRAWN	CA	07/26/2020	TITLE: PL-6KDW PARTS BAG	
CHECKED	OR	11/20/2020	SEE DWG. NO.	REV
THIRD ANGLE PROJECTION			A	5174054
			SCALE: 1:45	SHEET 1 OF 2

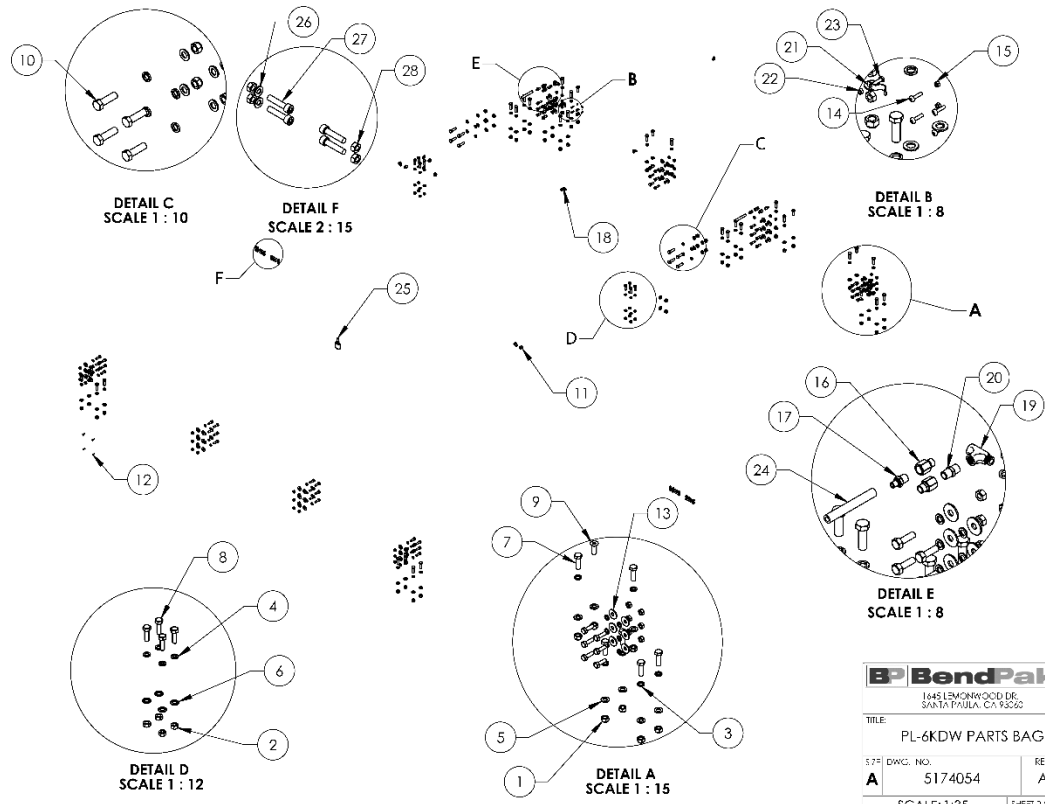

BP BendPak 1445 LEMONWOOD DR. SANTA PAULA, CA 95050	
TITLE: PL-6KDW PARTS BAG	
SEE DWG. NO.	REV
A	5174054
SCALE: 1:35	SHEET 2 OF 2

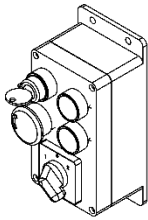

ISOMETRIC VIEW
FOR REFERENCE ONLY
DO NOT SCALE

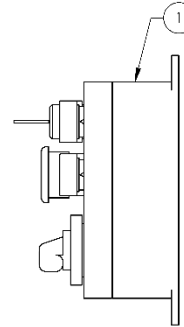
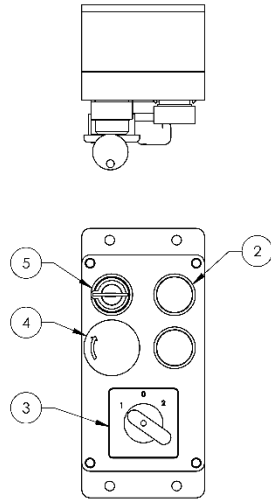

ITEM NO.	PART NUMBER	DESCRIPTION	QTY	REV
1	5520028	PL-6K CONTROL BOX	1	B
2	5520404	PUSH BUTTON 22mm METAL, BLACK 1 N.O.	2	-
3	5520029	CAM CHANGEOVER SWITCH 8 TERMINAL, 660V, 12A	1	-
4	5520401	PUSH BUTTON, 22mm, EMERGENCY	1	-
5	5520403	SELECTOR SWITCH KEY OPERATED 2 POSITION	1	-

DO NOT SCALE DRAWING	DRAWN	NAME	DATE	 1418 LILACWOOD DR. SANTA PAULA, CA 95662
	TM	TM	01/20/2017	
DIMENSIONS ARE IN MM 	CHECKED			TITLE: PL-6KD CONTROL BOX ASSEMBLY SIZE DWG. NO. A 5215711 REV C
				SCALE: 1:3 SHEET 1 OF 3

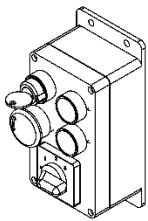

ISOMETRIC VIEW
FOR REFERENCE ONLY
DO NOT SCALE

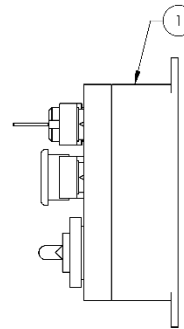
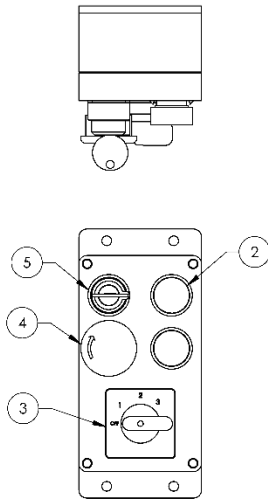

REV	DESCRIPTION	DATE	EDITED BY	ECO#
A	PRODUCTION RELEASE	01/19/2017	TM	00802
B	WAS SQUARE HOLE NOW ROUND HOLES, UPDATED BOM REVISION	05/18/2018	TM	00948
C	UPDATED WIRING, pg 3	10/19/2021	OR	01357

ITEM NO.	PART NUMBER	DESCRIPTION	QTY	REV
1	5520028	PL-6K CONTROL BOX	1	B
2	5520404	PUSH BUTTON 22mm METAL, BLACK 1 N.O.	2	-
3	5520027	CAM CHANGEOVER SWITCH 6 TERMINAL, 660V, 20A	1	-
4	5520401	PUSH BUTTON, 22mm, EMERGENCY	1	-
5	5520403	SELECTOR SWITCH KEY OPERATED 2 POSITION	1	-

DO NOT SCALE DRAWING	DRAWN	NAME	DATE	 1418 LILACWOOD DR. SANTA PAULA, CA 95662
	TM	TM	01/19/2017	
DIMENSIONS ARE IN MM 	CHECKED			TITLE: PL-6KT CONTROL BOX ASSEMBLY SIZE DWG. NO. A 5215710 REV C
				SCALE: 1:3 SHEET 1 OF 3

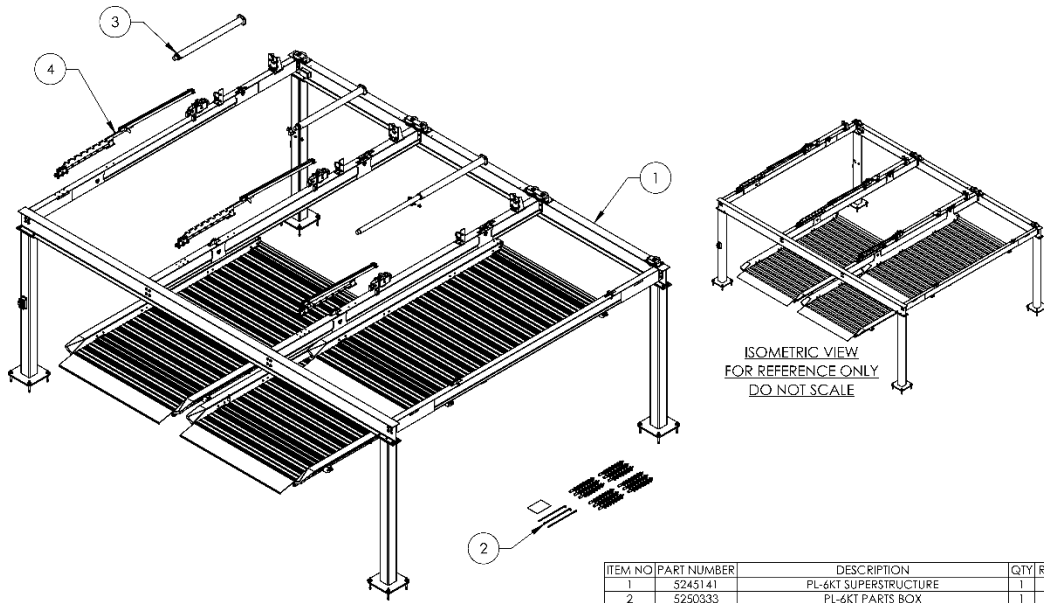

ISOMETRIC VIEW
FOR REFERENCE ONLY
DO NOT SCALE

ITEM NO	PART NUMBER	DESCRIPTION	QTY	REV
1	5245141	PL-6KT SUPERSTRUCTURE	1	B
2	5250333	PL-6KT PARTS BOX	1	B
3	5502048	CYLINDER ASSEMBLY Ø3.250 x47.635, FAST	3	B
4	5216010	PL-6K MULTI SAFETY LATCH BAR ASSEMBLY	3	A

JOHN SCALIZI DRAWING		NAME	DATE	BP BendPak 1645 LEMONWOOD DR. SANTA PAULA, CA 93060
DRAWN	CA	10/20/2020		
DIMENSIONS ARE IN MM		CHECKED		
THIRD ANGLE PROJECTION		TITLE: PL-6KT PRODUCTION LIFT VER B		
		SHEET	DWG. NO.	REV
<small>PROPRIETARY AND CONFIDENTIAL THIS DRAWING OR ANY INFORMATION CONTAINED HEREIN IS THE PROPERTY OF BENDPAK INC. AND IS TO BE KEPT IN STRICTLY CONFIDENTIAL. ANY UNAUTHORIZED REPRODUCTION OR DISSEMINATION OF THIS INFORMATION TO ANY OTHER PARTY WITHOUT THE WRITTEN PERMISSION OF BENDPAK INC. IS STRICTLY PROHIBITED.</small>		A	5260643	F
		SCALE: 1:60		SHEET 1 OF 3

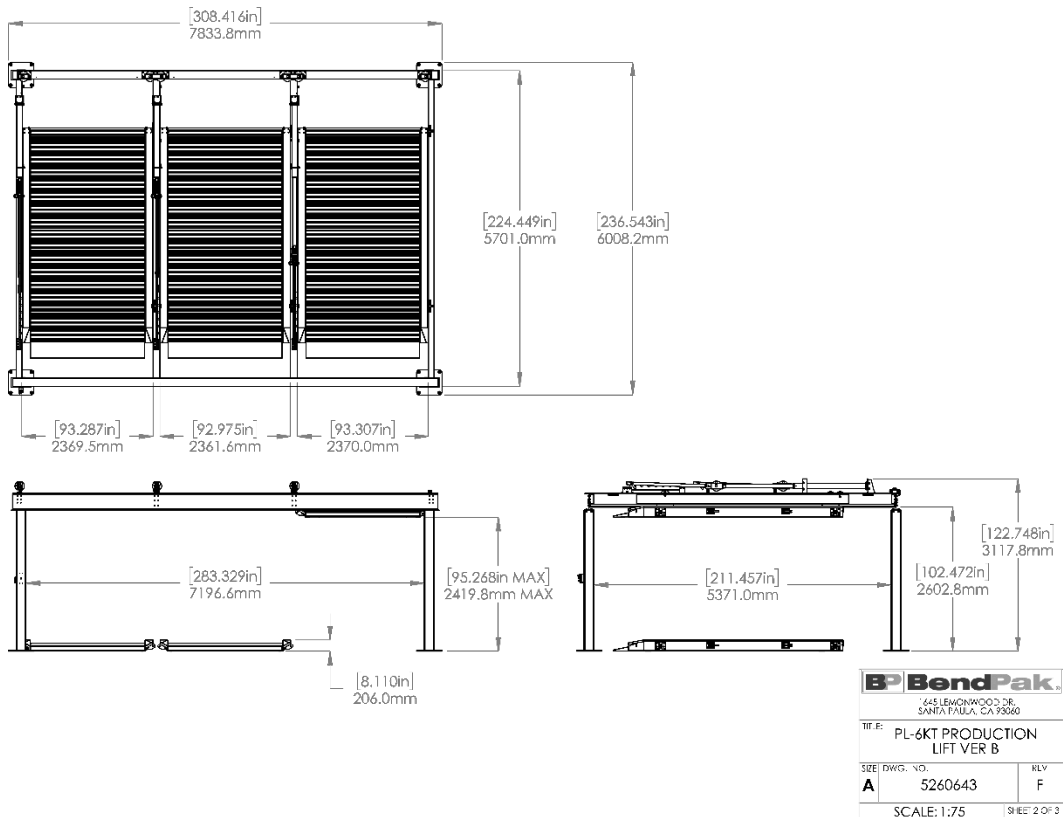

*The 102.472" value measures the fixed inside height of the Lift Structure, not the Post height.

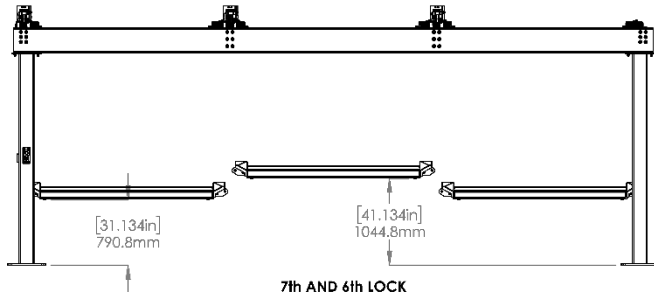
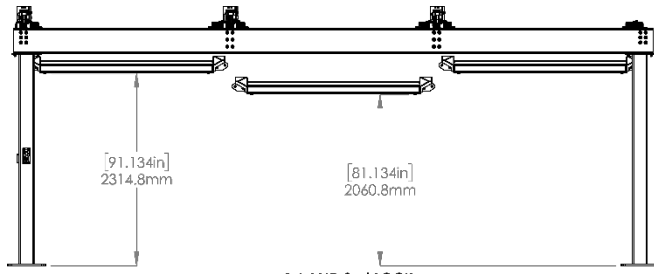

BP BendPak
1645 LEMCKE WOOD DR.
SANTA YULIA, CA 95060

TITLE: PL-6KT PRODUCTION
LIFT VER B

SIZE DWG. NO. REV

A 5260643 E

SCALE: 1:65 SHEET 3 OF 3

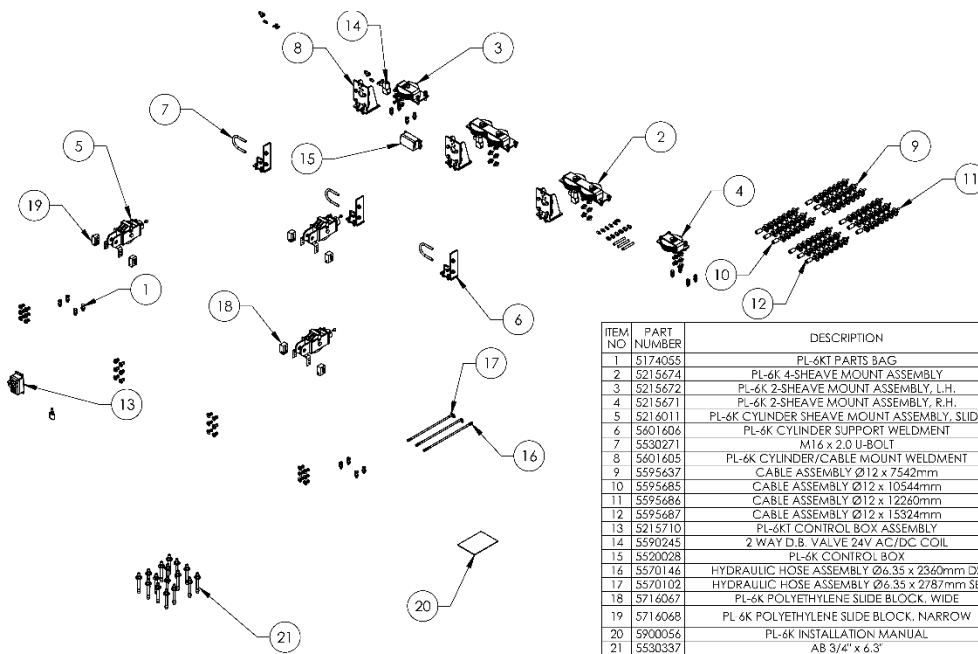

ITEM NO.	PART NUMBER	DESCRIPTION	QTY	REV
1	5174055	PL-6KT PARTS BAG	1	A
2	5215674	PL-6K 4-SHEAVE MOUNT ASSEMBLY	2	C
3	5215672	PL-6K 2-SHEAVE MOUNT ASSEMBLY, L.H.	1	C
4	5215671	PL-6K 2-SHEAVE MOUNT ASSEMBLY, R.H.	1	C
5	5216011	PL-6K CYLINDER SHEAVE MOUNT ASSEMBLY, SLIDE	3	A
6	5601606	PL-6K CYLINDER SUPPORT WELDMENT	3	A
7	5530271	M16 x 2.0 U-BOLT	3	A
8	5601605	PL-6K CYLINDER/CABLE MOUNT WELDMENT	3	A
9	5595637	CABLE ASSEMBLY Ø12 x 7542mm	3	A
10	5595685	CABLE ASSEMBLY Ø12 x 10544mm	3	A
11	5595686	CABLE ASSEMBLY Ø12 x 12260mm	3	A
12	5595687	CABLE ASSEMBLY Ø12 x 15324mm	3	A
13	5215710	PL-6KT CONTROL BOX ASSEMBLY	1	C
14	5590245	2 WAY D.B. VALVE 24V AC/DC COIL	3	--
15	5520028	PL-6K CONTROL BOX	1	B
16	5570146	HYDRAULIC HOSE ASSEMBLY Ø6.35 x 2360mm DS	1	A
17	5570102	HYDRAULIC HOSE ASSEMBLY Ø6.35 x 2787mm SB	2	A
18	5716067	PL-6K POLYETHYLENE SLIDE BLOCK, WIDE	4	A
19	5716068	PL 6K POLYETHYLENE SLIDE BLOCK, NARROW	2	A
20	5900056	PL-6K INSTALLATION MANUAL	1	--
21	5530337	AB 3/4" x 6.3"	16	--

DESIGNED BY: CA	NAME: CA	DATE: 10/20/2020	BP BendPak 1645 LEMCKE WOOD DR. SANTA YULIA, CA 95060
DRAWN BY: CA	NAME: CA	DATE: 10/20/2020	
CHECKED BY:	NAME:	DATE:	TITLE: PL-6KT PARTS BOX
DIMENSIONS ARE IN MM			PROJECTION: THIRD ANGLE PROJECTION
SCALE: 1:35			SHEET 1 OF 1



ITEM NO	PART NUMBER	DESCRIPTION	QTY	REV
1	553008	NUT M16 x 2 NL	64	--
2	553012	NUT M12x1.75 NL	66	--
3	5545029	WASHER M16 S1	52	--
4	5545021	WASHER M12 SPRING LOCK	61	--
5	5545025	WASHER M16 x 30mm FLAT	64	--
6	5545347	WASHER M12 FLAT WASHER	12	--
7	5535131	HHB M16 x 2.0 x 50	40	--
8	5530116	HHB M12 x 1.75 x 40	60	--
9	5530352	FHSS M16 x 2.0 x 45 CL 3.8	6	--
10	5530272	HHB M16 x 2.0 x 55	12	--
11	5530029	HHB M12 x 1.75 x 25	6	--
12	5530791	PHPS M6 x 1.0 x 16mm	4	--
13	5545027	WASHER M12 x Ø37 x 3mm	48	--
14	5530318	PHPS M6 x 1 x 25mm	4	--
15	5535112	NUT M6 x 1.0	4	--
16	5550142	FTG NPL -06 ORB x -06 F NPT	6	--
17	5550100	FTG NPL -04 JIC x -06 NPT	5	--
18	5550103	FTG ELB -04 JIC -06 ORB	1	--
19	5550136	FTG TEE -06 NPT x -06 F NPT x -06 F NPT	2	--
20	5550128	FTG NPL -06 NPT x -06 NPT	2	--
21	5505024	1/2" PIPE STRAP Ø20 6mm	4	--
22	5535357	NUT M6 x 1.0 NL	4	--
23	5530756	HHB M6 x 1 x 25	4	--
24	5755054	PIPE 3/8 18 NPT	3	A
25	5980012	LIQUID PIPE THREAD SEALANT 50ml	1	--
26	5530070	SHCS M10 x 1.5 x 45mm	12	--
27	5535998	NUT M10 x 1.5	12	--

NAME	DATE
DRAWN CA	10/20/2020
CHECKED CR	11/12/2020

BendPak
 1445 LEMONWOOD DR.
 SANTA PAULA, CA 93060

TITLE: PL-6KT PARTS BAG
 DWG. NO. 5174055
 REV A

SCALE: 1:45 § REF: 1 OF 2

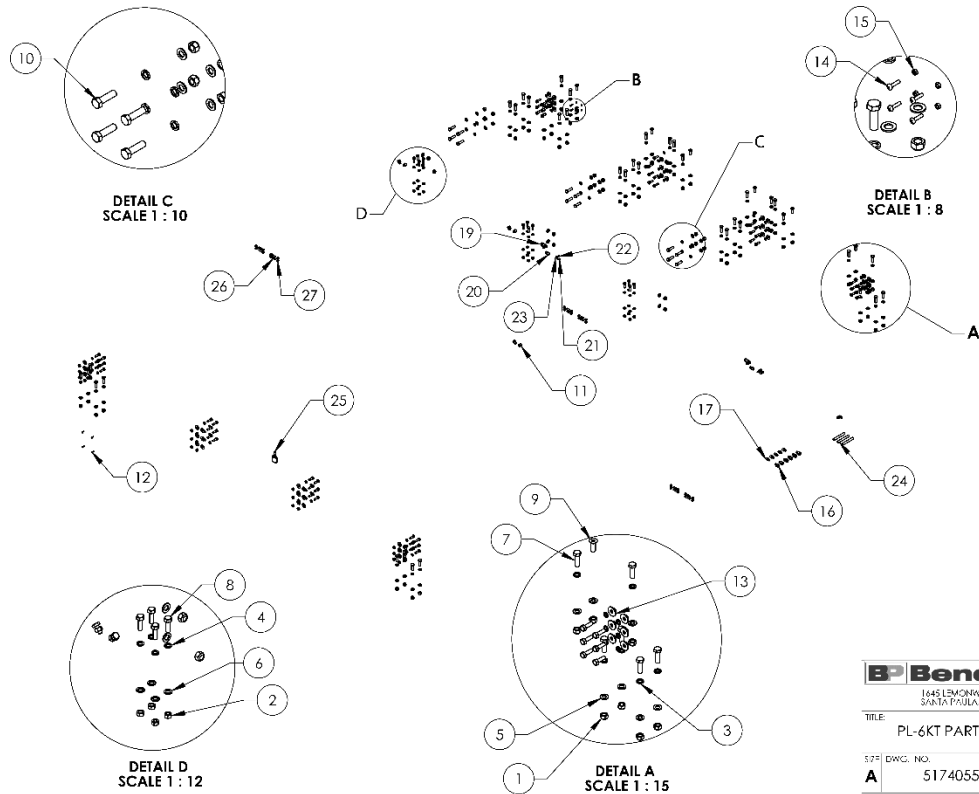

BendPak
 1445 LEMONWOOD DR.
 SANTA PAULA, CA 93060

TITLE: PL-6KT PARTS BAG
 DWG. NO. 5174055
 REV A

SCALE: 1:35 § REF: 2 OF 2

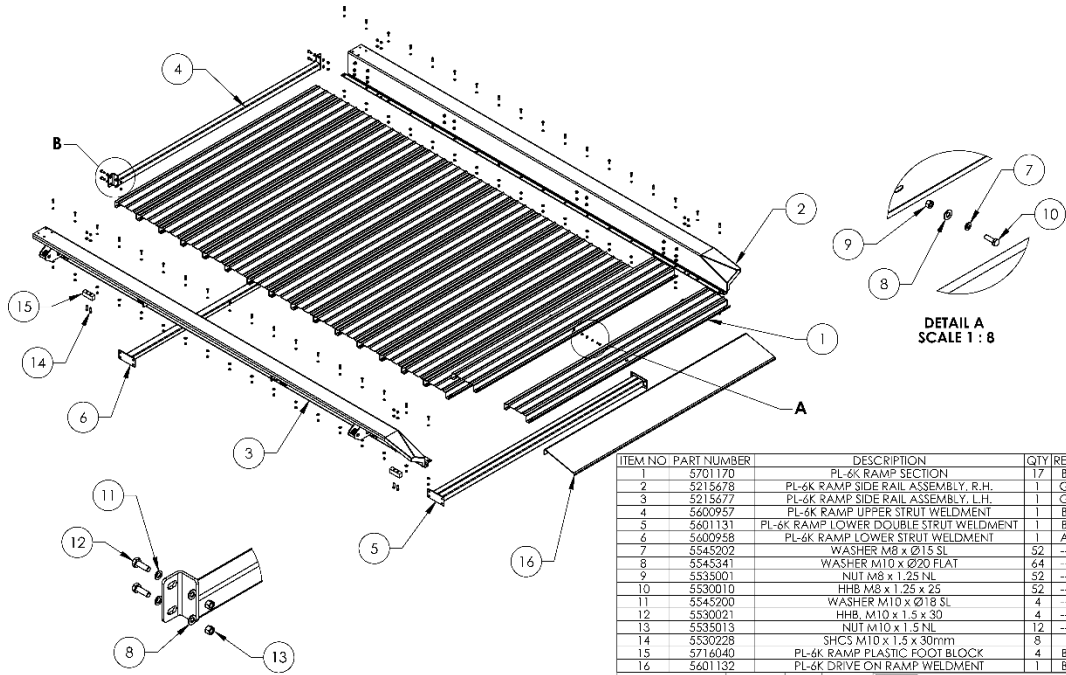

ITEM NO.	PART NUMBER	DESCRIPTION	QTY	REV
1	5701170	PL-6K RAMP SECTION	17	B
2	5215678	PL-6K RAMP SIDE RAIL ASSEMBLY, R.H.	1	G
3	5215677	PL-6K RAMP SIDE RAIL ASSEMBLY, L.H.	1	G
4	5600957	PL-6K RAMP UPPER STRUT WELDMENT	1	B
5	5601131	PL-6K RAMP LOWER DOUBLE STRUT WELDMENT	1	B
6	5600958	PL-6K RAMP LOWER STRUT WELDMENT	1	A
7	5545202	WASHER M8 x Ø15 SL	52	--
8	5545341	WASHER M10 x Ø20 FLAT	64	--
9	5535001	NUT M8 x 1.25 NL	52	--
10	5530010	HHB M8 x 1.25 x 25	52	--
11	5545200	WASHER M10 x Ø18 SL	4	--
12	5530021	HHB, M10 x 1.5 x 30	4	--
13	5535013	NUT M10 x 1.5 NL	12	--
14	5530228	SHCS M10 x 1.5 x 30mm	8	--
15	5716040	PL-6K RAMP PLASTIC FOOT BLOCK	4	B
16	5601132	PL-6K DRIVE ON RAMP WELDMENT	1	B

3/0 1/0" SCALE DRAWING	NAME	DATE	 1645 LAKONWOOD DR SANIA VALLE, CA 93060
DRAWING MADE IN USA	DRAWN: IM	02/12/2013	
	CHECKED: CA	04/05/2019	
	THIRD ANGLE PROJECTION		
	<small>PROPRIETARY AND CONFIDENTIAL THIS DRAWING IS THE PROPERTY OF BENDPAK, INC. ALL RIGHTS RESERVED. NO PART OF THIS DRAWING IS TO BE REPRODUCED OR TRANSMITTED IN ANY FORM OR BY ANY MEANS, ELECTRONIC OR MECHANICAL, WITHOUT PERMISSION IN WRITING FROM BENDPAK, INC.</small>		
	TITLE: PL-6K RAMP ASSEMBLY		
	SIZE: DWG. NO. A	5215684	REV: K
	SCALE: 1:30		SHEET 1 OF 2

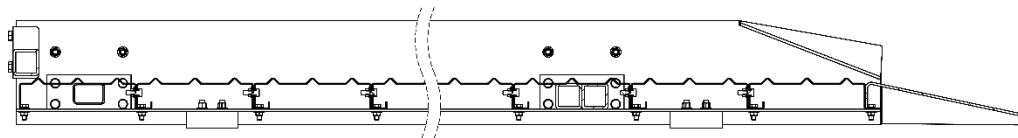
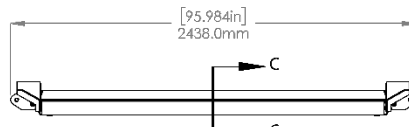
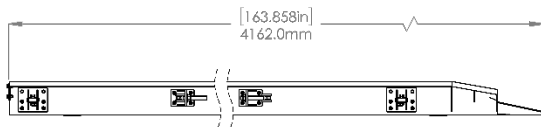

SECTION C-C
SCALE 1 : 8

 1645 LAKONWOOD DR SANIA VALLE, CA 93060	
TITLE: PL-6K RAMP ASSEMBLY	
SIZE: DWG. NO. A	5215684
REV: K	
SCALE: 1:25	
SHEET 2 OF 2	

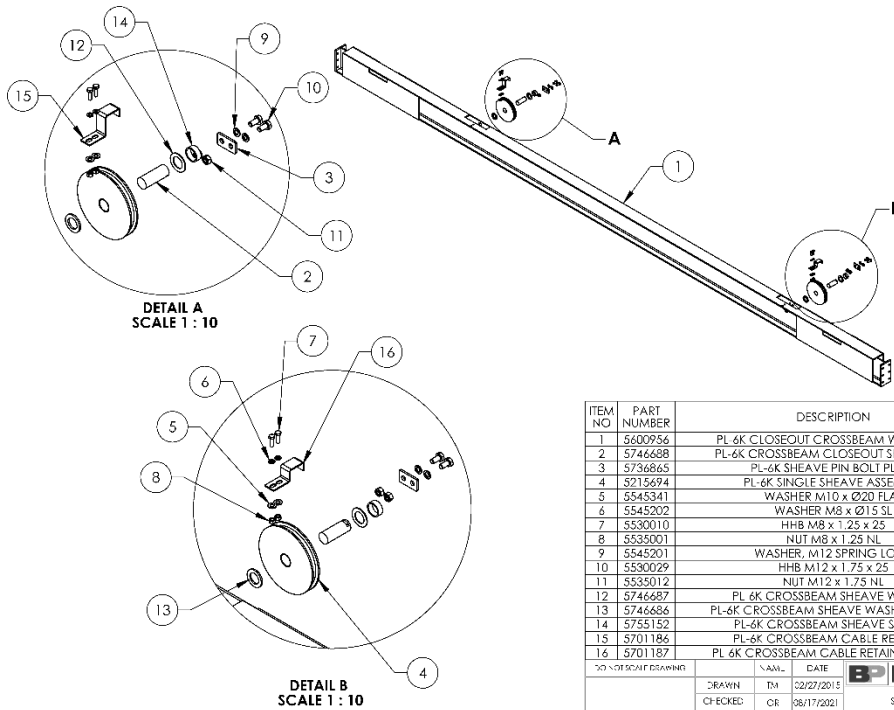

ITEM NO	PART NUMBER	DESCRIPTION	QTY	REV
1	5600956	PL 6K CLOSEOUT CROSSBEAM WELDMENT	1	E
2	5746688	PL-6K CROSSBEAM CLOSEOUT SHEAVE PIN	2	B
3	5736865	PL-6K SHEAVE PIN BOLT PLATE	2	A
4	5215694	PL-6K SINGLE SHEAVE ASSEMBLY	2	A
5	5545341	WASHER M10 x Ø20 FLAT	4	--
6	5545202	WASHER M8 x Ø15 SL	4	--
7	5530010	HHB M8 x 1.25 x 25	4	--
8	5535001	NUT M8 x 1.25 NL	4	--
9	5545201	WASHER, M12 SPRING LOCK	4	--
10	5530029	HHB M12 x 1.75 x 25	4	--
11	5535012	NUT M12 x 1.75 NL	4	--
12	5746687	PL 6K CROSSBEAM SHEAVE WASHER	2	A
13	5746686	PL-6K CROSSBEAM SHEAVE WASHER, LARGE	2	A
14	5755152	PL-6K CROSSBEAM SHEAVE SPACER	2	A
15	5701186	PL-6K CROSSBEAM CABLE RETAINER	1	A
16	5701187	PL 6K CROSSBEAM CABLE RETAINER, SMALL	1	A

NO. OF SCALE DRAWING	NAME	DATE	BendPak 6645 FAUCIWOOD DR. SANTA PAULA, CA 95666
DRAWN	TM	02/27/2015	
CHECKED	CE	08/17/2021	PL-6K CLOSEOUT CROSSBEAM ASSEMBLY SIZE DWG. NO. REV A 5215683 G SCALE: 1:30 SHEET 1 OF 1
DM'S/MS ASY. & MFG	THIRD ANGLE PROJECTION		

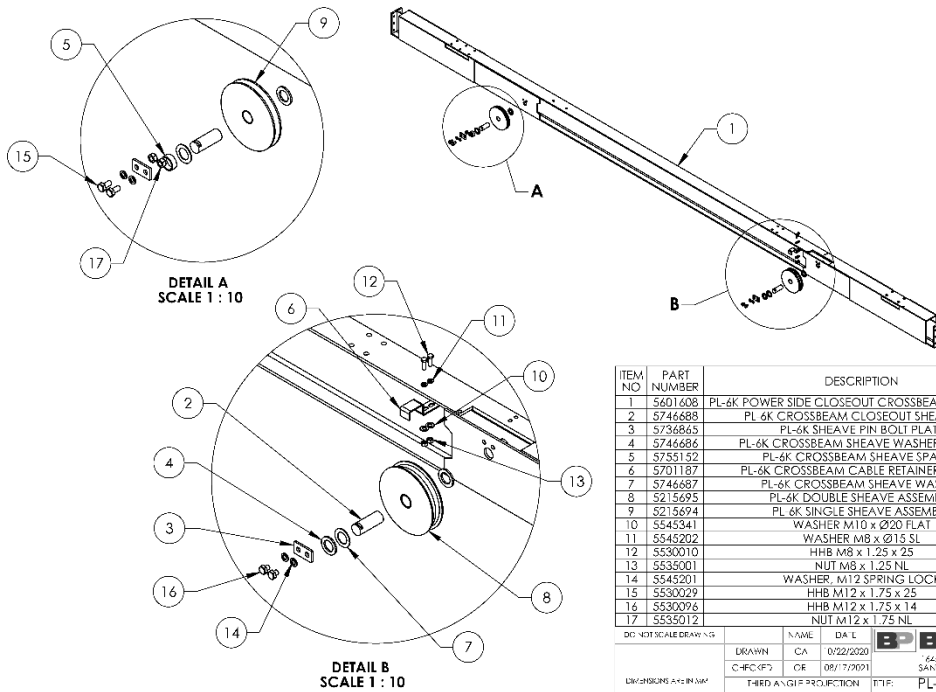

ITEM NO	PART NUMBER	DESCRIPTION	QTY	REV
1	5601608	PL-6K POWER SIDE CLOSEOUT CROSSBEAM WELDMENT	1	A
2	5746688	PL 6K CROSSBEAM CLOSEOUT SHEAVE PIN	2	B
3	5736865	PL-6K SHEAVE PIN BOLT PLATE	2	A
4	5746686	PL-6K CROSSBEAM SHEAVE WASHER, LARGE	3	A
5	5755152	PL-6K CROSSBEAM SHEAVE SPACER	1	A
6	5701187	PL-6K CROSSBEAM CABLE RETAINER, SMALL	1	A
7	5746687	PL-6K CROSSBEAM SHEAVE WASHER	2	A
8	5215695	PL-6K DOUBLE SHEAVE ASSEMBLY	1	B
9	5215694	PL 6K SINGLE SHEAVE ASSEMBLY	1	A
10	5545341	WASHER M10 x Ø20 FLAT	2	--
11	5545202	WASHER M8 x Ø15 SL	2	--
12	5530010	HHB M8 x 1.25 x 25	2	--
13	5535001	NUT M8 x 1.25 NL	2	--
14	5545201	WASHER, M12 SPRING LOCK	4	--
15	5530029	HHB M12 x 1.75 x 25	2	--
16	5530026	HHB M12 x 1.75 x 14	2	--
17	5535012	NUT M12 x 1.75 NL	2	--

NO. OF SCALE DRAWING	NAME	DATE	BendPak 6645 FAUCIWOOD DR. SANTA PAULA, CA 95666
DRAWN	CA	07/22/2020	
CHECKED	CF	08/17/2021	PL-6K POWER SIDE CLOSEOUT CROSSBEAM ASSEMBLY SIZE DWG. NO. REV A 5216013 B SCALE: 1:30 SHEET 1 OF 1
DM'S/MS ASY. & MFG	THIRD ANGLE PROJECTION		

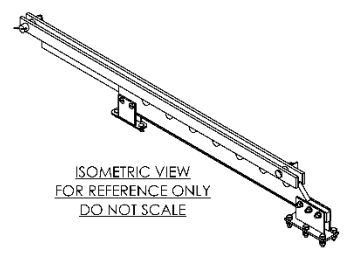
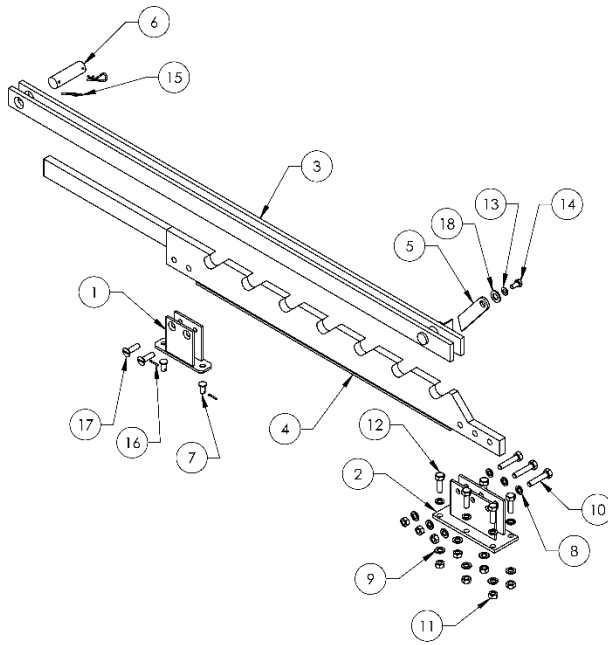

ITEM NO	PART NUMBER	DESCRIPTION	QTY	REV
1	5600967	PL-6K SAFETY BAR BRACKET WELDMENT	1	A
2	5600966	PL-6K SAFETY BAR REAR BRACKET WELDMENT	1	A
3	5601602	PL-6K MULTI SAFETY LATCH BAR WELDMENT	1	A
4	5601603	PL-6K MULTI SAFETY LATCH TRIP PLATE WELDMENT	1	A
5	5736871	PL-6K SAFETY LATCH	1	A
6	5746367	PL-6K SAFETY LATCH BAR PIN	1	A
7	5746171	PL-6K SAFETY BRACKET PIN	2	A
8	5545201	WASHER, M12 SPRINGS LOCK	9	--
9	5545347	WASHER, M12 FLAT WASHER	9	--
10	5530323	HHB, M12 x 1.75 x 60 CL 10.9	3	--
11	5535012	NUT M12x1.75 NL	9	--
12	5530116	HHB, M10 x 1.75 x 40	6	--
13	5545341	WASHER M10 x Ø20 FLAT	1	--
14	5530267	HHB, M10 x 1.5 x 20	1	--
15	5505020	HAIR PIN #238, 0.125" x 2.778" L ZPL	2	--
16	5505006	COTTER PIN Ø3.2 x 20mm	2	--
17	5530273	FHS M12 x 1.75 x 40	2	--
18	5545025	WASHER M16 x 30mm FLAT	1	--

DO NOT SCALE DRAWING	NAME	DATE	BendPak 4621 BAYWOOD DR. SANTA PAULA, CA 95060	
	DRAWN	CA 10/19/2020		
	CHECKED	OR 11/10/2020		
DIMENSIONS ARE IN MILLIMETERS	THIRD ANGLE PROJECTION		TITLE: PL-6K MULTI SAFETY LATCH BAR ASSEMBLY	
	SIZE	DWG. NO.	REV	
		A	5216010	A
			SCALE: 1:10	SHEET 1 OF 1

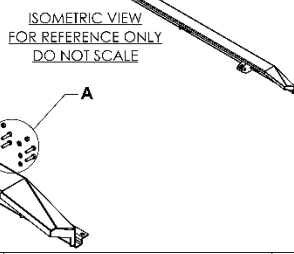
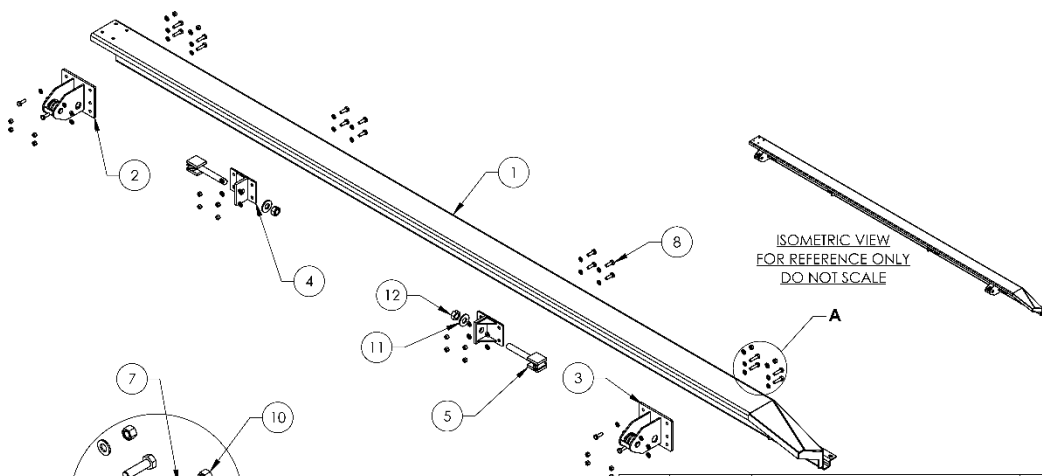

ITEM NO	PART NUMBER	DESCRIPTION	QTY	REV
1	5601277	PL-6K RAMP SIDE RAIL WELDMENT, L.H.	1	A
2	5215680	PL-6K RAMP SHEAVE MOUNT ASSEMBLY, L.H.	1	B
3	5215679	PL-6K RAMP SHEAVE MOUNT ASSEMBLY, R.H.	1	B
4	5600948	PL-6K CABLE ANCHOR WELDMENT	2	B
5	5601253	PL-6K CABLE ANCHOR SOCKET	2	B
6	5545200	WASHER M10 x Ø18 SL	20	--
7	5545341	WASHER M10 x Ø20 FLAT	20	--
8	5530021	HHB, M10 x 1.5 x 30	12	--
9	5530760	HHB M10 x 1.5 x 38	8	--
10	5535013	NUT M10 x 1.5 NL	20	--
11	5545345	WASHER M22 x 50mm FLAT	2	--
12	5535011	NUT M22 x 2.5 NL	2	--

DO NOT SCALE DRAWING	NAME	DATE	BendPak 4621 BAYWOOD DR. SANTA PAULA, CA 95060	
	DRAWN	TG 05/04/2015		
	CHECKED	CA 05/07/2016		
DIMENSIONS ARE IN MILLIMETERS	THIRD ANGLE PROJECTION		TITLE: PL-6K RAMP SIDE RAIL ASSEMBLY, L.H.	
	SIZE	DWG. NO.	REV	
		A	5215677	G
			SCALE: 1:16	SHEET 1 OF 1

DETAIL A
SCALE 1 : 5

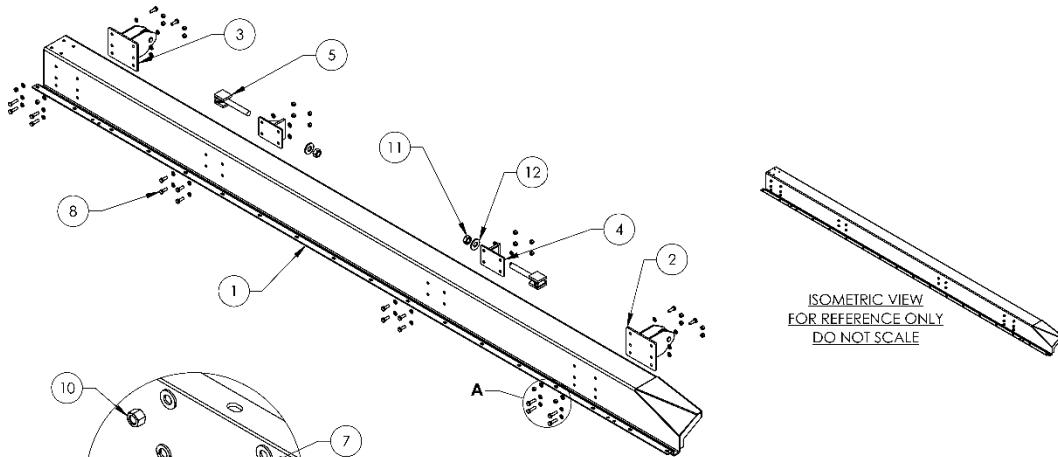

ISOMETRIC VIEW
FOR REFERENCE ONLY
DO NOT SCALE

ITEM NO	PART NUMBER	DESCRIPTION	QTY	REV
1	5601276	PL-6K RAMP SIDE RAIL WELDMENT, R.H.	1	A
2	5215680	PL-6K RAMP SHEAVE MOUNT ASSEMBLY, L.H.	1	B
3	5215679	PL-6K RAMP SHEAVE MOUNT ASSEMBLY, R.H.	1	B
4	5600948	PL-6K CABLE ANCHOR WELDMENT	2	B
5	5601253	PL-6K CABLE ANCHOR SOCKET	2	B
6	5545200	WASHER M10 x Ø18 SL	20	--
7	5545341	WASHER M10 x Ø20 FLAT	20	--
8	5530021	HHB M10 x 1.5 x 30	12	--
9	5530760	HHB M10 x 1.5 x 38	8	--
10	5535013	NUT M10 x 1.5 NL	20	--
11	5535011	NUT M22 x 2.5 NL	2	--
12	5545345	WASHER M22 x 50mm FLAT	2	--

30% NOT SCALE DRAWING

DRAWN: TM 02/24/2015
CHECKED: CA 09/07/2018

THIRD ANGLE PROJECTION

PL-6K RAMP SIDE RAIL ASSEMBLY, R.H.

SCALE: 1:18

SHEET 1 OF 1

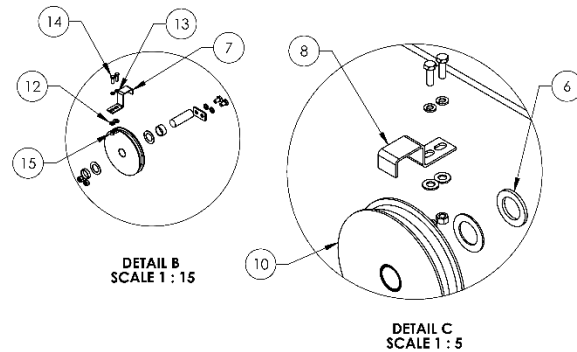
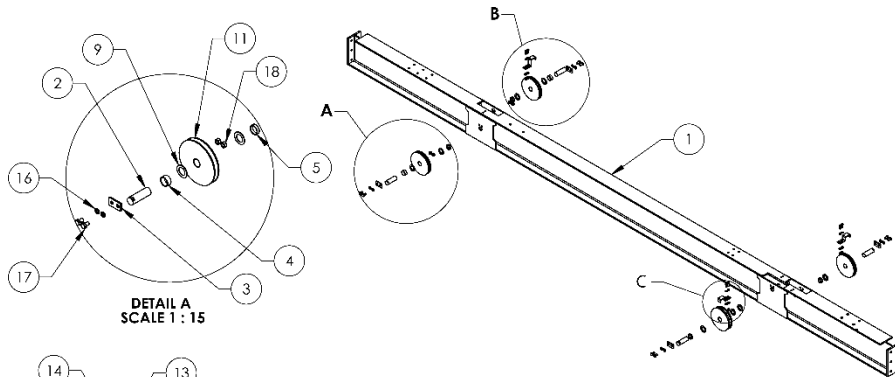

ITEM NO	PART NUMBER	DESCRIPTION	QTY	REV
1	5601607	PL-6K CENTER CROSSBEAM WELDMENT	1	A
2	5746685	PL-6K CROSSBEAM SHEAVE PIN	4	B
3	5736865	PL-6K SHEAVE PIN BOLT PLATE	4	A
4	5735150	PL-6K CROSSBEAM RAMP SHEAVE SPACER	3	A
5	5755151	PL-6K CROSSBEAM RAMP SHEAVE SPACER, SMALL	4	A
6	5746686	PL-6K CROSSBEAM SHEAVE WASHER, LARGE	2	A
7	5701186	PL-6K CROSSBEAM CABLE RETAINER	1	A
8	5701187	PL-6K CROSSBEAM CABLE RETAINER, SMALL	2	A
9	5746687	PL-6K CROSSBEAM SHEAVE WASHER	7	A
10	5215695	PL-6K DOUBLE SHEAVE ASSEMBLY	1	B
11	5215694	PL-6K SINGLE SHEAVE ASSEMBLY	3	A
12	5545341	WASHER M10 x Ø20 FLAT	6	--
13	5545202	WASHER M8 x Ø15 SL	6	--
14	5530010	HHB M8 x 1.25 x 25	6	--
15	5535001	NUT M8 x 1.25 NL	6	--
16	5545201	WASHER, M12 SPRING LOCK	8	--
17	5530184	HHB M12 x 1.75 x 20	8	--
18	5535012	NUT M12 x 1.75 NL	4	--

30% NOT SCALE DRAWING

DRAWN: CA 10/22/2020
CHECKED: OR 08/17/2021

THIRD ANGLE PROJECTION

PL-6K CENTER CROSSBEAM ASSEMBLY

SCALE: 1:30

SHEET 1 OF 1

Automotive Lift Institute (ALI) Store

You probably checked the [ALI's Directory of Certified Lifts](http://www.autolift.org/ali-directory-of-certified-lifts/) (www.autolift.org/ali-directory-of-certified-lifts/) before making your most recent Lift purchase, but did you know the **ALI Store** (www.autolift.org/ali-store/) offers a wide variety of professional, easy-to-use, and reasonably priced training and safety materials that will make your garage a safer place to work?

The ALI Store is your trusted source for workplace safety!

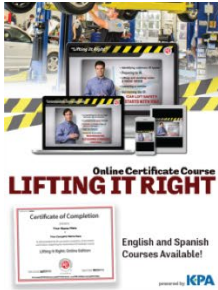

Lifting It Right Online Certificate Course. Make *sure* you and your people are lifting vehicles the right way.



KPA Online Training Subscription. Get all of your people up to speed on automotive industry topics.

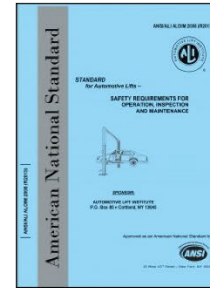

ANSI/ALI ALOIM Standard for Automotive Lifts. Safety Requirements for Operation, Inspection, and Maintenance.

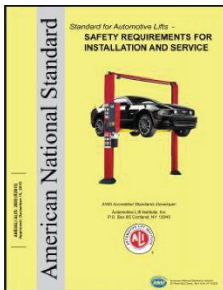

ANSI/ALI ALIS Standard. Safety Requirements for Installation and Service.

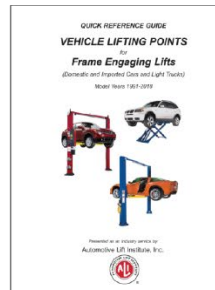

Guide to Hitting Vehicle Lifting Points for Frame-Engaging Lifts. Don't eyeball your lifting points, *know* where they are.



Lift Operator Safety Materials. Five safety documents in a single package.

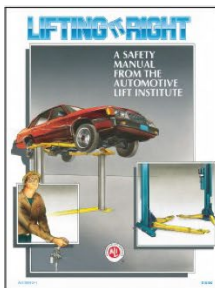

Lifting It Right. A hardcopy version of the *Lifting It Right* safety manual from the Automotive Lift Institute.

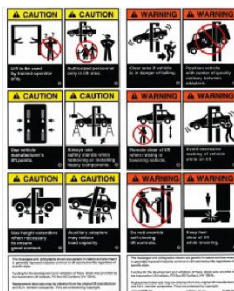

Uniform Warning Labels and Placards for 2-Posts. Labels in Mandarin, French Canadian, and Spanish are also available.



Safety Tips Card. Reminds your people of 13 key safety tips to follow daily.

Visit today and get the training and materials you need to work safely:
www.autolift.org/ali-store/.



1645 Lemonwood Drive
Santa Paula, CA, 93060 USA