

Rolling Bridge Jacks

Installation and Operation Manual

Manual P/N 5900093 — Manual Revision B3 — Released April 2024

Models:

- RJ45LP
- RJ45W
- RJ6W
- RJ7W
- RJ9W

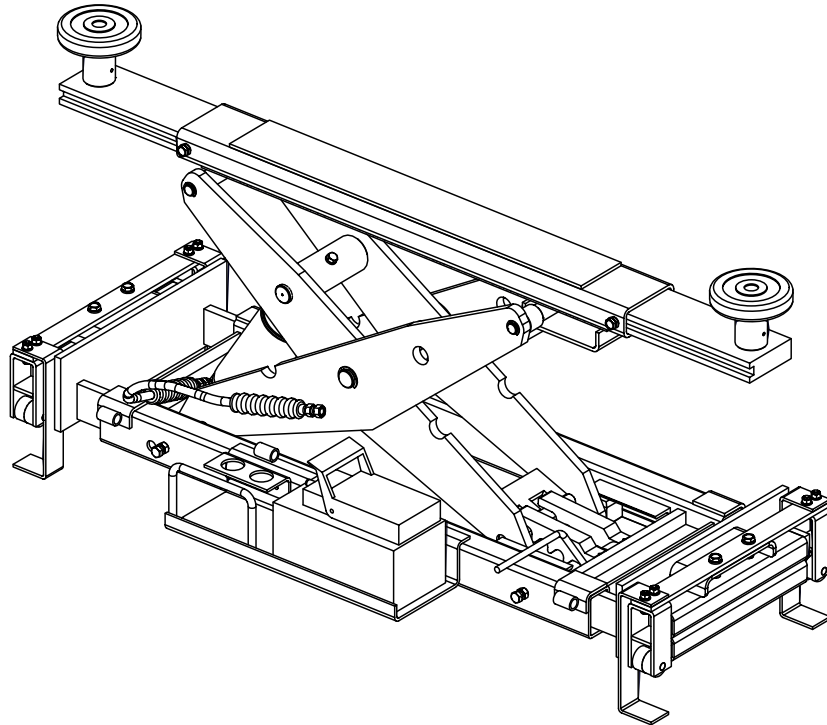

Designed and engineered by BendPak Inc. in Southern California, USA. Made in China.

 **DANGER**

IMPORTANT SAFETY INSTRUCTIONS, SAVE THESE INSTRUCTIONS! Read this manual thoroughly before installing, operating, servicing, or maintaining this Lift. Failure to follow the instructions and safety precautions in this manual can result in serious injury or death. Make sure all other operators also read this manual. Keep the manual near the product for future reference. ***By proceeding with setup and operation, you agree that you fully understand the contents of this manual and assume full responsibility for product use.***

Manual. RJW Series of Rolling Bridge Jacks, *Installation and Operation Manual*, Manual Part Number 5900093, Manual Revision B3, Released April 2024.

Copyright. Copyright © 2024 by BendPak Inc. All rights reserved. You may make copies of this document if you agree that: you will give full attribution to BendPak Inc., you will not make changes to the content, you do not gain any rights to this content, and you will not use the copies for commercial purposes.

Trademarks. BendPak and the BendPak logo are registered trademarks of BendPak Inc. All other company, product, and service names are used for identification only. All trademarks and registered trademarks mentioned in this manual are the property of their respective owners.



Limitations. Every effort has been made to ensure complete and accurate instructions are included in this manual. However, product updates, revisions, and/or changes may have occurred since this manual was published. BendPak reserves the right to change any information in this manual without incurring any obligation for equipment previously or subsequently sold. BendPak is not responsible for typographical errors in this manual. The latest version of this manual is always online at [the BendPak website](#).

Warranty. The BendPak warranty is more than a commitment to you: it is also a commitment to the value of your new product. Contact your nearest BendPak dealer or visit www.bendpak.com/support/warranty for full warranty details. Go to bendpak.com/support/register-your-product/ and fill out the online form to register your product (be sure to click **Submit**).

Safety. Your new product was designed and manufactured with safety in mind. Your safety also depends on proper training and thoughtful operation. Do not set up, operate, maintain, or repair the unit without reading and understanding the safety information in this manual and the labels on the unit. Contact BendPak if you are unclear about any safety aspect of this product; **do not use this product unless you can do so safely!**

Owner Responsibility. In order to ensure operator safety and maintain your product properly, it is the responsibility of the product owner to read and follow these instructions:

- Follow all setup, operation, and maintenance instructions.
- Make sure product setup and use conforms to all applicable local, state, and federal codes, rules, and regulations, such as state and federal OSHA regulations and electrical codes.
- Read and follow all safety instructions. Keep them readily available for operators.
- Make sure all operators are properly trained, know how to safely operate the unit, and are properly supervised.
- Do not operate the product until you are certain all parts are in place and operating correctly.
- Carefully inspect the product on a regular basis and perform all maintenance as specified.
- Service and maintain the unit only with approved replacement parts.
- Keep all instructions permanently with the product and make sure all labels are clean and visible. BendPak makes no promises, guarantees or assurances that our products meet any state, county, federal or international mandated permit, license, code, standard, certification, or any other mandate other than what is listed or shown on BendPak website(s), or any BendPak or Ranger online or published catalog. Not all BendPak lift models meet the standards as prescribed by ANSI/ALI ALCTV-(current edition) or ANSI/UL 201. Consult www.autolift.org for a complete list of lift models that meet ANSI/ALI ALCTV-(current edition) or ANSI/UL 201, or contact BendPak via contact@bendpak.com. Buyer assumes full responsibility for any state, county, federal or international mandated permit, license, code, standard, certification, or any other mandate required related to the installation and/or operation of any BendPak or Ranger product. BENDPAK will not be responsible for any charges, fines, liens, or other levies imposed on the Buyer related to any special or regional structural, seismic or any other building code and/or codes such as the Uniform Building Code (UBC), International Building Code (IBC), or any other state, county, federal or international mandated permit, license, code, standard, certification, or other mandate, law, rule, regulation or directive by any other agency, government, administrations, or corporations whether state, county, federal, or international mandated.
- **Only use the Lift if it can be used safely!**

Unit Information. Enter the Model Number, Serial Number, and the Manufactured On date from the label on your unit. This information is required for part or warranty issues.

Model: _____

Serial: _____

Manufactured On: _____

BP BendPak. Santa Paula, CA USA www.bendpak.com		
MODEL NUMBER		
DESCRIPTION		
LIFT CAPACITY		
DATE CODE	SERIAL NUMBER	
DANGER! Disconnect Power Before Servicing		
UPC		
CE	EAC	
MADE IN CHINA	WARRANTY VOID IF DATA PLATE IS REMOVED	PN 5905150

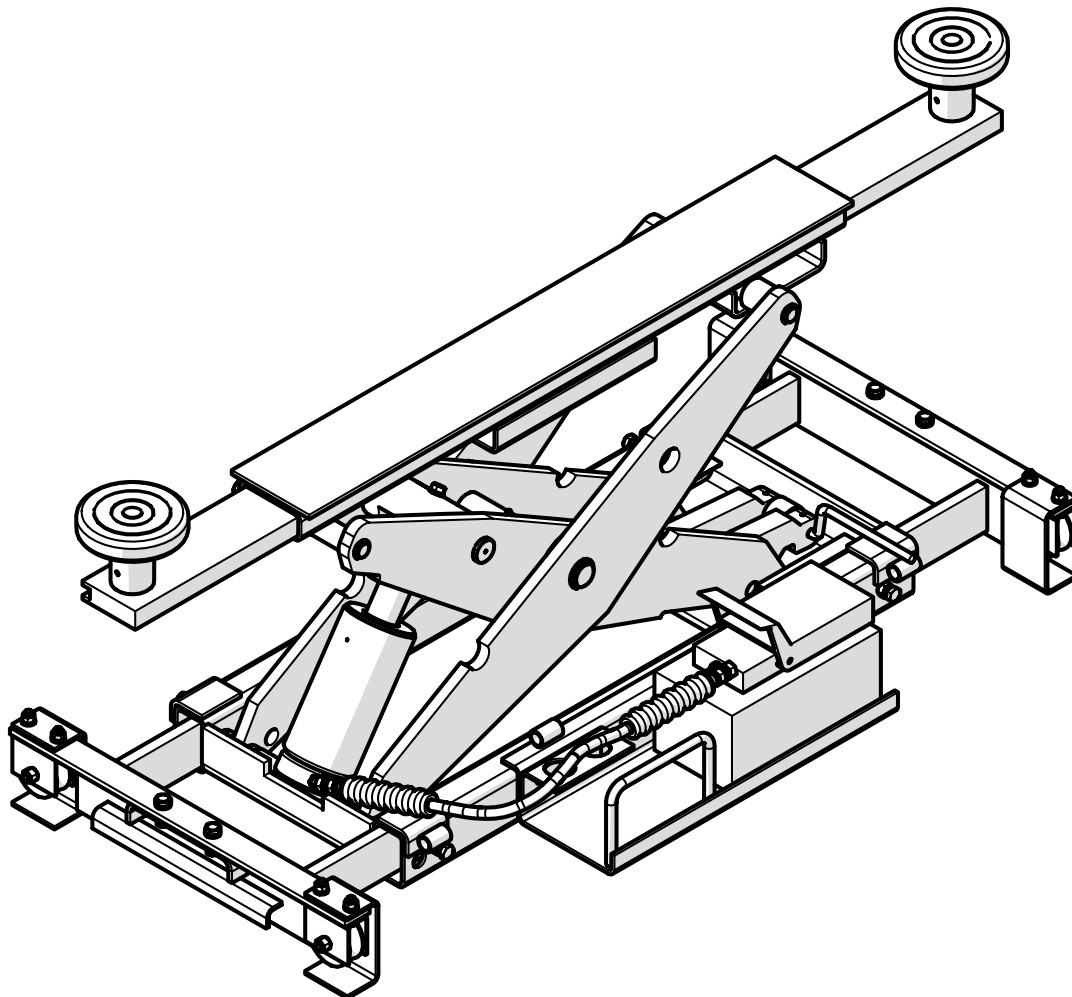

RJ45W Pictured above.

Table of Contents

Introduction	4	Maintenance	31
Shipping Information	5	Troubleshooting	34
Safety Considerations	5	Accessories	34
Components	8	Labels	36
FAQ	10	Parts Sheets	38
Specifications	11	ALI Store	54
Setup	12	Maintenance Log	55
Operation	28		

Introduction

This manual covers the RJW Series of Rolling Bridge Jacks, which are used on four-post Lifts to raise two or four wheels off the Lift's Runway, making brake jobs and suspension work, for example, easier to do. This manual covers the following RJW models:

- **RJ45LP:** Raises *low-profile* Vehicles up to 4,500 lbs. (2,041 kg)
- **RJ45W:** Raises up to 4,500 lbs. (2,041 kg)
- **RJ6W:** Raises up to 6,000 lbs. (2,721 kg)
- **RJ7W:** Raises up to 7,000 lbs. (3,175 kg)
- **RJ9W:** Raises up to 9,000 lbs. (4,082 kg)

All 5 models are ALI Certified accessories for four-post Lifts. ALI is the Automotive Lift Institute (www.autolift.org), an independent organization whose mission is to promote the safe design, construction, installation, inspection, and use of automotive Lifts.

This manual is mandatory reading for all users of these Rolling Bridge Jacks, including anyone who installs, operates, maintains, or repairs them.

⚠ DANGER Be very careful when installing, operating, maintaining, or repairing your unit; failure to do so could result in property damage, product damage, injury, or (in very rare cases) death. Make sure only authorized personnel operate the unit. All repairs must be performed by an authorized technician. Do not make modifications to the unit; this voids the warranty and increases the chances of injury or property damage. Make sure to read and follow the instructions on the labels on the unit.

Keep this manual on or near the equipment so that anyone who uses or services it can read it.

If you are having issues, refer to the **Troubleshooting** section of this manual for assistance. Technical support and service is available from your dealer, on the Web at bendpak.com/support, by email at support@bendpak.com, or by phone at **(800) 253-2363**, select option 7, then 4.

You may also contact BendPak for parts replacement information (please have the model and serial number of your unit available) at **(800) 253-2363**, select option 7, then 5.

Shipping Information

Your unit was carefully checked before shipping. Nevertheless, you should thoroughly inspect the shipment before you sign to acknowledge that you received it.

When you sign the bill of lading, it tells the carrier that the items on the invoice were received in good condition. To protect yourself, do not sign the bill of lading until after you have inspected the shipment. If any of the items listed on the bill of lading are missing or are damaged, do not accept the shipment until the carrier makes a notation on the bill of lading that lists the missing and/or damaged goods.

If you discover missing or damaged goods after you receive the shipment and have signed the bill of lading, notify the carrier at once and request the carrier to make an inspection. If the carrier will not make an inspection, prepare a signed statement to the effect that you have notified the carrier (on a specific date) and that the carrier has failed to comply with your request.

It is difficult to collect for loss or damage after you have given the carrier a signed bill of lading. If this happens to you, file a claim with the carrier promptly. Support your claim with copies of the bill of lading, freight bill, invoice, and photographs, if available. Our willingness to assist in helping you process your claim does not make us responsible for collection of claims or replacement of lost or damaged materials.

Safety Considerations

Read this manual carefully before using your new product. Do not set up or operate the product until you are familiar with all operating instructions and warnings. Do not allow anyone else to operate the product until they are also familiar with all operating instructions and warnings.

 **WARNING California Proposition 65.** This product can expose you to chemicals including styrene and vinyl chloride which are on the list of over 900 chemicals identified by the State of California to cause cancer, birth defects or reproductive harm. Always use this product in accordance with BendPak's instructions. For more information, visit www.p65warnings.ca.gov.

Rolling Bridge Jack Safety Information

 **DANGER Crushing hazard and pinch points.** Do not place any part of your body between the top deck and any moving part of the Lift unless visual confirmation is made that the safety lock is fully engaged, and that the Lift's downward motion is blocked by a Jack Stand, Forklift or other Load-Holding device that will prevent the Lift's downward movement while working under it.

 **WARNING** When the Rolling Bridge Jack is on a raised Lift, **do not go under it!** If you notice a Roller out of position, get everyone out from under the Lift, carefully lower the Lift, reposition the Rollers back onto the Utility Rail, and then make sure the Safety Brackets and Adjustment Bolts are correctly installed and adjusted.

 **WARNING Rolling Bridge Jack components are heavy and awkward to work with.** Installation should be accomplished by competent personnel ensuring all heavy components are properly rigged and balanced for lifting. Installation personnel should have knowledge, training, and experience in lifting, rigging, and securing heavy objects. Utilize shop cranes or similar.

IMPORTANT SAFETY INSTRUCTIONS!





Save these instructions!

1. Read all instructions.
2. Care must be taken as burns can occur from touching hot parts.
3. Do not operate equipment with a damaged cord, hoses, or if the equipment has been dropped or damaged – until it has been examined by a qualified service person.
4. Do not let a cord or hoses hang over the edge of a table, bench, or counter or come in contact with hot manifolds or moving fan blades.
5. To reduce the risk of fire, do not operate in the vicinity of open containers of flammable liquids (gasoline).
6. Adequate ventilation should be provided when working on operating internal combustion engines.
7. Keep hair, loose clothing, fingers, and all parts of body away from moving parts.
8. To reduce the risk of electric shock, do not use on wet surfaces or expose to rain.
9. Use only as described in this manual. Use only BendPak recommended attachments.
10. ALWAYS WEAR SAFETY GLASSES. Everyday eyeglasses only have impact resistant lenses, they are not safety glasses.
11. To reduce the risk of injury, close supervision is necessary when product is used around children.
12. To reduce the risk of injury, **never** lift more than the rated capacity. Refer to loading instructions.
13. Only operate your Lift between temperatures of +41°F to +104°F (+5°C to +40°C).
14. The Lift should **only** be operated by authorized personnel. Keep children and untrained personnel away from the Lift.
15. Do not make any modifications to the Lift; this voids the warranty and increases the chances of injury or property damage.
16. Do not use the Lift while tired or under the influence of drugs, alcohol, or medication.
17. Consider the work environment. Keep the work area clean. Cluttered work areas invite injuries. Keep areas well lit.
18. **Always** make sure the Lift is secured on Safety Locks before attempting to work on or near a Vehicle.
19. Make a thorough inspection of the product at least once a year. Replace any damaged or severely worn parts, decals, or warning labels. Replace worn or damaged parts with BendPak or BendPak approved parts and assemblies only.
20. BendPak recommends referring to the ANSI/ALI ALIS Standard *Safety Requirements for Installation and Service* for more information about safely installing, using, and servicing your Lift.
21. RJ Series Jacks are Rolling Bridge Jacks. **Use them only for their intended purpose.**

-
22. You **must** wear OSHA-approved (publication 3151) personal protective equipment at all times when installing, using, maintaining, or repairing the Lift. Leather gloves, steel-toed work boots, eye protection, back belts, and hearing protection are **mandatory**.
- Keep loads balanced on the Lift Arms. Clear the area immediately if a Vehicle is in danger of falling off the Lift. Do not make any modifications to the Lift.
23. Modifications void the warranty and increases the chances of injury or property damage. **Do not modify any safety-related features in any way.**
24. Make sure all operators read and understand this Installation and Operation Manual. **Keep the manual near the Lift at all times.**
25. While handling a Hydraulic Cylinder or a Hydraulic Hose, **always** wear gloves. In rare cases, a needle-like stream of hydraulic fluid (even at low pressure) can penetrate fingers, hands, or arms; such a puncture can feel like a bite, electric shock, or a prick. While it may seem like a minor issue, any amount of Hydraulic Fluid injected into the human body is a serious issue. Anyone suffering such a puncture wound should be **immediately** taken to a hospital emergency room to determine the extent of the injury. Explain the circumstances of the injury to the attending physician, including what kind of Hydraulic Fluid was involved. Do not assume a puncture wound that could have been caused by Hydraulic Fluid is a minor issue; it could be life threatening.
26. Make an inspection of the Jack **before** using it. Check for damaged, worn, or missing parts. Do not use it if you find any of these issues. Instead, take it out of service, then contact an authorized repair facility, your dealer, or BendPak at **(877) 432-6627** or support@BendPak.com.
27. To reduce the risk of property damage, personal injury, or loss of life, **NEVER** park any vehicle on the Lift's runways without placing suitable wheel chocks behind each rear tire so that the vehicle cannot roll backward from Lift. Vehicles parked on Lift **MUST** also be placed in Park or First Gear (Manual Transmission) with the Parking Brake fully applied.
28. **Make sure the Rolling Jack is engaged on its Safety Locks before starting work.**
29. Verify the Vehicle being raised by a Rolling Jack does **not** exceed its maximum lifting capacity.

Symbols

Following are the symbols used in this manual:

-  **DANGER** Calls attention to an immediate hazard that **will** result in death or severe injury.
-  **WARNING** Calls attention to a hazard or unsafe practice that **could** result in death or severe personal injury.
-  **CAUTION** Calls attention to a hazard or unsafe practice that could result in minor personal injury, product, or property damage.
- NOTICE** Calls attention to a situation that could result in product or property damage.
- Tip**  Calls attention to information that can help you use your product better.

Liability Information

BendPak assumes **no** liability for damages resulting from:

- Use of the product for purposes other than those described in this manual.
- Modifications to the equipment without prior, written permission from BendPak Inc.
- Injury or death caused by modifying, disabling, overriding, or removing safety features.
- Damage to the equipment from external influences.
- Incorrect operation of the equipment.

Components

Rolling Jack components include:

- **Scissor Structure.** Rolling Jacks are scissor lifts that are powered by hydraulic pressure from the Air-Driven Hydraulic Pump.
- **Air-Driven Hydraulic Pump.** Provides hydraulic power to the Rolling Jack. The Air-Driven Hydraulic Pump must be attached to an air supply: 20 cubic feet per minute (0.57 cubic meters per minute) at 100 psi minimum (7 bar).
- **Foot Pedal.** Raises and lowers the Rolling Jack. Despite its name, you can use the Foot Pedal with your hands or your feet. Located on the top of the Hydraulic Pump.
- **Hydraulic Hose.** Connects the Air-Driven Hydraulic Pump to the Hydraulic Cylinder; delivered connected.
- **Hydraulic Cylinder.** Moves the Scissor Structure up and down.
- **Safety Locks.** Hold the Rolling Jack in place once engaged. Always leave your Rolling Jack either fully lowered or engaged on its Safety Locks; **never leave a Rolling Jack in an unlocked position with a Vehicle on it.**

 **WARNING** Before starting work on a Vehicle, make sure the Rolling Jack is engaged on its Safety Locks and the Lift Pads are in contact with frame or chassis lift points on the underside of the Vehicle.

- **Safety Handle.** Moves the Rolling Jack off its Safety Locks so it can be lowered.
- **Adjustable Arms.** Slide in and out so you can precisely position the Lift Pads on the frame or chassis lift points of the Vehicles you are lifting.
- **Lift Pads.** Position them under the frame or chassis lift points on the underside of the Vehicle. Lift Pads fit into the holes on the end of the Adjustable Arms.



Tip

If you have an RJ45W and want more control over where the Rolling Jack contacts the frame or chassis lift points on the underside of Vehicles, the RJ45W Adapter Kit includes two sliding rubber contact pads and two sliding receivers.

- **Lift Pad Extenders.** Allow you to raise the height of the Lift Pads to better contact the frame or chassis lift points on Vehicles. Two Medium and two Tall Extenders are included with the Rolling Jack.
- **Extender Holder.** Hold the Lift Pad Extenders when you are not using them.
- **Moving Handle.** Used to move the Rolling Jack. Not the same thing as the Safety Handle.
- **Extendable Bases.** Move in and out to accommodate the distance between the Lift's Runways.
- **Rollers.** Located on the ends of the Extendable Bases, the Lip Rollers or Channels Rollers sit on the Utility Rail Lip or in the Utility Rail Channel and let you move the Rolling Jack. Models RJ45W, RJ6W, and RJ7W have Lip Rollers. Model RJ9W has Channel Rollers.
- **Safety Brackets.** A safety feature, they hold the Rolling Jack in place on the Utility Rail. Installed after the Jack is put into place. **Installation is required.**
- **Adjustment Bolts.** They secure the Extendable Bases in place. They arrive installed, but not securely tightened. **Tightening is required.**

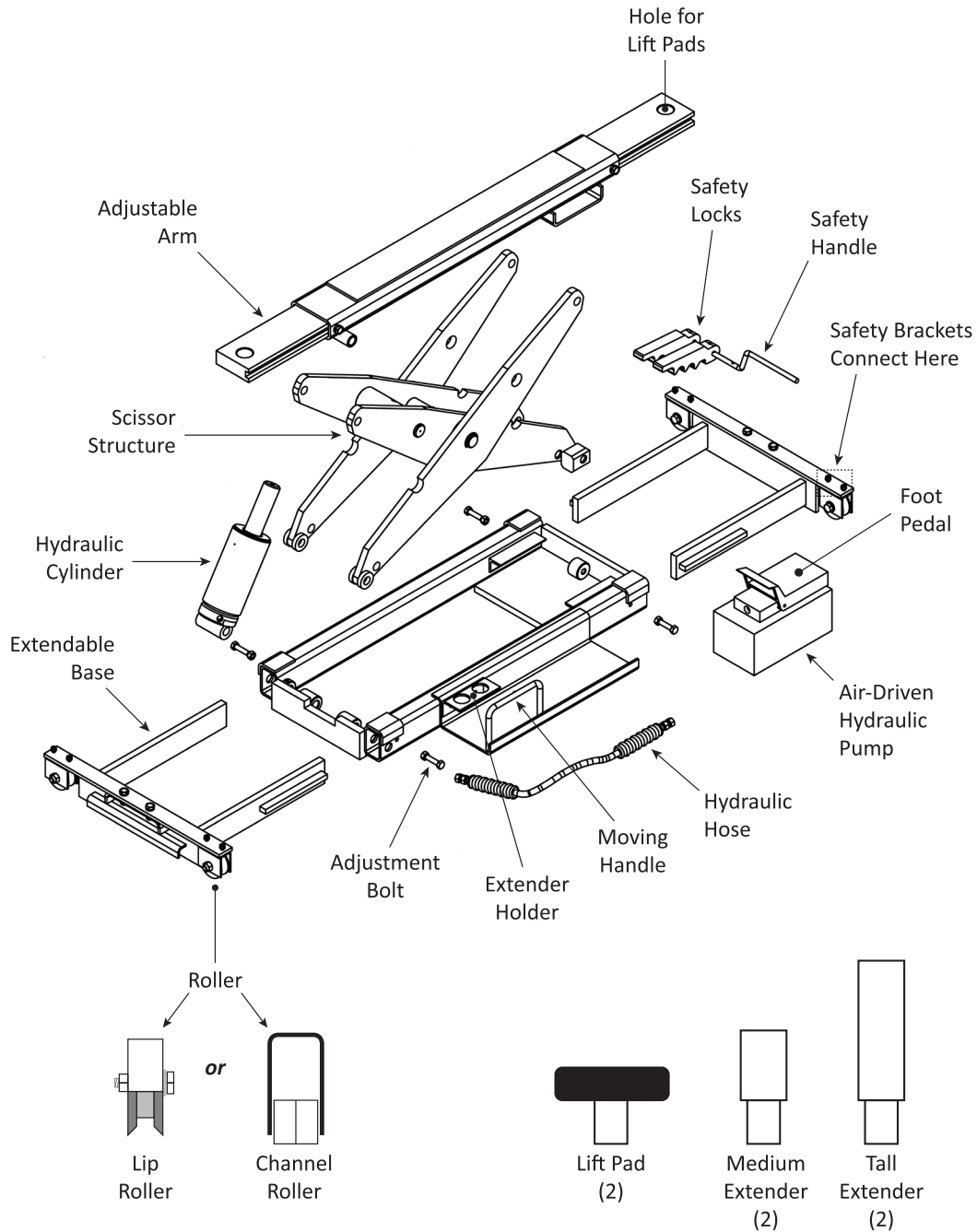

Model RJ7W shown. Some models vary slightly. Not to scale. Some components larger for clarity.

Frequently Asked Questions

Question: What kinds of Vehicles can I raise on my Rolling Jack?

Answer: A wide range of Vehicles. There are multiple Rolling Jack models, each supporting different weight capacities, so a wide range of Vehicles can be raised.

Q: If a Vehicle is already raised on a four-post Lift, why do I need a Rolling Jack?

A: A Rolling Jack gives you the option of raising two or four wheels of the Vehicle off the Runway, which makes certain automotive services (brake jobs, suspension work, tire changes, and so on) easier. Each Rolling Jack can raise two wheels of the Vehicle via an axle housing, suitable suspension members, frame lifting points, etc.). Therefore, to raise **four wheels** off the Runway, you need **two** Rolling Jacks. Note: **Do Not use the Rolling Jack to lift from any steering linkage or open axle shafts. Component damage may occur.**

Q: How does a Rolling Jack work?

A: Each Rolling Jack is positioned between the Runways of a four-post Lift, such as an HD-9. They are used to raise the front or the rear of the Vehicle up off the Runway, typically via their axle housings or suspension members. To access drive train or suspension members, lift the vehicle from the frame lifting points. With the Wheels off the Runways, chassis repairs are more accessible.

Q: What Rolling Jack goes with what BendPak Lift?

A: Rolling Jacks are associated with specific BendPak Lifts, based on weight capacities. So, if you have a BendPak HD-**14** Lift, for example, you will need two RJ**7**W Rolling Jacks. Each Jack can only raise up to half of the weight for which the Lift is rated.

Q: Can I use a Rolling Jack on an Alignment Lift?

A: Yes. They work the same on an Alignment Lift.

Q: Are Rolling Jacks heavy?

A: Yes. You need a Shop Crane or Forklift to put them into position and you must not stand or walk under them. Your Rolling Jack was designed to stay in place, but you should always use extreme care when walking around under Lifts, raised Vehicles, and Rolling Jacks. **BendPak strongly recommends walking around rather than under any raised Vehicle.**

Q: Why are the bases of a Rolling Jack extendable?

A: To accommodate different widths between Runways on some four-post Lifts.

Q: How is a Rolling Jack powered?

A: Via air pressure (that you supply) that connects to the Air-Driven Hydraulic Pump. The optional Air Line Kit (5174009) makes this easy; visit [the website page](#) for more information.

Q: How many Safety Lock positions does my Rolling Jack have?

A: Three. This gives you three heights to which you can raise and hold the Vehicle, whichever is best for the work you want to do.

Q: How long can I leave a Vehicle raised on my Rolling Jack?

A: For quite some time, as long as you leave the Rolling Jack engaged on its Safety Locks. Once the Safety Locks are engaged, gravity holds the Vehicle up, so a loss of air or hydraulic pressure has no impact; your Vehicle is going to stay where you left it. **Always leave your Rolling Jack either fully lowered or engaged on its Safety Locks.**

Specifications

Model	RJ45LP	RJ45W
Lifting capacity	4,500 lbs. (2,041kg)	4,500 lbs. (2,041 kg)
Minimum Drive-Over Height (Pad only)	4" (100 mm)	4.25" (105.4 mm)
Maximum Lifting Height (Pad only)	14.85" (377.2 mm)	15" (382.7 mm)
Minimum arm reach	42" (1,068 mm)	42" (1,068 mm)
Maximum arm reach	61" (1,549 mm)	57" (1,449 mm)
Maximum operating hydraulic pressure	2,490 psi	2,490 psi
Minimum operating air pressure required	100 psi	100 psi
Shipping weight	306 lbs. (139 kg)	380 lbs. (172 kg)

Model	RJ6W	RJ7W	RJ9W
Lifting capacity	6,000 lbs. (2,721 kg)	7,000 lbs. (3,175 kg)	9,000 lbs. (4,082 kg)
Min. Drive-Over Height (Pad only)	4" (100 mm)	3.75" (96 mm)	5" (123.8 mm)
Max. Lifting Height (Pad only)	14.75" (375 mm)	14.75" (375 mm)	15.75" (399 mm)
Minimum arm reach	42" (1,062 mm)	42" (1,062 mm)	42" (1,062 mm)
Maximum arm reach	56" (1,426 mm)	56" (1,426 mm)	56" (1,426 mm)
Maximum operating hydraulic pressure	3,370 psi	4,550 psi	5,020 psi
Min. operating air press.	100 psi	100 psi	100 psi
Shipping weight	426 lbs. (193 kg)	431 lbs. (195 kg)	445 lbs. (206 kg)

Specifications are subject to change without notice.

About Vehicle Wheelbases

A four-post *Lift's* rated lifting capacity is originally determined with data that is contingent on a specific wheelbase length. When a vehicle placed on the lift features a wheelbase that is less than the original specified wheelbase length, the total lifting capacity of the lift will lessen. This is because shorter wheelbase Vehicles concentrate their weight to the middle of the Runways, where there is less supporting structure and more leverage. Consequently, the rated lifting capacity measured in pounds, will decline in relationship to a respective vehicle's shorter wheelbase dimension.

For example, if you want to raise a Vehicle with a wheelbase of only 100" on an HD-14T Lift (14,000 lbs.; rated and designed for a 135" wheelbase), the rated capacity of the Lift in this example is reduced by 50% to 7,000 lbs. (3,175 kg).

This reduced capacity, based on Vehicle wheelbase does not impact the separately rated capacity of the Rolling Jacks used on those Lifts.

Rated capacity information is included in the Specifications section in the manual of all four-post Lifts. Refer to the manual for a specific Lift for additional information.

Setup

This section describes how to set up your Rolling Jack.

Safety Rules

When installing a Rolling Jack, your safety depends on proper training and thoughtful operation.

⚠ WARNING Do not install this equipment unless you have automotive lift installation training. Always use proper lifting tools, such as a Forklift or Shop Crane, to lift heavy components. Do not install this equipment without reading and understanding this manual and the safety labels on the unit.

Only fully trained personnel should be involved in installing this equipment. Pay attention at all times. Use appropriate tools and lifting equipment. Stay clear of moving parts.

⚠ WARNING You must wear appropriate protective equipment during setup: leather gloves, steel-toed work boots, eye protection, back belts, and hearing protection.

Tools

You may need some or all of the following tools:

- Hex key wrench set
- Medium adjustable wrench
- Forklift, Shop Crane, or other heavy lifting device
- Medium flat screwdriver
- Tape measure, 25' or longer
- Air fitting, to connect the Air-Driven Hydraulic Pump to air pressure

Preparing the Rolling Jack

After your Rolling Jack arrives, there are some tasks to complete to prepare it for normal operation:

- **Remove it from its container.** The Rolling Jack arrives in a wooden container that protects it during transport.

To remove the Jack from its wooden container:

1. Where the Top meets the Sides, push the metal tabs all the way down, on all four sides.
2. You may have to apply some force to move all of the metal tabs free.
3. Pry the Top off.
4. Remove the Accessory Box with components.
5. With capable assistants if needed, lift, and remove the two Roller Assemblies and Rolling Jack.

Verify all items are present. The Shipping Container should include:

- The Accessory Box, which holds the Manual, two black round Lift Pads, two Medium Extenders, and two Tall Extenders.
- Four Safety Brackets.
- Two Roller Assemblies.
- The Rolling Jack, including the Air-Driven Hydraulic Pump.

If any of these items are missing, contact your dealer, go to bendpak.com/support, email support@bendpak.com, or call **(800) 253-2363**.

Install the Roller Assemblies. You must install a Roller Assembly on each end of the Rolling Jack.

To install a Roller Assembly:

1. Raise the Rolling Jack off the ground by at least three inches.
2. Remove the two Bolts, Washers, and Nuts in the middle of each Roller Assembly.
3. Orient a Roller Assembly over the Extendable Base on one end of the Rolling Jack.
The Nyloc Nut holding the Roller in place must face the outside of the Rolling Jack.

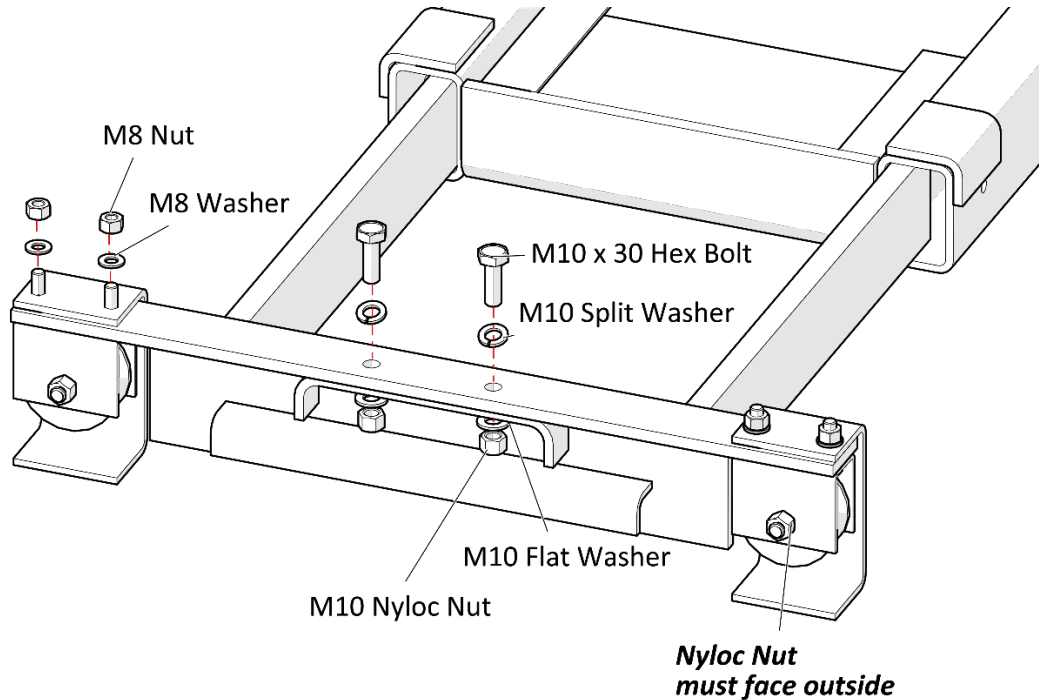

Not to scale. Not all components shown. Top view.

4. Replace the two Bolts in the middle of each Roller Assembly and **securely** tighten them.

Preparing the Lift

Rolling Jacks go into the open space between the two Runways of a four-post Lift.

Keep the following in mind:

- **The Lift must be installed properly and operating normally.** Only use a Rolling Jack with a Lift that has been installed according to the manufacturer's instructions and is operating normally per those instructions.

⚠ WARNING Do not set up or use a Rolling Jack if the Lift is not the model the Rolling Jack was designed for, or the Lift was improperly installed. Instead, contact the manufacturer of the Lift or BendPak Customer Service at **(800) 253-2363** for instructions.

- **The Lift must be lowered.** Before putting your Rolling Jack into position between the Runways, fully lower the Lift or set it on its lowest Safety Lock position.

💡 Tip If you are going to be using a Crane to position your Rolling Jack, you may need to lock the Lift on the lowest Safety Lock position to make room for the legs of the Crane.

- **You can only use the Rolling Jack in certain locations on the Lift.** This is because the strength of the Lift is less in the middle, so raising a Vehicle in the middle could permanently

damage the Lift's Runways. And most vehicles do not have adequate lift points in the middle of the chassis.

⚠ CAUTION Using Rolling Jacks in the middle of the Lift could permanently damage the Lift's Runways. **Damage caused by this unsupported use of Rolling Jacks is not covered by the warranty.** Most vehicles do not have adequate lift points in the middle of the chassis. See figure below.

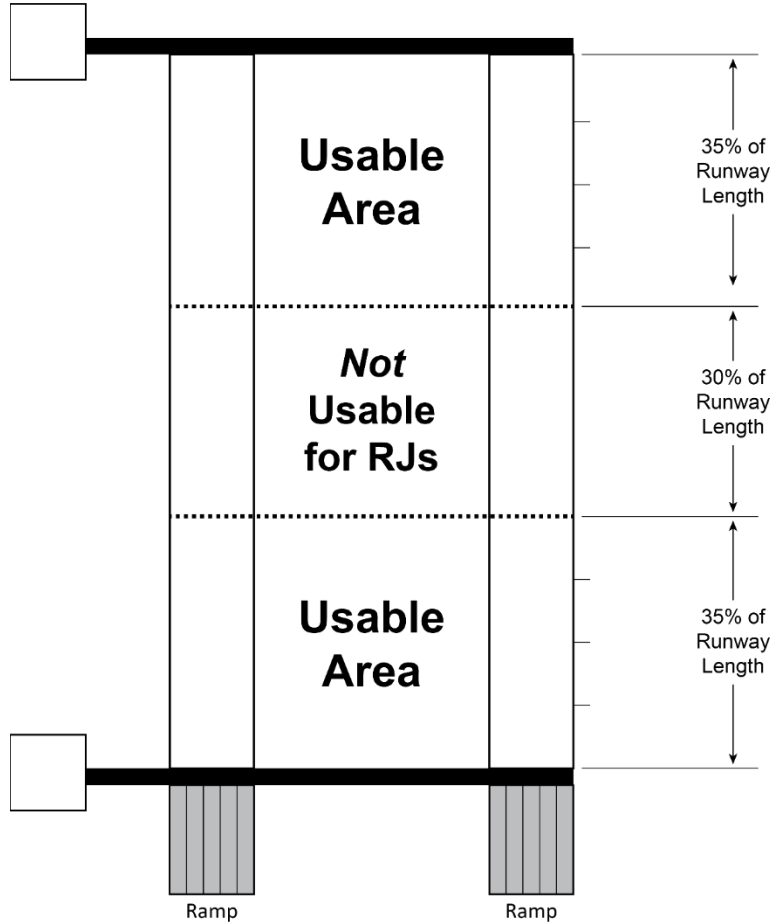

Drawing not to scale. Not all components shown. Top view.

So, what does this information mean:

- If you are using **one** Rolling Jack on your Lift, do not use it in the unusable area.
- If you are using **two** Rolling Jacks on your Lift, center the Vehicle between the Front and the Back of the Runways, over the area that is not usable for Rolling Jacks. This gives you the most room on the two ends (the usable areas) for your Rolling Jacks.
- If you are using **two** Rolling Jacks, they must never be closer to each other than 30% of the length of the Runway of the Lift they are on, nor can either one be used in the unusable area.

Check the Specifications for your Lift for the length of the Runways and additional information.

- **The Lift Runways must be parallel.** Make sure the Lift Runways were installed parallel to each other. The distance between the Runways **must be equal** along the entire length of the Lift.

⚠ WARNING If the Lift Runways are **not** parallel, moving the Rolling Jack could force it off the Utility Rail, increasing the chances it could fall and be damaged or cause injury. If Lift Runways are not parallel, take the Lift out of service and have it adjusted so that the Lift Runways are parallel. Then can you use your Rolling Jack on the Lift.

In the following drawing, the distance between the Runways at Points A, B, and C must be the same. If they differ, moving the Rolling Jack will be more difficult.

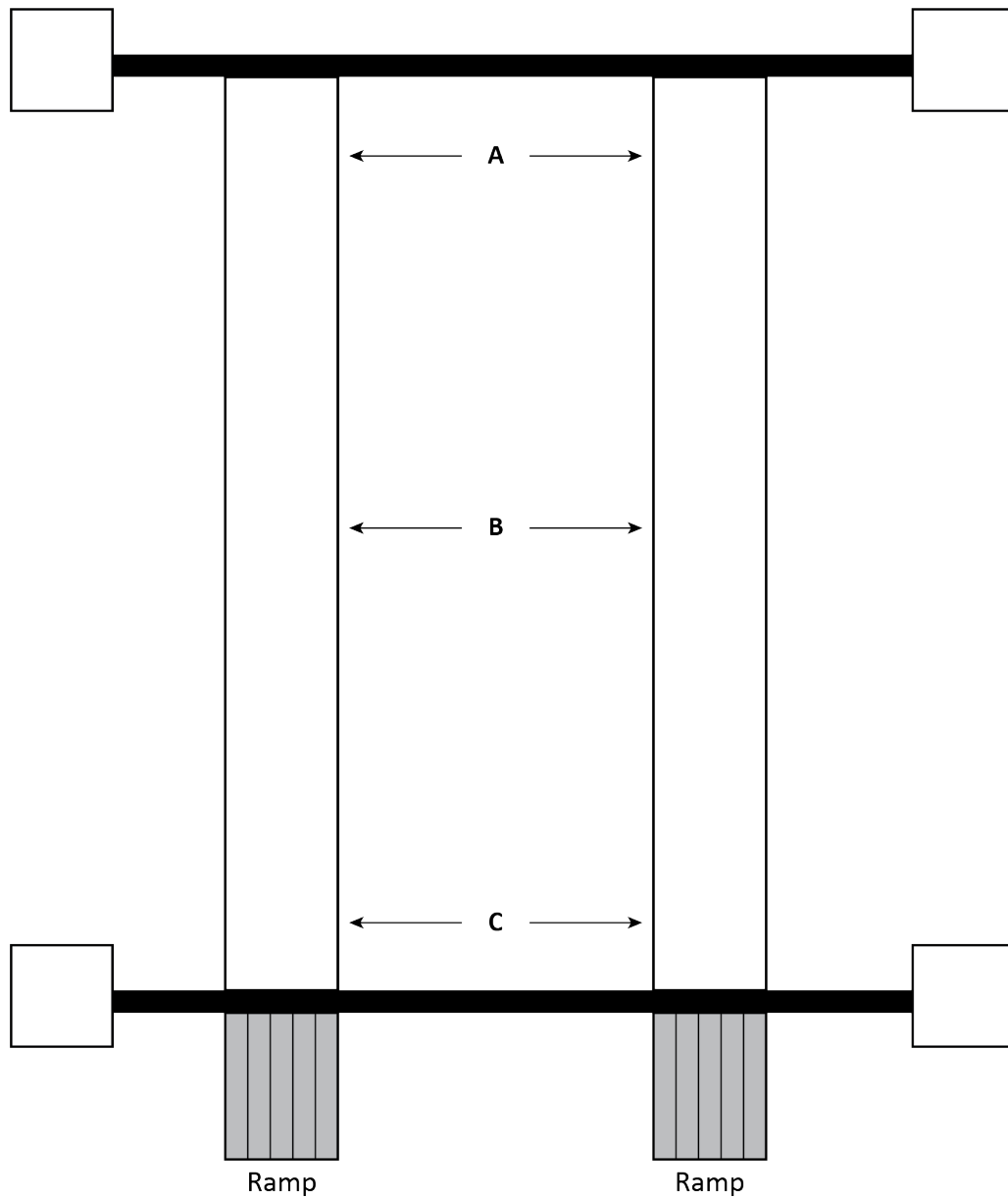

Drawing not to scale. Not all components shown. Top view.

- **Orienting the Pump on the Lift.** You need to orient each Rolling Jack such that the Air-Driven Hydraulic Pump is facing the closest Crosstube, the outside of the Lift. This makes it easier to route the integrated air lines and access the Air-Driven Hydraulic Pump.
- **IMPORTANT!** The Hydraulic Pump will run with either dry or lubricated compressed air. Lubricated air is preferred to extend the life of the internal pump components.

When using two Rolling Jacks on a Lift, orient both pumps towards the outside of the Lift.

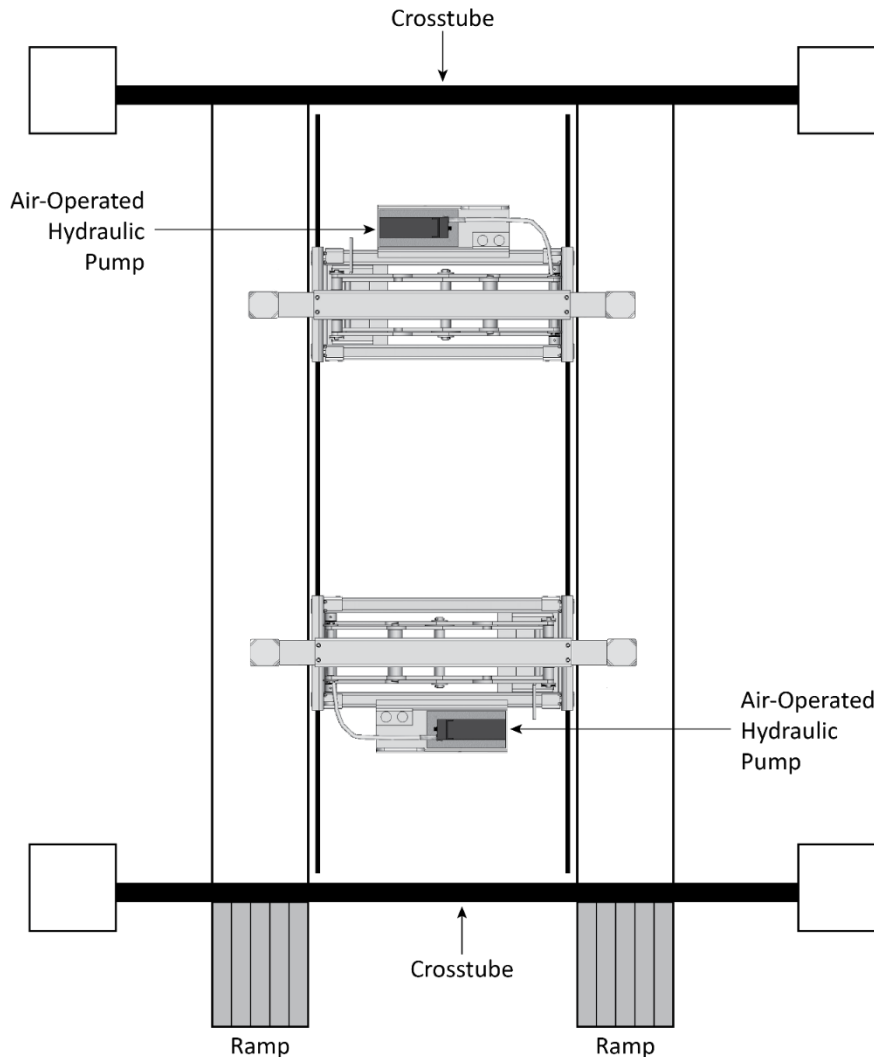

Drawing not to scale. Not all components shown. Top view.

Note: BendPak HDSO model Lifts do **not** have a Front Crosstube; they are open in the front. If you have two Rolling Jacks on an HDSO Lift, orient the Air-Driven Hydraulic Pump on the Rolling Jack at the front of the Lift towards the open front of the Lift.

Moving the Rolling Jack into Position

Rolling Jacks need to be moved into position on the four-post Lift using a Forklift, Shop Crane, or other device appropriate for lifting heavy loads.

Once in position, you need to tighten the Adjustment Bolts and install the Safety Brackets.

⚠ WARNING Pay close attention when moving the Rolling Jack into position; the weight is not evenly distributed. Make sure the Rolling Jack is held **securely** by a Forklift, Shop Crane, or other device appropriate for lifting heavy objects. Rolling Jacks weigh approximately 300 lbs. to 450 lbs. depending on model.

To raise a Rolling Jack into position on a four-post Lift:

1. Make sure the four-post Lift is either fully lowered or engaged on Safety Locks.
2. Make sure the Runways are the desired width apart and adjust Rolling Jack width to correspond.
3. Using a Shop Crane, Forklift, or other lifting device, raise the Rolling Jack and orient it appropriately between the Lift's two Runways. **Do not lower it onto the Utility Rail yet.**

Remember to orient the Air-Driven Hydraulic Pump side appropriately: the Pump side of the Jack should face towards the Crosstubes of the Lift (*not towards the inside*).

4. Lower the Rolling Jack to just above the Utility Rails. **Do not lower the Rolling Jack all the way down onto the Utility Rails yet.**
5. Adjust the Extendable Bases of the Rolling Jack to the correct width.

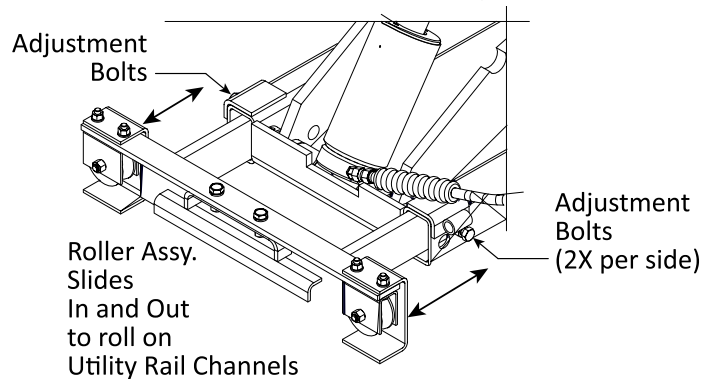

The correct width is where the Lip Roller is directly centered over the Utility Rail Lip or the Channel Roller is directly over the Utility Rail Channel.

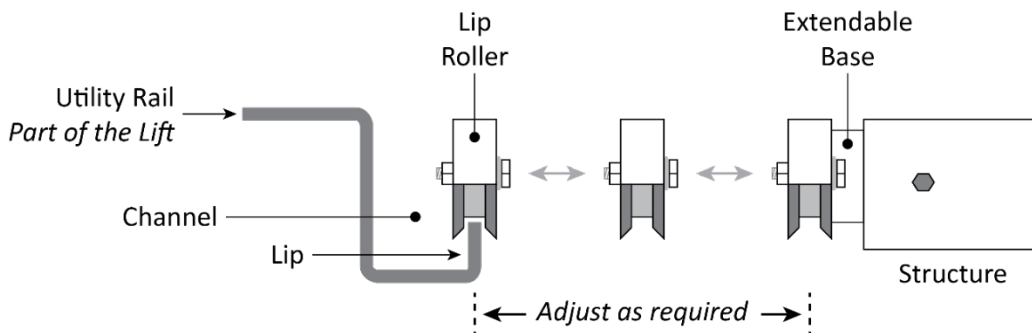

Not to scale. Not all components shown. Side view. Shows Lip Roller over Utility Rail Lip.

6. Confirm that all four Rollers are over the correct locations on the Utility Rails.

7. Lower the Rolling Jack onto the Utility Rail Lip or into the Utility Rail Channel, depending on model. Tightly secure all four Adjustment Bolts on Rolling Jack.

Before driving a vehicle over the Rolling Jack read the following!

⚠ WARNING

Visually check undercarriage clearance as a vehicle is driving over the Rolling Jack. Aftermarket engine equipment, body components, special performance suspensions, exhaust, etc. may produce less-than-stock clearance. Note that even original vehicles may have components or previous repairs that may interfere with the Rolling Jack's clearance.

The following drawing shows a Lip Roller on the Utility Rail Lip. *Models RJ45W, RJ6W, and RJ7W use Lip Rollers.*

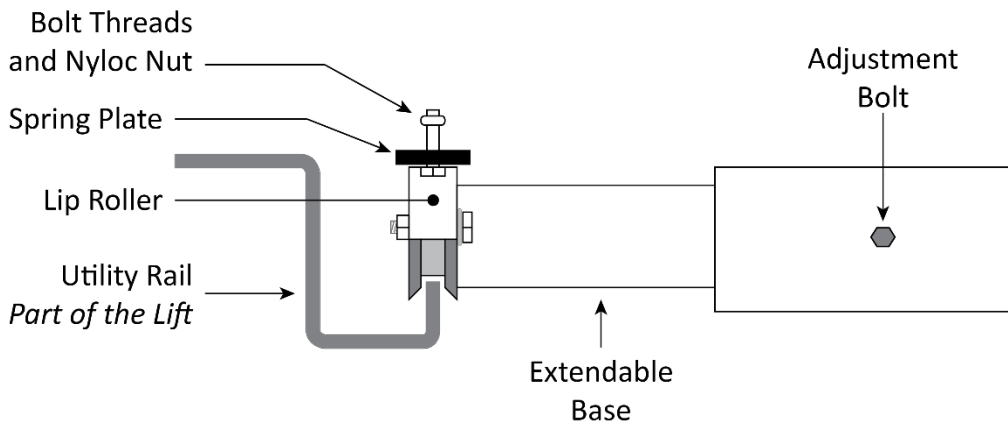

Not to scale. Not all components shown. Safety Brackets not yet installed. Side view.

The following drawing shows a Channel Roller in the Utility Rail Channel. *Model RJ9W uses Channel Rollers.*

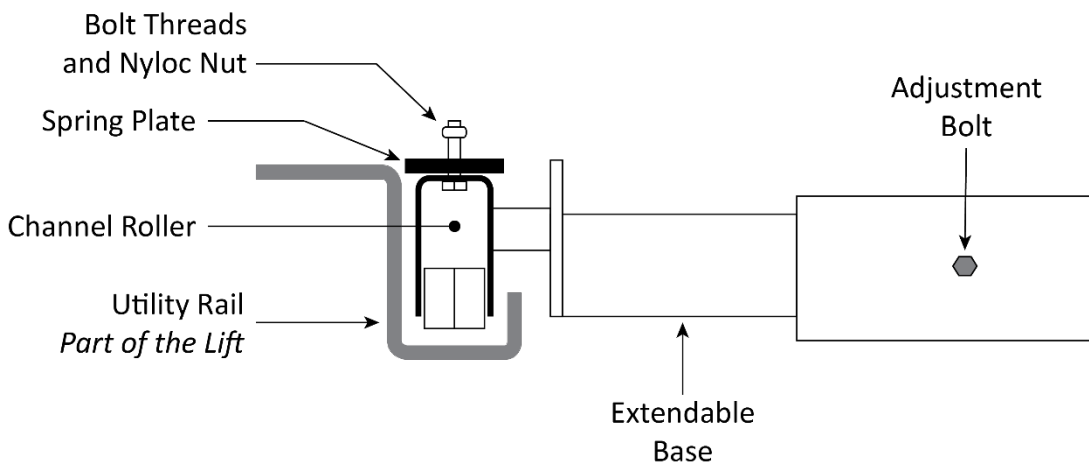

Not to scale. Not all components shown. Safety Brackets not yet installed. Side view.

8. Make sure the Utility Rail Channel is clear of debris, then carefully move the Rolling Jack a short distance in both directions to verify operation. Check to make sure all Rollers are either on the Utility Rail Lip or in the Utility Rail Channel.

- When the Rolling Jack is correctly situated on the Utility Rail Lip or in the Utility Rail Channel and operation has been checked, securely tighten all four Adjustment Bolts. This holds the Extendable Bases in place.

⚠ WARNING You are **required** to securely tighten all four Adjustment Bolts. This ensures the Jack stays in place on the Utility Rails. If the Adjustment Bolts are not tightened, there is a possibility the Rolling Jack could fall off the Lift, causing damage or injury.

- Find the Safety Brackets that came with the Rolling Jack.
- Remove the Nyloc Nuts at the top of the Bolt Threads coming up from the top of the Roller.
- Put a Safety Bracket into place on the Bolt Threads—the Safety Bracket goes on the Rolling Jack side, not the Utility Rail side (see drawing below).

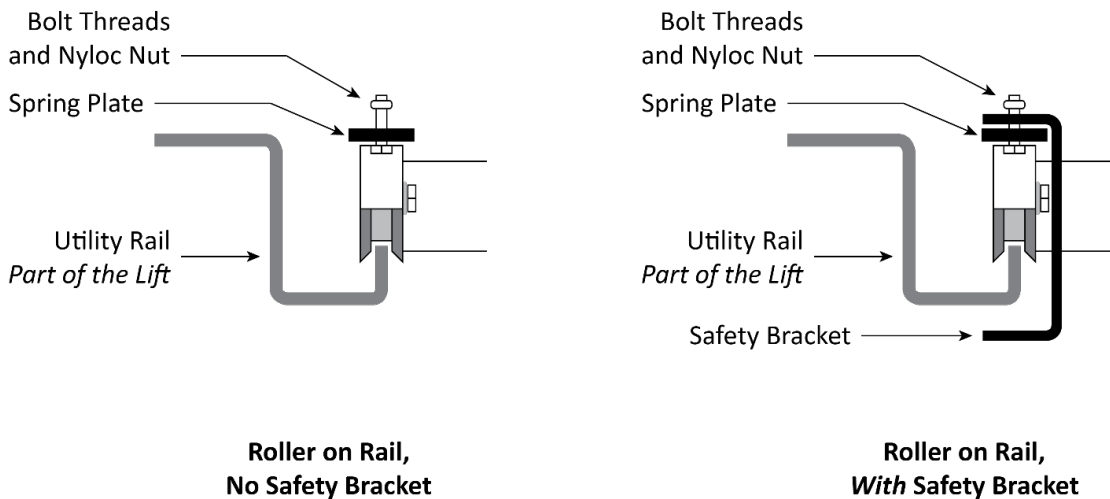

*Not to scale. Not all components shown. Side view. Shows a Roller without a Safety Bracket on the left and a Roller with a Safety Bracket on the right. **You must** install a Safety Bracket around each Roller.*

⚠ WARNING You are **required** to install a Safety Bracket around each of the four Rollers of the Rolling Jack. They ensure the Jack stays in place on the Utility Rails. If you do not install the Safety Brackets, there is a possibility the Rolling Jack could fall off the Lift, causing damage or injury.

- Securely tighten the Nyloc Nuts to hold the Safety Bracket in place.
- Install the Safety Brackets on the other three Rollers of the Rolling Jack.
- If you are installing **two** Jacks on the Lift: put the second Jack into place, securely tighten all four Adjustment Bolts, and then install all four Safety Brackets.
- Raise the Lift (so that the Rolling Jack is off the ground) and engage the Lift on a Safety Lock. If you engaged the Lift on a Safety Lock in Step 1, you pass this step.

⚠ WARNING Do not start using the Rolling Jack until you are certain the four-post Lift is engaged on its Safety Locks. If the four-post Lift is not engaged on its Safety Locks, it could move, impacting the stability of the Vehicle on the Rolling Jack, possibly causing it to fall off, and possibly causing damage or injury.

- Check the clearance around, and movement of, the Rolling Jack. Make sure the Rollers are centered in the Utility Rail Channel or on the Utility Rail Lip at all points along the usable portion of the Utility Rail.

- If necessary, make adjustments to ensure proper operation.

Do not use your Rolling Jack unless it is safe to do so!



IMPORTANT! PLEASE READ NOW



Hydraulic Fluid Contamination

Hydraulic Fluid Contamination poses a **serious** issue for your Lift; contaminants such as water, dirt, or other debris can migrate into the Hydraulic Hoses and Fittings on your Lift, making your new Lift inoperable and unusable. Your Lift is shipped with clean components; however, BendPak strongly recommends that you take secondary precaution and clean all Hydraulic Hoses and Fittings prior to making connections. It is better and less costly to take these extra steps now so that you do not need to take your Lift out of service later to fix issues that could have been prevented at the time of the installation.

There are several ways to clean Hydraulic Hoses and Fittings:











- **Compressed air.** Use an air compressor to blow out contaminants from each Hydraulic Hose and Fitting prior to installation. Clean, dry air is preferred. Wear eye protection (safety glasses, goggles, or face shield) when using compressed air for cleaning. Never point an air hose nozzle at any part of your body or any other person.
- **Fluid flushing.** As long as the Hydraulic Fluid is clean and compatible with the system fluid, you can flush Hoses and Fittings to create turbulent flow and remove particulates. Always ensure that the fluid itself is contaminant-free.

Some additional steps that will help keep the Hydraulic Fluid clean:

- **Remove old thread seal tape.** Some ports on the Hydraulic Cylinders are shipped with temporary plugs secured with thread seal tape, so make sure to thoroughly remove any leftover thread seal tape that may inadvertently enter the Hydraulic System.
- **Always use clean equipment.** If you use a dirty bucket or funnel to transfer the Hydraulic Fluid into the Hydraulic Fluid Reservoir, the contaminants will likely be introduced into the Fluid. When using cleaning rags, use a lint-free rag.
- **Proper storage.** Keep the Hydraulic Fluid sealed in its container until ready for use. Store the Fluid in a clean, dry, and cool area.
- **Cover the Hoses and Fittings.** Before installation, do not leave the ends of the Fittings exposed; the same applies for Hydraulic Hoses. As a general rule, keep the Hydraulic Hoses and Fittings capped and kept in a clean area until ready for use.
- **Filter the new Hydraulic Fluid.** Just because it is new does not mean it is *clean*. Use an offline filtration cart or kidney loop system to make sure the Hydraulic Fluid is clean before being transferred into the Reservoir (even using a heavy-duty nylon mesh screen is better than trusting what is left at the bottom of the barrel).
- **Avoid mixing different types of Hydraulic Fluid.** If Hydraulic Fluid needs to be replaced, make sure to flush the Hydraulic System of the old Hydraulic Fluid before you add the replacement fluid; do not mix the two together.

Hydraulic System Warnings

Before applying power to the Hydraulic System, note the following Warnings:

-  **DANGER** Failure to observe these warnings can result in serious personal injury including, in rare cases, death.
-  **WARNING** The Hydraulic hoses and connections **must** be inspected before using.
-  **WARNING** Verify all Hydraulic Hose connections and fittings, including unused auxiliary port plugs on the Power Unit, the Cylinder and anywhere else in the Hydraulic System are tightened.
-  **WARNING** The Power Unit is a Hydraulic Pump capable of developing pressures in excess of 5,000 psi (345 BAR). A pressure relief valve is used to set the pressure at the desired level. Tampering with, adjusting, modifying, or removing the relief valve is extremely dangerous and is not permitted. Only trained Hydraulics technicians are allowed make adjustments to the relief valve, using calibrated hydraulic pressure gauges to ensure the proper pressure setting is achieved.
-  **DANGER** Changes to the output pressure may render the power unit incompatible with pressure limitations of other components in the hydraulic circuit. This may cause catastrophic failure of those components, and could result in property damage, personal injury, or death.
-  **DANGER** The Hydraulic System can contain high pressure which, if suddenly released, can cause serious injury or death.
-  **WARNING** Do **not** attempt to connect or disconnect Hydraulic Hoses while the equipment is loaded or while a Vehicle is on the Lift, or the Hydraulic System is under pressure.
-  **WARNING** Keep bare hands away from Hydraulic Fluid; always wear gloves when handling Hydraulic Fluid, Cylinders or Hydraulic Hoses.
-  **WARNING** When handling Hydraulic Fluid, always observe the safety instructions.
-  **WARNING** **Always** promptly clean any Hydraulic Fluid spills. If a leak is the source of the spill, lockout the Lift to prevent use until the Hydraulic System is repaired.
-  **WARNING** Do **not** attempt to service the Power Unit through the rear panel. Only access the Power unit through the Front of the Console.

About Thread Sealants

Liquid Thread Sealant lubricates and fills the gaps between the Fitting threads and leaves no residue that could contaminate the Hydraulic Fluid. Other types of Thread Sealants (like Teflon Tape) can shred during installation or removal and eventually enter the Hydraulic System. Thread Sealant can be used with most Hydraulic Fittings, although you probably only need to use it with NPT connectors.

To apply Thread Sealant:

1. Apply the thread sealant when the ambient temperature is between +46.5°F to +70°F (+8°C to 21°C). Make sure the Fittings and connectors you are going to use are clean and dry.
2. If you are adding Thread Sealant to a Fitting or connector that has already been used with a different sealant, use a wire brush to thoroughly remove the old sealant before adding more.
3. Skipping the top thread, apply a small amount of Thread Sealant to the next four threads of the Fitting.

 **WARNING** Wear proper protective equipment with Thread Sealant.

Use a small amount as the sealant spreads to the other threads as it is tightened. If excess liquid escapes, use a rag to wipe away the excess.

4. Tighten the Fitting into the connector; do **not** over tighten.
5. Allow the manufacturer-recommended curing time before pressurizing the system.



Use a liquid thread sealant only. Teflon paste-type thread sealant or Loctite™ 5452 thread sealant is recommended for all NPT Fittings. Do not over tighten NPT Fittings or they may crack. Do not use thread seal tape on flare-end JIC 37-degree bevel Fittings or ORB O-Ring Fittings.

Setting Up the Air-Driven Hydraulic Pump

Your Rolling Jack is delivered with an Air-Driven, Hydraulic Pump, that provides hydraulic pressure to the Rolling Jack. It is your responsibility to supply air pressure to operate the Hydraulic Pump.

IMPORTANT! The Hydraulic Pump will run with either dry or lubricated compressed air. Lubricated air is preferred to extend the life of the internal pump components.

The Air-Driven Hydraulic Pump arrives with Hydraulic Fluid. You do not need to add any at this point unless Fluid has leaked. Checking the Hydraulic Fluid level is described in the next section.

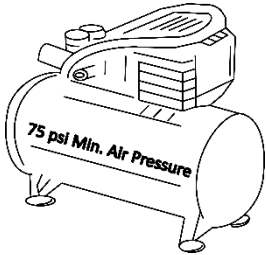
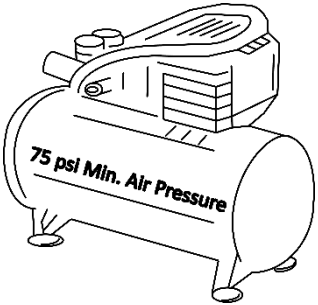
3 Levels of Suggested Air Compressors for Rolling Jack Operation				
Model Level	Service Size	Air Tank Volume	CFM	Minimum Operational PSI
Good		3 Gallon Min.	20 to 25	100 (Do Not exceed 125 psi)
Better		10 Gallon Min.	20 to 25	100 (Do Not exceed 125 psi)
Best		20 Gallon Min.	20 to 25	100 (Do Not exceed 125 psi)

Air pressure should be set to 20 cubic feet per minute (.57 cubic meters per minute) and 100 psi (7 bar) minimum. **The optionally available WSA-100 provides lubricated air to operate the pump**, while increasing service life and operation is recommended.

⚠ WARNING Do not exceed 125 psi (8.6 bar) at any time; you can damage the Air-Driven Hydraulic Pump.

⚠ WARNING Before performing installation or maintenance, release the pressure currently in the system by pressing and holding the Release End of the Pump pedal, then disconnect the Pump from its air pressure at the Air Intake Valve.

To set up your Air-Driven Hydraulic Pump:

1. Remove the thread protector from the Air Intake Valve.

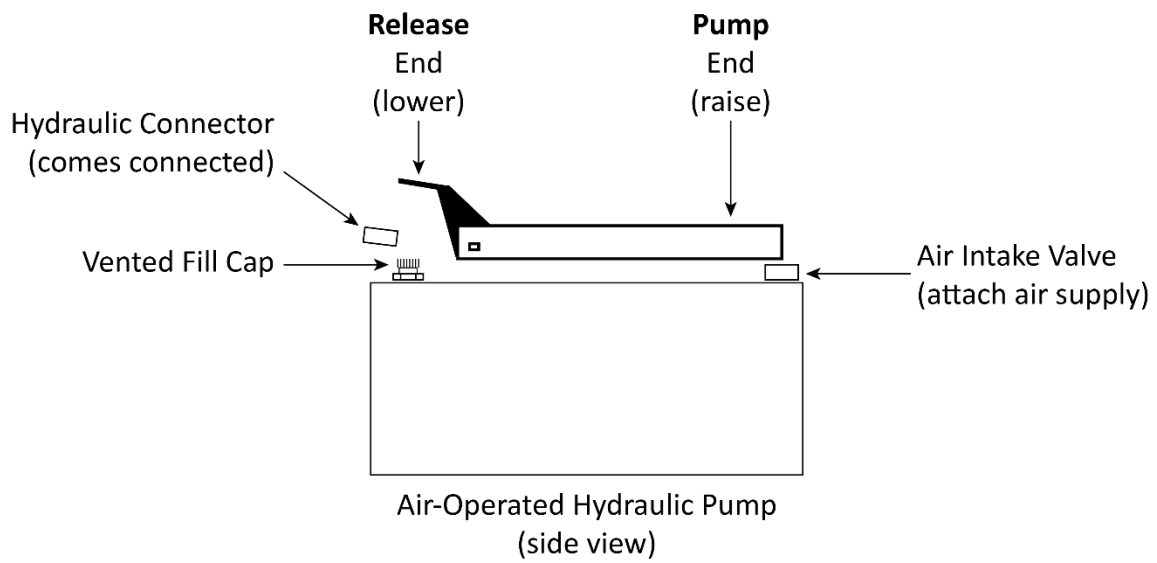

2. Install a threaded fitting (not supplied) that is compatible with your air supply into the Air Intake Valve.
3. Connect your air supply to the threaded fitting you just installed.

⚠ CAUTION An appropriate Air Line regulator and water separator (customer supplied) must be installed on the air supply. **Failure to install these items could lead to damage and voids the warranty on pneumatic components.**

4. The Vented Fill Cap is tightened for shipment; loosen it approximately one turn counterclockwise before starting normal operation.

Preparing for Operation

To prepare the Rolling Jack for normal operation, you need to:

- Make sure the fluid reservoir on the Air-Driven Hydraulic Pump has Hydraulic Fluid.
- Perform an operational test to make sure the Rolling Jack is working normally.

The fluid reservoir of your Rolling Jack was filled at the factory. Nevertheless, before using it, you should check the reservoir to make sure it still has Hydraulic Fluid.

⚠ CAUTION Do not run the Air-Driven Hydraulic Pump without fluid; you will damage it.

Approved fluids are any general purpose ISO-32, ISO-46, or ISO-68 Hydraulic Fluid or approved ATF fluids such as Dexron III, Dexron VI, Mercon V, Mercon LV, or any Synthetic Multi-Vehicle ATF.

To check the Hydraulic Fluid reservoir of the Air-Driven Hydraulic Pump:

1. Remove the Vented Fill Cap.
2. Insert a dipstick or piece of plastic into the tank until it hits the bottom.
3. Remove the dipstick or piece of plastic and measure the amount of fluid.
The fluid level should be from 3.375 to 3.5" (85 to 89 mm) deep. If the current level is below 3.375" , add approved fluid until it is between 3.35 and 3.5" (85 to 89 mm). If the current level is already between 3.375 and 3.5" (85 to 89 mm), no action needs to be taken.
4. Reinstall the Vented Fill Cap.

To test your Rolling Jack: You do not need a Vehicle on the Jack to test it.

⚠ DANGER Pinch and Crushing hazard. When raising or lowering your Jack, keep body parts, especially your hands, away from the Scissor Structure and the Adjustable Arms. You could be injured if you are not careful.

1. Press and hold the **PUMP** end of the pedal to begin raising the Rolling Jack.
2. When the Rolling Jack reaches the desired height, release the **PUMP** end.

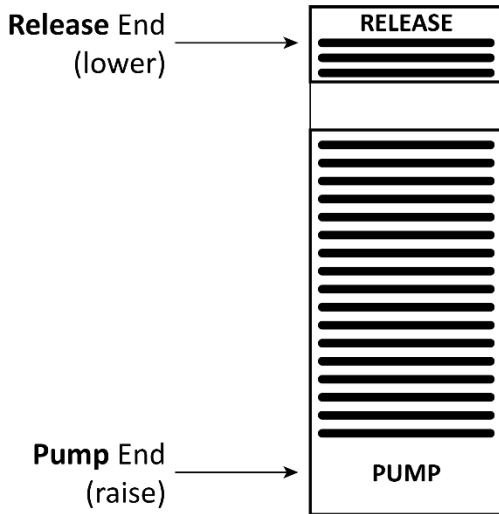

If the Rolling Jack does not raise, refer to the **Troubleshooting** section.

3. Press and hold the **RELEASE** end to lower the Rolling Jack down onto the nearest Safety Lock.
4. Release the **RELEASE** end of the pump when the Jack engages on the Safety Lock.

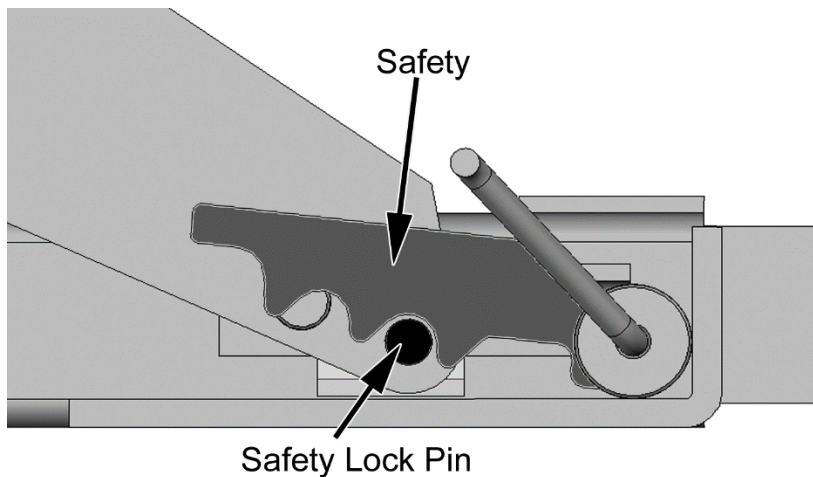

This drawing shows the Jack engaged on a Safety Lock; the Safety Lock is held in place on the Safety Lock Pin by the weight of the Vehicle on the Rolling Jack.

⚠ WARNING Only leave your Rolling Jack on a Safety Lock or fully lowered.

-
- To lower the Rolling Jack: press the **PUMP** end of the pedal to free it off the Safety Lock Pin, pull up on the Safety Handle to move the Safety Lock Pins out of the way, then press and hold the **RELEASE** end of the Pump.

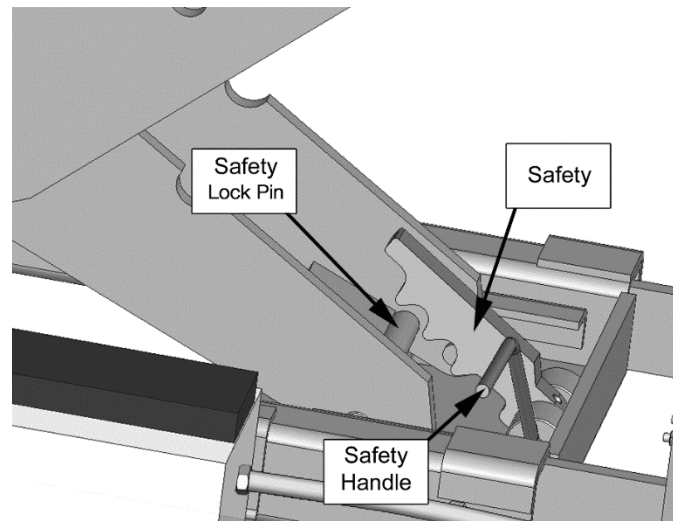

The Rolling Jack begins lowering.

- When the Jack is fully lowered, release the **RELEASE** end of the pedal.

Assuming the test was successful, your Rolling Jack is ready for normal operation.

If there were issues, resolve the issues before beginning normal operation. Refer to [Troubleshooting](#) for additional information.

Operation

This section covers normal operation of your Rolling Jack.

Important: Your safety is dependent on reading, understanding, and implementing these Safety Rules. **Do not skip over them; read them carefully and follow them!**

⚠ DANGER **Crushing hazard and pinch points.** Do not place any part of your body between the top deck and any moving part of the Rolling Jack unless visual confirmation is made that the safety lock is fully engaged, and that the Jack's downward motion is blocked by a Jack Stand, Forklift or other Load-Holding device that will prevent the Jack's downward movement while working under it.

To use your Rolling Jack safely:

- Never stand under or walk under a Rolling Jack when the Lift is raised, whether there is a Vehicle on the Jack or not. **Safety first: walk around!**
- Check daily to make sure all Rollers are setting correctly either **on** the Utility Rail Lip or **in** the Utility Rail Channel, depending on model. If one or more Rollers come off the Utility Rail Lip or out of the Utility Rail Channel, it could fall.

⚠ DANGER If you see any of the Rollers off the Utility Rail Lip, out of the Utility Rail Channel, or moving strangely, immediately move all persons away from the Lift and the Rolling Jack. When everyone is out of the way, carefully lower the Lift to the ground (if it is raised) and drive the Vehicle off (if there is a Vehicle on the Lift), as long as these things can be done safely. When the Lift is fully lowered, put the Rollers back onto the Utility Rail Lip or the Utility Rail Channel, then make sure the Adjustment Bolts and the Safety Brackets are installed and operating correctly. Do **not** put the Rollers back onto the Utility Rail Lip or into the Utility Rail Channel from underneath the Rolling Jack.

- After moving or using your Rolling Jack, check to make sure the Rollers are setting correctly either on the Utility Rail Lip or in the Utility Rail Channel.

⚠ WARNING Use care when using your Rolling Jack. If it falls when the Lift is raised, it can damage the Jack, the ground underneath, or cause significant injury to anyone underneath it. **BendPak strongly recommends no one, ever, walk underneath your Rolling Jack when the Lift is raised.**

- Always keep the Utility Rail Channels clean. If there are liquid spills, wipe them up. If there is debris, clean it up. If anything, other than the Rolling Jack is in the Utility Rail Channels, move those things.
- Before lowering the Lift, check underneath it to make sure there are no obstructions on the ground under the Rolling Jack. If there is something under the Rolling Jack, move it out of the way. The issue here is that if the Jack hits an obstruction on the ground, it could push the Jack out of position or off the Utility Rail, increasing the chances that it could fall.
- Before driving a Vehicle onto the Lift, make sure the Rolling Jack is **fully** lowered and the Lift Pads are removed; you do not want the underside of the Vehicle to contact any part of the Jack.
- Before and after driving a Vehicle onto the Lift, check to make sure the Rollers are setting correctly on the Utility Rail Lip or in the Utility Rail Channel, depending on model.
- If a Vehicle accidentally knocks the Rolling Jack when being driven either onto or off of the Lift, the Jack may no longer be secure. Check to make sure the Rollers are setting correctly on the Utility Rail Lip or in the Utility Rail Channel, the Adjustment Bolts and Safety Brackets are in place and operating normally, and the Rolling Jack is not damaged. If you find any of these situations, take the Jack out of service and fix the issues before resuming use of the Rolling Jack.

Raising and Lowering

This section describes how to raise and lower your Rolling Jack.

To raise a Vehicle on your Rolling Jack:

1. Drive the Vehicle onto the Lift.

⚠ WARNING Make sure the arms of the Rolling Jack are **fully lowered** and the Lift Pads are removed so they do not hit the underside of the Vehicle when the Vehicle is driven onto the Lift. If a Vehicle does hit the Rolling Jack while being driven onto or off of the Lift, make sure the Rolling Jack has not been damaged, that all Rollers are correctly seated on or in the Utility Rail, the Adjustment Bolts are in place and tightened, and the Safety Brackets are in place.

2. Position the tires of the Vehicle in the center of each Runway.
3. Set the parking brake on the Vehicle and use a wheel chock to hold the Vehicle in position.
4. Check the Utility Rail Channels to make sure nothing is in them that could obstruct the movement of the Rolling Jack.
5. Check the area to make sure everyone and everything is clear of the Lift and the Rolling Jack; make sure there are no obstructions above the Vehicle.
6. Position the Adjustable Arms of the Rolling Jack so the Lift Pads are under the Vehicle's axle housing or contact the Vehicle manufacturer for recommended lifting points.

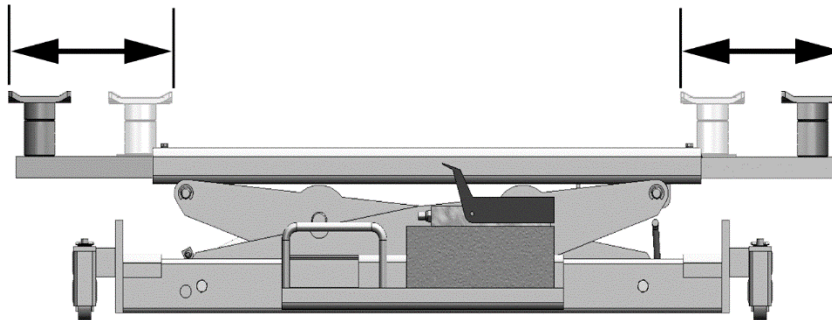

⚠ WARNING Make sure to raise the Vehicle on the axle housing or at the correct lifting points. Lifting at the wrong location could potentially damage the Vehicle and/or the Rolling Jack.

7. Press and hold the **PUMP** end of the pedal to begin raising the Rolling Jack.

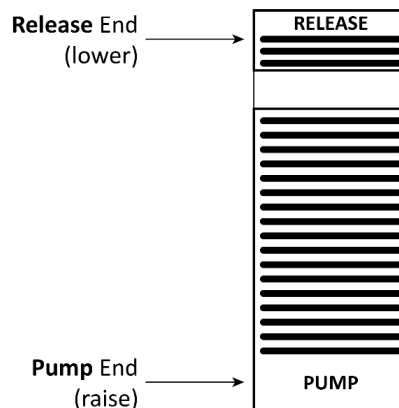

- When the Rolling Jack reaches the desired height, release the **PUMP** end, then press and hold the **RELEASE** end to lower the Rolling Jack onto the nearest Safety Lock.
- Release the **RELEASE** end of the pump when the Jack engages on the Safety Lock (it will stop moving down).

To lower a Vehicle:

⚠ DANGER **Crushing hazard and pinch points.** Do not place any part of your body between the top deck and any moving part of the Rolling Jack unless visual confirmation is made that the safety lock is fully engaged, and that the Jack's downward motion is blocked by a Jack Stand, Forklift or other Load-Holding device that will prevent the Jack's downward movement while working under it.

- Press the **PUMP** end of the pedal for about two seconds; this raises the arms a little, moving them off the Safety Locks.

It is difficult or impossible to move the Safety Handle out of the way if the Jack is still engaged on the Safety Locks.

- Pull the Safety Handle up out of the way, then press and hold the **RELEASE** end of the pedal.

The Rolling Jack begins lowering.

- When the Jack is fully lowered, release the **RELEASE** end of the pedal.

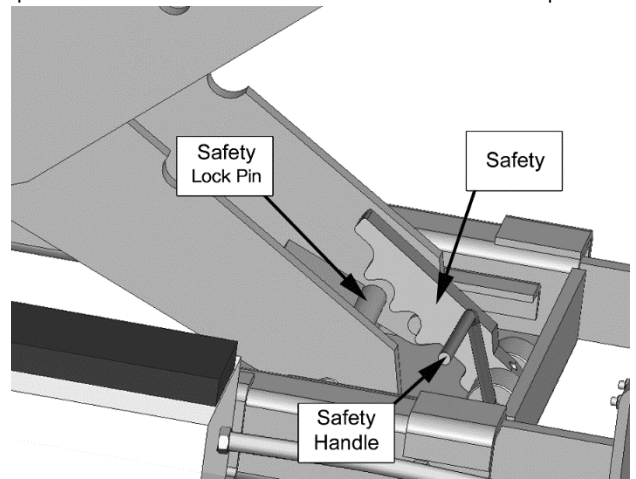

Moving a Rolling Jack

Tips for moving a Rolling Jack:

- Never** try to move a Rolling Jack if it has a Vehicle raised on it.
- The easiest way to move a Rolling Jack is to use its Moving Handle when the Lift is lowered, and no Vehicle is on the Lift.
- If you know what Vehicle you are going to be raising and there is approach clearance, move the Jack(s) to where the frame or chassis lift points will be **before** driving the Vehicle onto the Lift.
- Before moving a Rolling Jack, make sure the Rollers are setting correctly on the Utility Rail Lip or in the Utility Rail Channel, depending on model. Also, **make sure the Adjustment Bolts and Safety Brackets are installed and working correctly.**

⚠ WARNING The safest way to move a Rolling Jack is when the Lift is fully lowered, and no Vehicle is on the Rolling Jack or on the Lift. BendPak strongly recommends always moving your Rolling Jack with the Lift fully lowered.

- BendPak strongly recommends not walking underneath the Rolling Jack when the Lift is raised.

Additional Operating Information

Keep the following in mind when operating your Rolling Jack:

- Check the weight of a Vehicle before attempting to lift it. Do not guess. Never exceed the rated load capacity of the Rolling Jack.
- Lift Pads must **always** be used; make sure they are correctly positioned under the frame or chassis lift points of the Vehicle you are raising. Do not raise a load without the Lift Pads. Only the Lift Pads should touch the Vehicle.
- Visually inspect your Rolling Jack before each use. Do not use it if you find damage or severe wear. Make sure the Rollers are on or in the Utility Rails.
- Do not rock the Vehicle while it is raised or remove items that could cause excessive weight shift.
- Keep the Utility Rail Channels and Lips clean and free from debris.

Hydraulic Power System Warnings

 **DANGER** Failure to observe these precautions can result in serious personal injury, including, in rare cases, death.

- The Air-Driven Hydraulic Pump must be correctly connected to the Rolling Jack before raising a Vehicle or applying air pressure.
- Do not attempt to connect or disconnect hoses while a Vehicle is raised or while the hydraulic system is under pressure.
- Guard against dirt getting into the Air-Driven Hydraulic Pump.
- Keep bare hands away from the Hydraulic Fluid.
- When dealing with the Hydraulic Fluid, observe the safety instructions of the manufacturer.
- Use protective equipment (like safety goggles, protective gloves, suitable working clothes, safety boots, and so on) when dealing with the hydraulic system.
- If Hydraulic Fluid comes into contact with the eyes, enters your bloodstream, or is swallowed, seek immediate medical attention.

Maintenance

 **WARNING:** Before performing **any** maintenance, remove air pressure from the system, then disconnect the air pressure supply from the Air-Driven Hydraulic Pump.

To maintain your Rolling Jack:

- Keep the Rolling Jack clean; wipe up any oil spills. Do not let dirt enter into the hydraulic system.
- **Daily.** Make a visual inspection of all moving parts and check for damage or excessive wear. Replace any damaged or worn parts before equipment is put back into operation.
- **Daily.** Make sure the Safety Locks are in good operating condition. Do not use your Rolling Jack if the Safety Locks are damaged, excessively worn, or out of place.
- **Daily.** Inspect Lift Pads for damage or excessive wear. Replace as required with BendPak parts.
- **Weekly.** Check all hose connections, bolts, and pins to make sure they are properly mounted.
- **Weekly.** Check (and tighten, if necessary) the Cylinder Bolt.

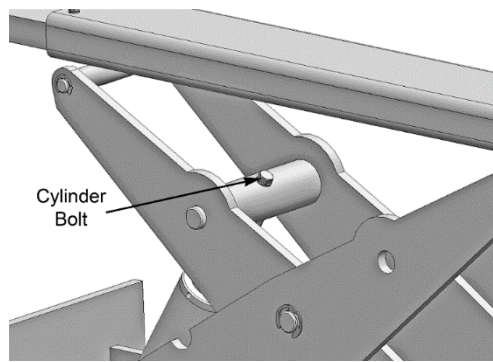

Every other month. Check the Air-Driven Hydraulic Pump fluid level and refill if required.

- **As needed.** Replace all caution, warning, and safety-related labels if illegible or missing.
- **As needed.** Reorder labels and worn or damaged parts from BendPak.
- **Weekly.** Lubricate all pivoting points.
- **Weekly.** Lubricate the Safety Lock pivot points.

Lubrication Procedure:

1. With a clean shop towel, wipe away dirt and old lubrication from pivot areas, Zerk fitting, and Pin Lubrication Hole.

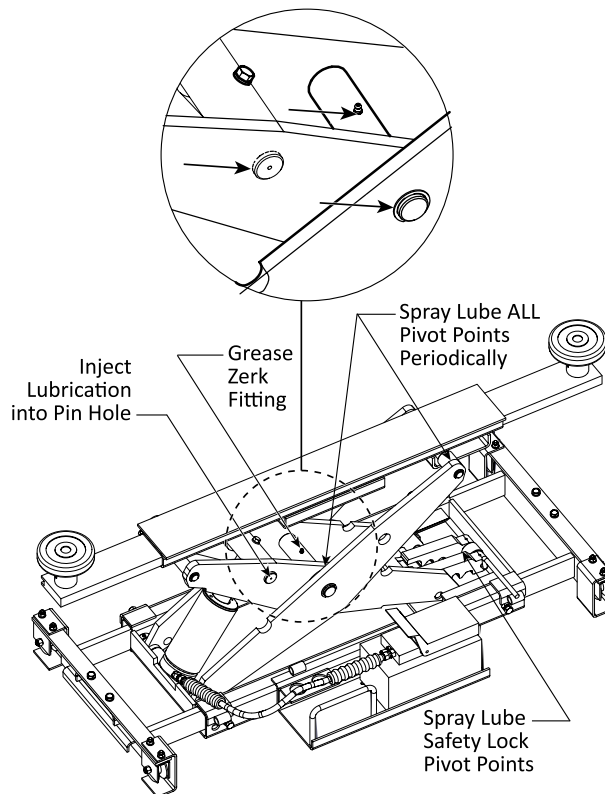

2. Apply Multi-Purpose White Lithium spray lubricant to all pivot points.
3. Inject Multi-Purpose White Lithium spray lubricant into Pin Lubrication Hole.
4. With an automotive type grease gun, pump Lithium multi-purpose grease into Zerk fitting until grease begins to slowly escape side areas.
5. Wipe away excess lubricant from Rolling Jack.

To maintain Hydraulic Fluid:

1. Remove the Vented Fill Cap.
2. Insert a dipstick or piece of plastic into the tank until it hits the bottom.
3. Remove the dipstick or piece of plastic and measure the amount of fluid.
The Hydraulic Fluid level should be from 3.35 to 3.5" deep.
4. If the current level is below 3.35" , add Hydraulic Fluid until it is between 3.35 to 3.5" .

Disposing of Hydraulic Fluid

Used Hydraulic Fluid cannot be thrown in the regular trash or dumped onto the ground or environment. This pollutes the environment and is generally illegal.

Instead, take the used to a recycling center. Used/dirty Hydraulic Fluid can be cleaned and re-used.

Important: If your Hydraulic Fluid is **contaminated** (by being mixed with other fluids such as antifreeze, gasoline, or solvents), you must treat it like hazardous waste and take it for disposal at an appropriate facility. Contaminated fluid is different than used/dirty.

In summary:

- If you have dirty/used Hydraulic Fluid, take it to a fluid recycling center, parts, or service facility.
- If you have contaminated Hydraulic Fluid, take it to a hazardous waste collection facility.

If you do not know how to find an appropriate facility, go to earth911.com or look for resources in your state or local area.

RJW Series Rolling Jack Lift Disposal - End of Service Life

Once your Lift has reached the end of its service life it must be disposed of properly. Metal recyclers will be able to advise on methods and costs to remove the Lift and will *reuse* the materials, diverting them from landfills. The best option is to contact a metal recycling center and discuss the size and weight of the Lift to determine if the facility can deconstruct and recover the usable components and metals.

The Hydraulic Cylinders, Hoses, Fittings, and the Power Unit itself must be disposed of in accordance with current national, state, and local regulations governing the use and disposal of hazardous materials. These components and any used Hydraulic Fluid **must not** be disposed of by dropping it into the trash or dumping it into the street. The Hydraulic Fluid contains toxic ingredients that are harmful to the environment.

These components and the Hydraulic Fluid are required to be recycled or must be delivered to a hazardous waste collection facility.

If you have substantial amounts of Hydraulic Fluid, consider contacting a commercial waste disposal company. In all cases, the best approach is to find an appropriate facility and contact them — in advance — to ask them: what kinds of fluids and materials they accept, what kind of containers it must be in, what hours they are open, their location, and any other information specific to their facility.

If you are unable to find an appropriate facility, the website earth911.com has resources that may be of help.

Troubleshooting

Issue	Action to Take
Jack does not lift load.	Make sure load is not too heavy. Make sure Rolling Jack is getting appropriate air pressure from the air supply. Make sure the Air-Driven Hydraulic Pump has sufficient Hydraulic Fluid and the hose is connected to the Rolling Jack. Make sure dirt has not gotten into the hydraulic system. If it has, replace the Hydraulic Fluid, and clean the hydraulic system.
Jack does not move along Utility Rail.	Make sure the Utility Rail Channels and Lips are clear of obstructions. Make sure the Rolling Jack is correctly situated on the Utility Rail Channel or Lip. Check with BendPak to make sure the Rolling Jack is installed on an approved Lift.
Jack raises load but does not stay up.	Make sure you put the Rolling Jack onto a Safety Lock when the load is at the desired height. The Rolling Jack is meant to raise and lower loads; it is not designed to hold a load indefinitely unless the load is on a Safety Lock. Make sure the Rolling Jack is not leaking Hydraulic Fluid.

If you continue to have issues with your Rolling Jack, take it out of service, then contact your dealer, go to bendpak.com/support, email support@bendpak.com, or call **(800) 253-2363**.

Accessories

Accessories available for the RJW Series of Rolling Jacks are described in this section.

Optional Air Line Kits

An **optional Air Line Kit** (AK-14) allows you to easily connect a compressed air source to the Rolling Jacks on your BendPak Four-Post Lift. One Air Line Kit provides the needed items to service *two* Rolling Jacks.

IMPORTANT! The Hydraulic Pump will run with either dry or lubricated compressed air. Lubricated air is preferred to extend the life of the internal pump components.

The figure below is a Top View of the **underside** of the Powerside Runway of a Four-Post Lift. It shows the path the incoming air takes through an **optional WSA Utility Station** that **provides lubricated air outlets**, through the Air Supply Connector, and on to each Rolling Jack Pump. Lubricated air improves the operation and performance of the Rolling Jack's pump; as compared to non-lubricated air. If no Utility Station is installed, air is connected to the incoming straight fitting. The top of the Runway is not shown.

Optional WSA-100 Utility Station

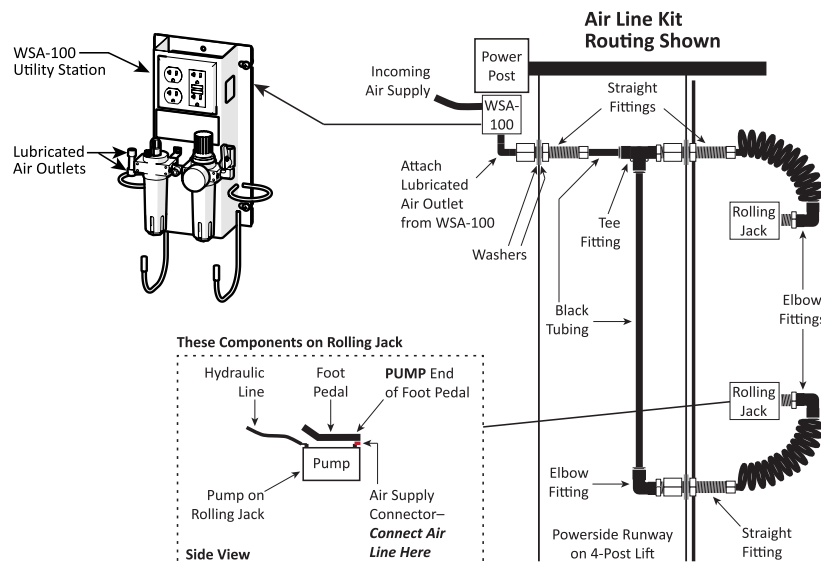

BendPak's **optional WSA-100 Utility Station** features lubricated air connections into the air supply and works to improve the performance and longevity of the hydraulic air pump.

There are four Air Line Kits available. Be sure to order the correct one for your Lift:

- **SKU 5174008.** For XR-12000A Lifts. Includes extra Fitting for use next to alignment turnplate.
- **SKU 5174009.** For HD-9, HD-12, HD-14, HDS-14, and HDSO-14 series four-post Lifts.
- **SKU 5174010.** For HDS-18 / 27 / 35 four-post Lifts.
- **SKU 5174011.** For HDS-27X / 35X / 40X four-post Lifts.

Visit [the website page for the Air Line Kit](#) for more information.

RJ45W Adapter Kit

The RJ45W Adapter Kit is a four-piece kit that increases the capabilities of the RJ45W Rolling Jack by providing sliding adapters that mount on the main center tube.

Note: This Adapter Kit **only works with the RJ45W** Rolling Jack; it cannot be used with other models.

The Adapter Kit includes:

- Two low-profile sliding rubber contact pads.
- Two sliding receivers that accommodate the standard RJ45W Lift Pads or stackable adapters.

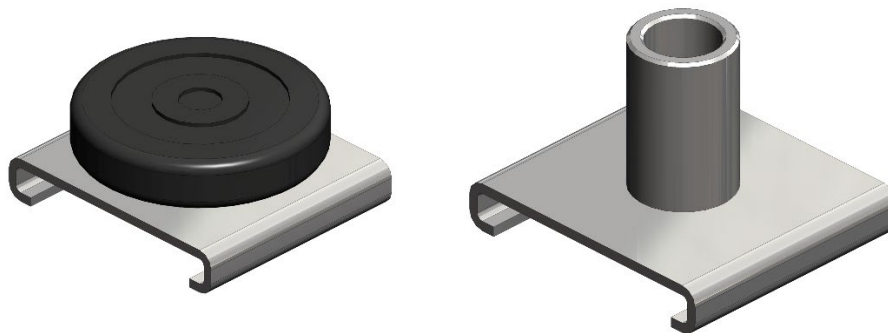

This image shows the short round Lift Pad on the left and the Lift Pad base on the right.

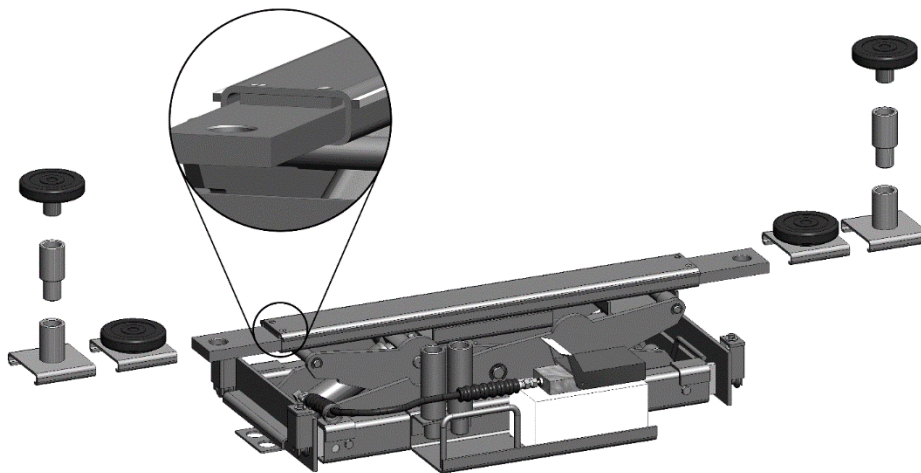

This image shows how to slide the adapters into place. You can adjust the positions of the adapters so that the Lift Pads make contact with the appropriate lifting points for the Vehicle you are lifting.

Visit [the website page for the Adapter Kit](#) for more information.

Labels

A

⚠ WARNING	<p>SERVICE REQUIREMENT EVERY 30-DAYS</p> <p>Keep entire jack and pump unit clean and free of debris. Lubricate both sides of all moving parts and pivot points on jack unit with multi-purpose lithium based grease, penetrating oil or 90-wt gear oil. Use enough lubrication to properly maintain all moving parts, but avoid over application. Apply silicone lubricant to smaller items such as handles and lock hinges. Always promptly remove excess grease and debris from</p>	<p>jack unit and pump unit. If you choose to have this equipment serviced by a service technician, always perform a personal inspection of all points to be sure nothing was overlooked. Warranty will be void on this equipment if service maintenance is not performed on a regular basis.</p>
------------------	--	--



P/N # 5905553

B

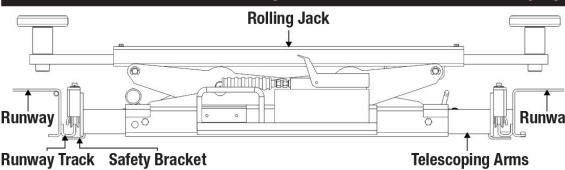
⚠ WARNING-PLEASE READ
<p>Read and understand all instructions before using this jack. Adjust rolling jack telescoping ends until rollers rest securely on runway tracks as shown. NEVER use rolling jack unless Safety Bracket is installed. REMAIN CLEAR of elevated rolling jack unless visual confirmation is made that jack rollers are secure on runway racks. BE CAREFUL WHEN ADJUSTING ROLLING JACK OR LIFT RUNWAYS to prevent rolling jack from becoming separated from runway tracks. Failure to read, understand and follow these instructions may cause death or serious injury.</p>
 <p style="font-size: x-small;">P/N # 5905253</p>

C

⚠ WARNING
<p>IMPROPER USE OF THIS ROLLING JACK MAY RESULT IN SERIOUS BODILY HARM!</p> <p>Always ensure that this rolling jack is positioned correctly on the runway rail assembly BEFORE raising the lift or working on or near the vehicle. KEEP HANDS CLEAR of all pinch points. NEVER use lift adapters other than those specifically designed for this jack.</p>

PN 5905190

D

⚠ WARNING	
<p>USE DRY AIR SOURCE ONLY</p> <p>Warranty will be void on this equipment if water contamination is found apparent. ALWAYS drain air compressor tank daily or use in-line dryer.</p> <p>SERVICE PARTS AND LABOR NOT COVERED UNDER WARRANTY IF RUST OR CORROSION IS PRESENT.</p>	<p>The pump unit on this jack was not designed to be used as a load holding device, jack must be raised to a locked position at all times.</p> <p>The manufacturer recommends installing an automatic air line oiler in the air inlet line as close to the pumping unit as possible. Air pressure must be regulated to 125 P.S.I. MAX. Pump unit must be kept clean to prevent contamination and pressure loss.</p>

PN 5905150

E

BP BendPak		Santa Paula, CA USA www.bendpak.com
MODEL NUMBER		
DESCRIPTION		
LIFT CAPACITY		
DATE CODE	SERIAL NUMBER	
⚠ DANGER!		
Disconnect Power Before Servicing		
CE EHC		UPC
MADE IN CHINA	WARRANTY VOID IF DATA PLATE IS REMOVED	PN 5905150

F

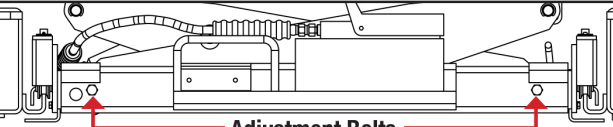
⚠ WARNING
<p>ALWAYS make sure rollers are properly positioned on runway utility rails and all ADJUSTMENT BOLTS are tightened before use or serious injury may result. READ PRODUCT MANUAL BEFORE USING THIS JACK.</p>
 <p style="font-size: x-small;">PN XXXXXX</p>

G

CALIFORNIA PROPOSITION 65

⚠ WARNING ⚠
WARNING! This product can expose you to chemicals including styrene and vinyl chloride which are on the list of over 900 chemicals identified by the State of California to cause cancer, birth defects or reproductive harm. ALWAYS use this product in accordance with the manufacturer's instructions. For more information, go to www.p65warnings.ca.gov. PN 5905775

PN 5905775

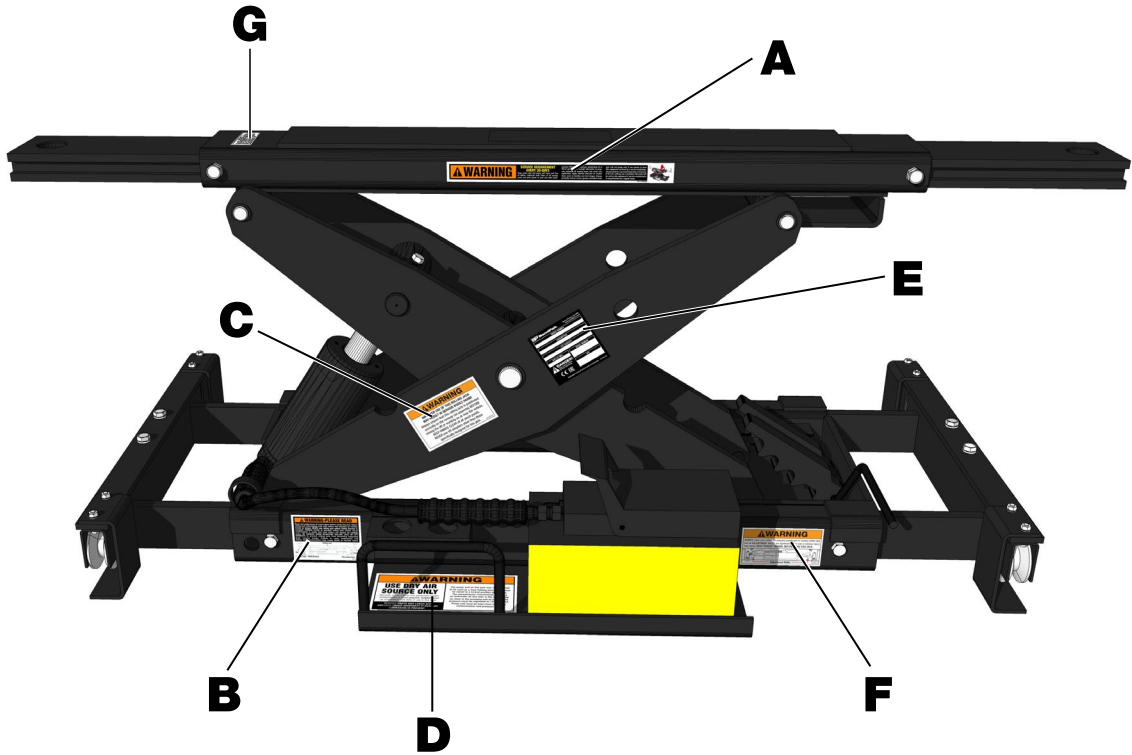

Parts Sheets

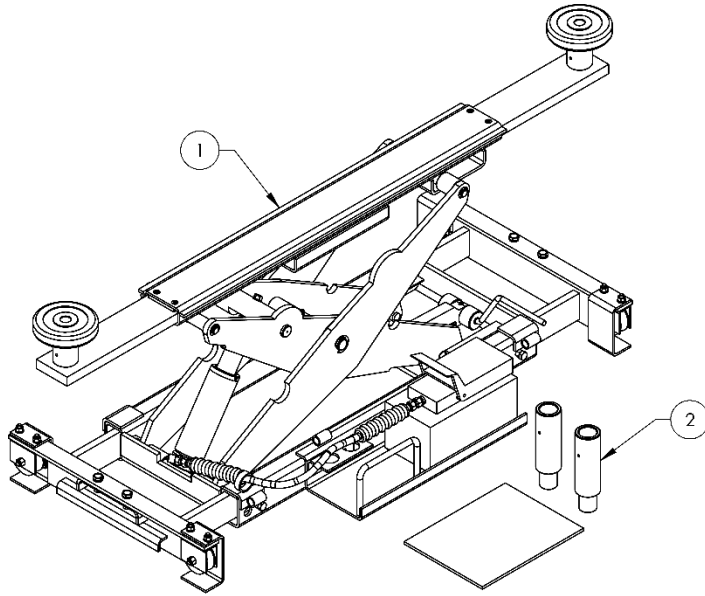

ITEM NO	PART NUMBER	DESCRIPTION	QTY	REV
1	5205013	RJ-45LP LIFT SUPERSTRUCTURE	1	C
2	5250271	DJ-4500/6000W, RJW PARTS BOX	1	F
-	5900093	RJW SERIES MANUAL	1	-

DO NOT SCALE DRAWING

NAME DATE
DRAWN CA 02/18/2020

BendPak.
1645 LEMONWOOD DR.
SANTA PAULA, CA 93060

CHECKED

DIMENSIONS ARE IN: MM

THIRD ANGLE PROJECTION

TITLE:
RJ-45LP PRODUCTION
LIFT VER E



PROPRIETARY AND CONFIDENTIAL
THIS DRAWING OR CONTAINED INFORMATION IS THE SOLE PROPERTY OF BENDPAK INC. ANY
REPRODUCTION OR TRANSMISSION OF THIS DRAWING OR INFORMATION WITHOUT
THE WRITTEN PERMISSION OF BENDPAK INC. IS
PROHIBITED.

SIZE DWG. NO.

A 5260610

REV

F

SCALE: 1:10

SHEET 1 OF 2

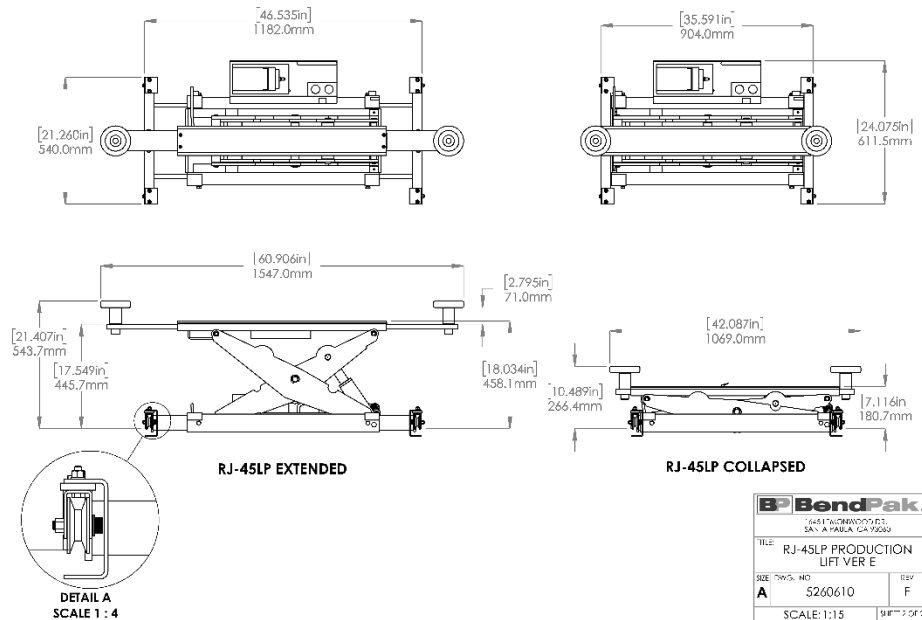

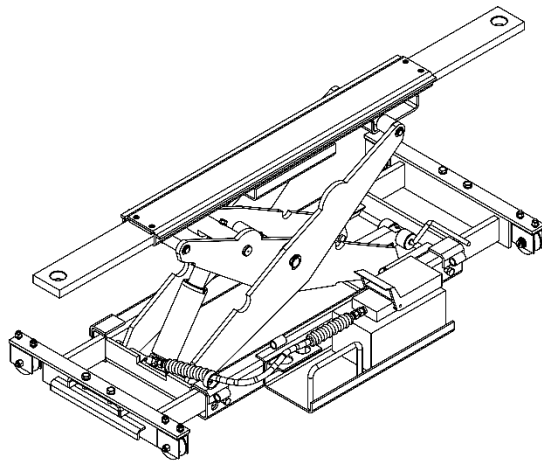

WHERE USED
RJ-45LP

NOTE: UNLESS OTHERWISE SPECIFIED

1. REFER TO MODEL FOR ADDITIONAL INFORMATION
2. SEE SHIPPING INSTRUCTIONS FOR FINAL PACKAGING ASSEMBLY ITEMS AS SHOWN
4. AIR HYDRAULIC PUMP MUST BE INSTALLED USING THE INCLUDED BOLTS

ITEM NO.	PART NUMBER	DESCRIPTION	QTY	REV
1	5600124	RJ-45LP MAIN BODY BASE WELDMENT	1	F
2	5502200	CYLINDER ASSEMBLY Ø2.0 x 4.375	1	G
3	5215111	RJ-45LP SCISSOR ASSEMBLY	1	F
4	5746031	RJ-45LP CYLINDER HINGE ROD	1	C
5	5215112	RJ-45LP EXTENSION ARM TUBE ASSEMBLY	1	G
6	5746035	RJ-45LP SCISSOR PIN ROLLER TUBE	1	C
7	5746034	RJ-45LP SCISSOR PIN	1	C
8	5746044	RJ45W SCISSOR CHANNEL SPACER	2	E
9	5746033	RJ 45LP SHORT SCISSOR PIN	1	C
10	5731122	RJ-45LP SAFETY HANDLE	1	C
11	5701072	RJ-45LP SAFETY HANDLE	1	C
12	5215697	RJW BASE ARM SPRING ROLLER PLATE ASSEMBLY	2	E
13	5570806	RJW SERIES HOSE ASSY Ø6.4mm x 600mm DS	1	E
14	5585732	AIR HYDRAULIC PUMP YELLOW RJ45W PSI-4600	1	B
15	5530132	HHB 3/8"-16 x 2-1/4" GR8/CL 10.9	1	-
16	5545130	WASHER 3/8" SL	1	-
17	5530788	HHB M10 x 1.5 x 2.5	4	-
18	5530054	SSS M10x1.5x12	1	-
19	5530055	SSS M6x1x10	2	-
20	5535013	NUT M10 x 1.5 NL	4	-
21	5540109	ERING Ø16mm OD DIN 6799 0160	4	-
22	5550493	FTG RST -04 JIC x -06 NPT x .062 ID	1	-
23	5550086	FTG ELB .04 NPT x .04 JIC	1	-

30 INCH SCALE DRAWING

DRAWN	CA	02/18/2020
CHECKED	CR	08/19/2022

BP BendPak®
1645 LEWIS WOOD DR.
SANTA PAULA, CA 93060

THIRD ANGLE PROJECTION

TITLE: RJ-45LP LIFT SUPERSTRUCTURE

SIZE DWG. NO. REV

A 5205013 C

SCALE: 1:10 SHEET 1 OF 2

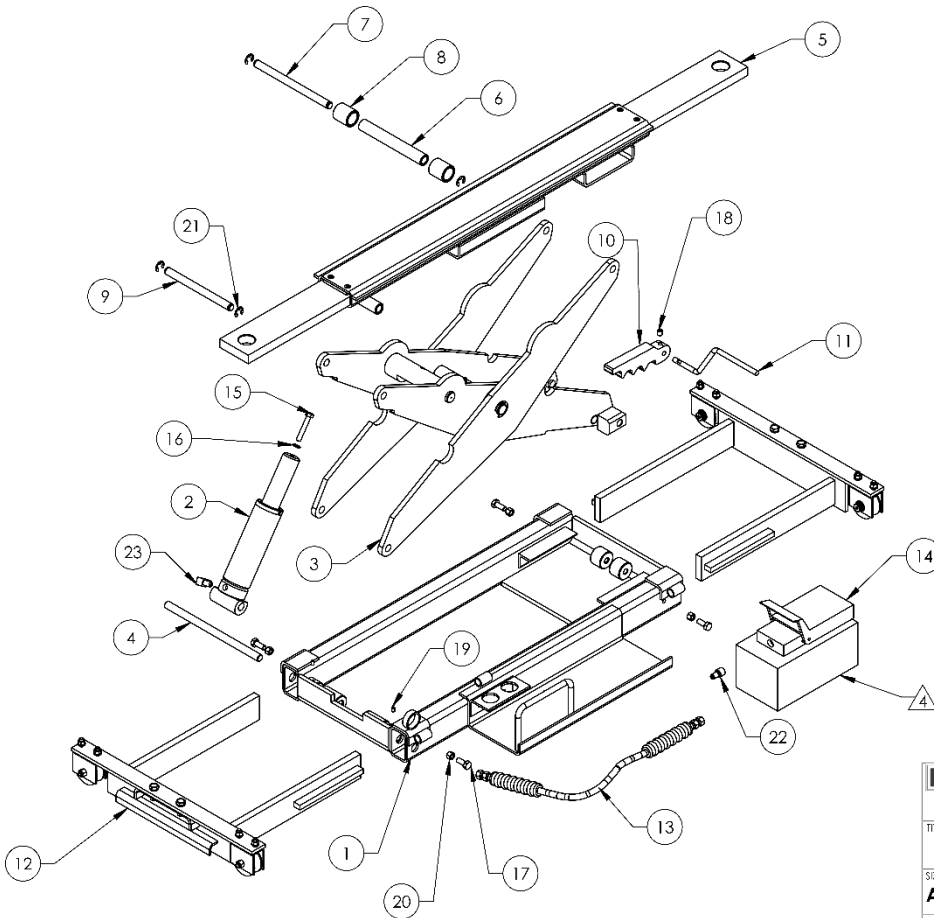

BP BendPak®		
1645 LEWIS WOOD DR. SANTA PAULA, CA 93060		
TITLE: RJ-45LP LIFT SUPERSTRUCTURE		
SIZE	DWG. NO.	REV
A	5205013	C
SCALE: 1:10		SHEET 2 OF 2

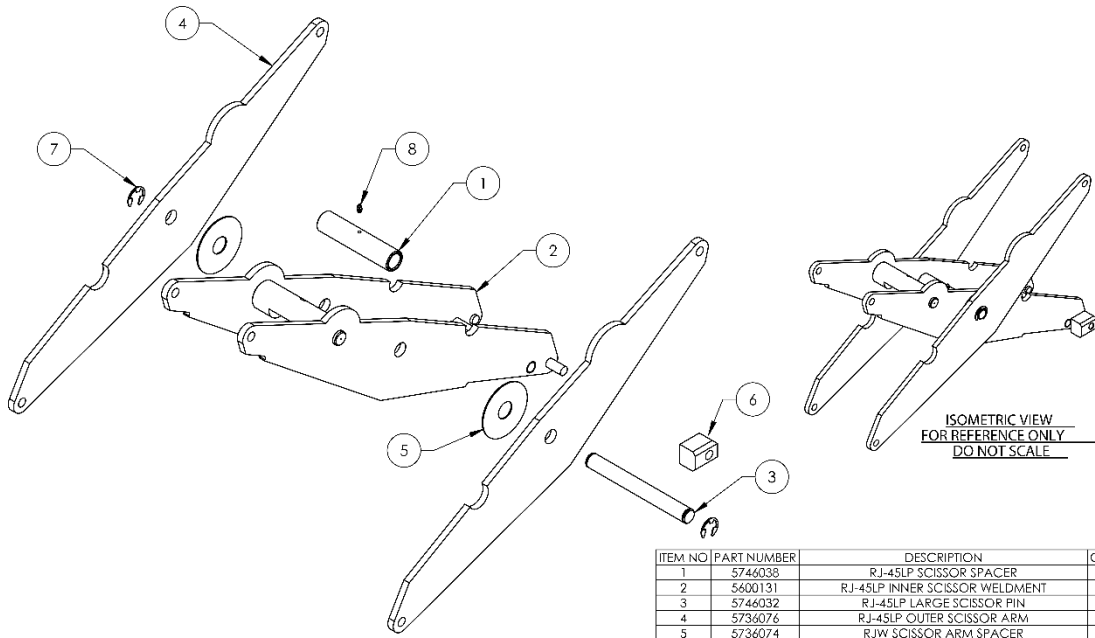

ISOMETRIC VIEW
FOR REFERENCE ONLY
DO NOT SCALE

ITEM NO	PART NUMBER	DESCRIPTION	QTY	REV
1	5746038	RJ-45LP SCISSOR SPACER	1	B
2	5600131	RJ-45LP INNER SCISSOR WELDMENT	1	D
3	5746032	RJ-45LP LARGE SCISSOR PIN	1	B
4	5736076	RJ-45LP OUTER SCISSOR ARM	2	C
5	5736074	RJ-45LP INNER SCISSOR ARM	2	D
6	5716007	RJ-45LP SCISSOR SLIDE BLOCK	2	B
7	5540275	E RING Ø25mm OD DIN 6799 0250	2	-
8	5550025	FTG GRS M6 x 1.0	1	-

DO NOT SCALE DRAWING	NAME	DATE	 BendPak 645 LEMONWOOD DR. SANTA PAULA, CA 93060
	DRAWN AC	01/04/2010	
	CHECKED OR	03/04/2020	
DMR:DC:IS:ABR:R:R&S	THIRD ANGLE PROJECTION		TITLE: RJ-45LP SCISSOR ASSEMBLY
 <small>PROPRIETARY AND CONFIDENTIAL THE INFORMATION CONTAINED HEREIN IS THE PROPERTY OF BENDPAK INC. AND IS TO BE USED ONLY FOR THE PURPOSES SPECIFIED BY THE DRAWING. THE ACCEPTANCE OF THIS INFORMATION BY THE USER IS THE SOLE RESPONSIBILITY OF THE USER.</small>	SIZE DWG. NO.		REV
	A 5215111		F
SCALE: 1:7			SHEET 1 OF 1

WHERE USED
RJ-45LP

NOTE: UNLESS OTHERWISE SPECIFIED
1. ASSEMBLE ITEMS AS SHOWN

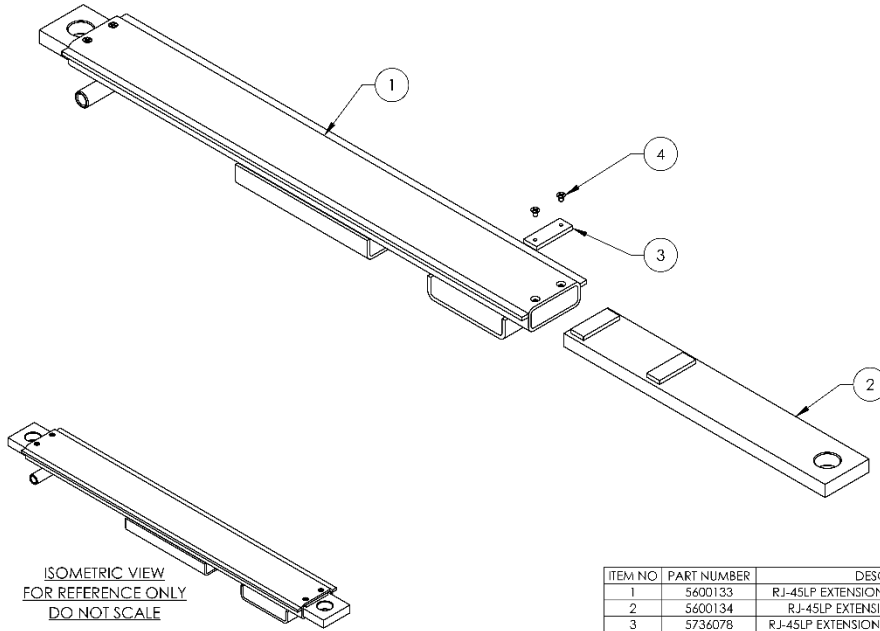

ISOMETRIC VIEW
FOR REFERENCE ONLY
DO NOT SCALE

ITEM NO	PART NUMBER	DESCRIPTION	QTY	REV
1	5600133	RJ-45LP EXTENSION ARM TUBE WELDMENT	1	E
2	5600134	RJ-45LP EXTENSION ARM WELDMENT	2	C
3	5736078	RJ-45LP EXTENSION ARM TUBE STOP BLOCK	2	C
4	5530058	FHPS M6 x 1.0 x 10	4	-

DO NOT SCALE DRAWING	NAME	DATE	 BendPak 645 LEMONWOOD DR. SANTA PAULA, CA 93060
	DRAWN AC	01/01/2009	
	CHECKED OR	03/04/2020	
DMR:DC:IS:ABR:R:R&S	THIRD ANGLE PROJECTION		TITLE: RJ-45LP EXTENSION ARM TUBE ASSEMBLY
 <small>PROPRIETARY AND CONFIDENTIAL THE INFORMATION CONTAINED HEREIN IS THE PROPERTY OF BENDPAK INC. AND IS TO BE USED ONLY FOR THE PURPOSES SPECIFIED BY THE DRAWING. THE ACCEPTANCE OF THIS INFORMATION BY THE USER IS THE SOLE RESPONSIBILITY OF THE USER.</small>	SIZE DWG. NO.		REV
	A 5215112		G
SCALE: 1:6			SHEET 1 OF 1

WHERE USED
RJ-45LP

NOTE: UNLESS OTHERWISE SPECIFIED
1. ASSEMBLE ITEMS AS SHOWN

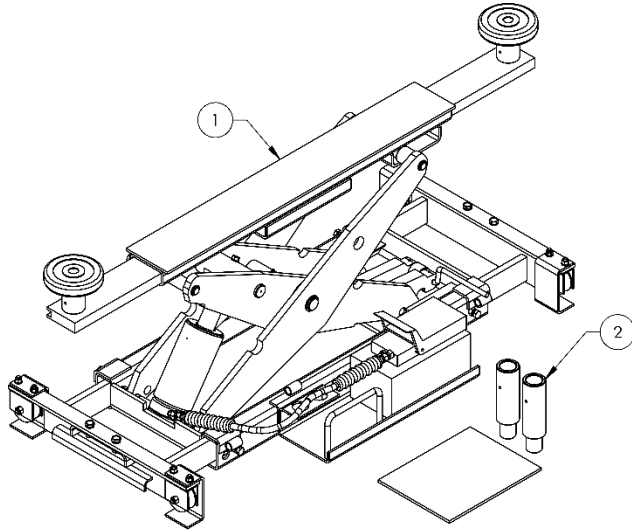

ITEM NO	PART NUMBER	DESCRIPTION	QTY	REV
1	5205008	DJ 4500 RJ45W LIFT SUPERSTRUCTURE	1	F
2	5250271	DJ-4500/6000W RJW PARTS BOX	1	F
-	5900093	RJW SERIES MANUAL	1	-

DC NOT SCALE DRAWING		NAME:	DATE	BendPak 1645 LEMONWOOD DR. SANTA PAULA, CA 93060
DRAWN	TM	11/09/2018		
DIMENSIONS ARE IN MM.		THIRD ANGLE PROJECTION		TITLE: RJ45W PRODUCTION LIFT VER F
				SIZE DWG. NO. REV
		PROPRIETARY AND CONFIDENTIAL <small>DO NOT DISSEMINATE OUTSIDE OF BENDPAK INC. WITHOUT WRITTEN PERMISSION FROM BENDPAK INC. ALL RIGHTS RESERVED. © 2018 BENDPAK INC.</small>		A 5260194 K
			SCALE: 1:10	SHEET 1 OF 2

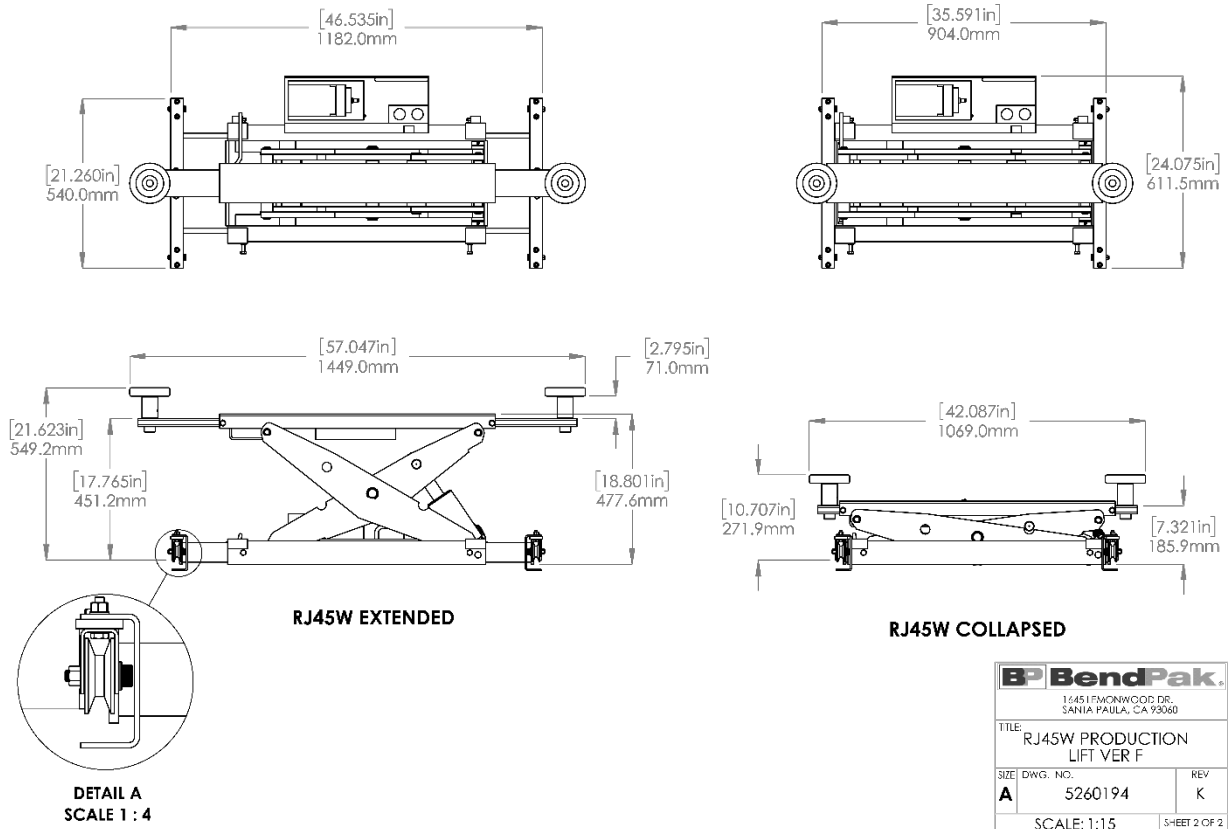

BendPak	
1645 LEMONWOOD DR. SANTA PAULA, CA 93060	
TITLE: RJ45W PRODUCTION LIFT VER F	
SIZE DWG. NO. REV	
A 5260194 K	
SCALE: 1:15 SHEET 2 OF 2	

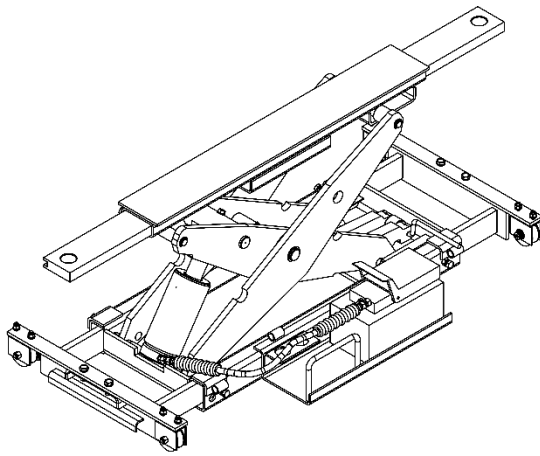

WHERE USED
DJ-4500
RJ45W

NOTE: UNLESS OTHERWISE SPECIFIED

1. REFER TO MODEL FOR ADDITIONAL INFORMATION
2. SEE SHIPPING INSTRUCTIONS FOR FINAL PACKAGING ASSEMBLE ITEMS AS SHOWN
3. ASSEMBLE ITEMS AS SHOWN
4. AIR HYDRAULIC PUMP MUST BE INSTALLED USING THE INCLUDED BOLTS

ITEM NO.	PART NUMBER	DESCRIPTION	QTY	REV
1	5601287	RJ45W MAIN BODY BASE WELDMENT	1	D
2	5502012	CYLINDER ASSEMBLY Ø3.0 x 4.375	1	F
3	5215809	RJ45W SCISSOR ASSEMBLY	1	B
4	5716045	RJ45W SCISSOR SLIDE BLOCK	2	A
5	5746374	RJW CYLINDER HINGE ROD	1	D
6	5215428	RJ45W EXTENSION ARM TUBE ASSEMBLY	1	F
7	5746377	RJW SCISSOR PIN ROLLER TUBE	1	C
8	5746376	RJW SCISSOR PIN	1	B
9	5746044	RJ45W SCISSOR CHANNEL SPACER	2	E
10	5746375	RJW SHORT SCISSOR PIN	1	B
11	5731039	RJW SAFETY LATCH	2	H
12	5701137	RJ45W SAFETY HANDLE	1	F
13	5215697	RJW BASE ARM SPRING ROLLER PLATE ASSEMBLY	2	E
14	5570806	RJW SERIES HOSE ASSY Ø6.4mm x 600mm DS	1	E
15	5585732	AIR HYDRAULIC PUMP YELLOW RJ45W PSI-4600	1	B
16	5530132	HHB 3/8"-16 x 2-1/4" GR8/CL 10.9	1	---
17	5545130	WASHER 3/8" SL	1	---
18	5530302	HHB M10 x 1.5 x 40 FULLY THREAD	4	---
19	5530790	SSS M6 x 1 x 10 NL	4	---
20	5535998	NUT M10 x 1.5	4	---
21	5540109	E RING Ø16mm OD DIN 6799 0160	4	---
22	5550493	FTG RST-04 JIC x -06 NPT x .062 ID	1	---
23	5550038	FTG 45ELB-04 JIC x -04 NPT	1	---

DO NOT SCALE DRAWING

NAME	DATE	
DRAWN	11/28/2019	
CHK'D	08/19/2022	1645 LEMONWOOD DR. SANTA PAULI, CA 93060
EMISSION SCALE: 1:10	1:10	TITLE: DJ-4500, RJ45W LIFT SUPERSTRUCTURE SIZE: DWG. NO. 5205008 REV F SCALE: 1:10 SHEET 1 OF 2

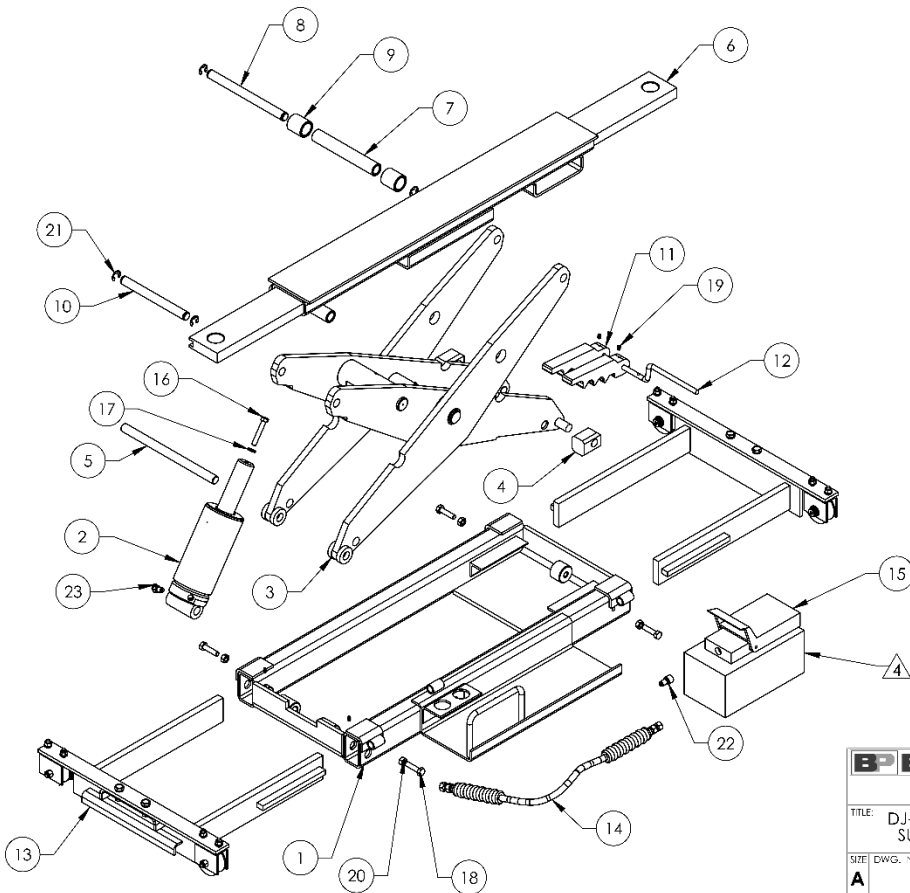

BendPak

1645 LEMONWOOD DR.
SANTA PAULI, CA 93060

TITLE: DJ-4500, RJ45W LIFT SUPERSTRUCTURE

SIZE: DWG. NO. 5205008 REV F

SCALE: 1:10 SHEET 2 OF 2

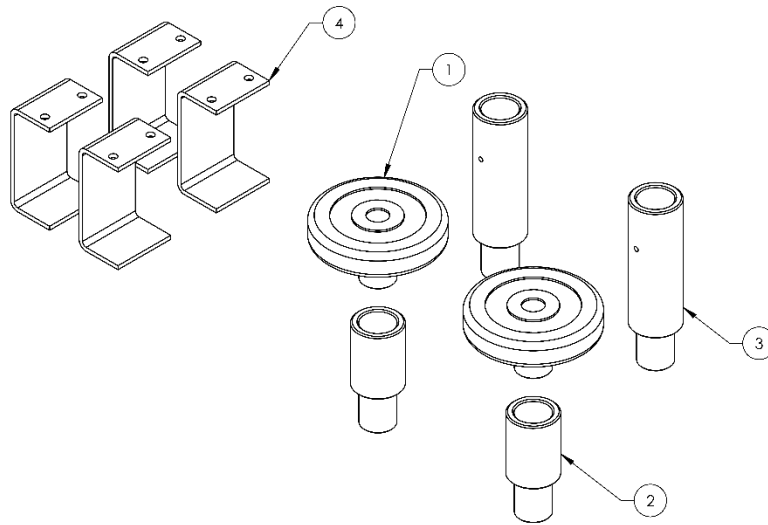

WHERE USED
DJ-4500
DJ-6000W
RJ-45LP
RJ45W
RJ6W
RJ7W

ITEM NO.	PART NUMBER	DESCRIPTION	QTY	REV
1	5215507	ROUND LIFT PAD ADAPTER ASSEMBLY	2	G
2	5746390	MEDIUM LIFT PAD EXTENSION Ø35 x 113mm	2	E
3	5746395	LONG LIFT PAD EXTENSION Ø35 x 182mm	2	D
4	5701543	RJW SPRING PLATE SAFETY BRACKET	4	D

DO NOT SCALE DRAWING	NAME	DATE	
DRAWN	IS	12/04/2017	
CHECKED	ON	04/12/2021	1645 LEMONWOOD DR. SANTA PAULA, CA 93080
THIRD ANGLE PROJECTION			TITLE: DJ-4500/6000W, RJW PARTS BOX
PROPRIETARY AND CONFIDENTIAL THE INFORMATION CONTAINED HEREIN IS THE PROPERTY OF BENDPAK INC. IT IS TO BE USED ONLY FOR THE PURPOSES SPECIFIED BY THE USER.			SIZE DWG. NO. REV A 5250271 F
SCALE: 1:4			SHEET 1 OF 1

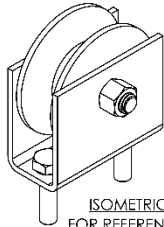

ISOMETRIC VIEW
FOR REFERENCE ONLY
DO NOT SCALE

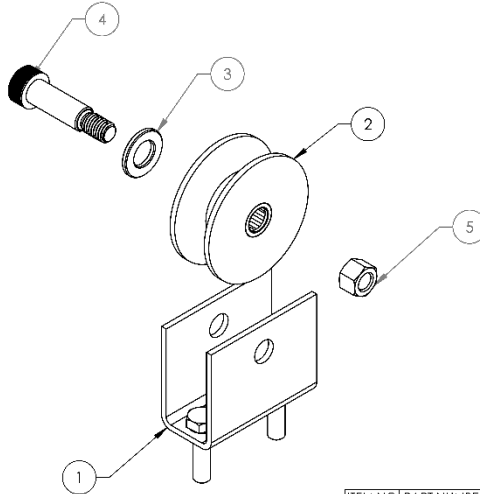

WHERE USED
RJ-45LP
RJ45W
RJ6W
RJ7W

NOTE: UNLESS OTHERWISE SPECIFIED
1. ASSEMBLE ITEMS AS SHOWN

ITEM NO.	PART NUMBER	DESCRIPTION	QTY	REV
1	5601393	RJW ROLLER BRACKET WELDMENT	1	A
2	5575040	RJW ROLLER ASSEMBLY	1	C
3	5545347	WASHER, M12 FLAT WASHER	1	--
4	5530370	SHSS M10 x 1.50 x 32mm SHOULDER	1	--
5	5535013	NUT M10 x 1.5 NL	1	--

DO NOT SCALE DRAWING	NAME	DATE	
DRAWN	IS	12/08/2017	
CHECKED	ON	03/04/2020	545 LEMONWOOD DR. SANTA PAULA, CA 93080
THIRD ANGLE PROJECTION			TITLE: RJW ROLLER BRACKET ASSEMBLY
PROPRIETARY AND CONFIDENTIAL THE INFORMATION CONTAINED HEREIN IS THE PROPERTY OF BENDPAK INC. IT IS TO BE USED ONLY FOR THE PURPOSES SPECIFIED BY THE USER.			SIZE DWG. NO. REV A 5210165 E
SCALE: 1:2			SHEET 1 OF 1

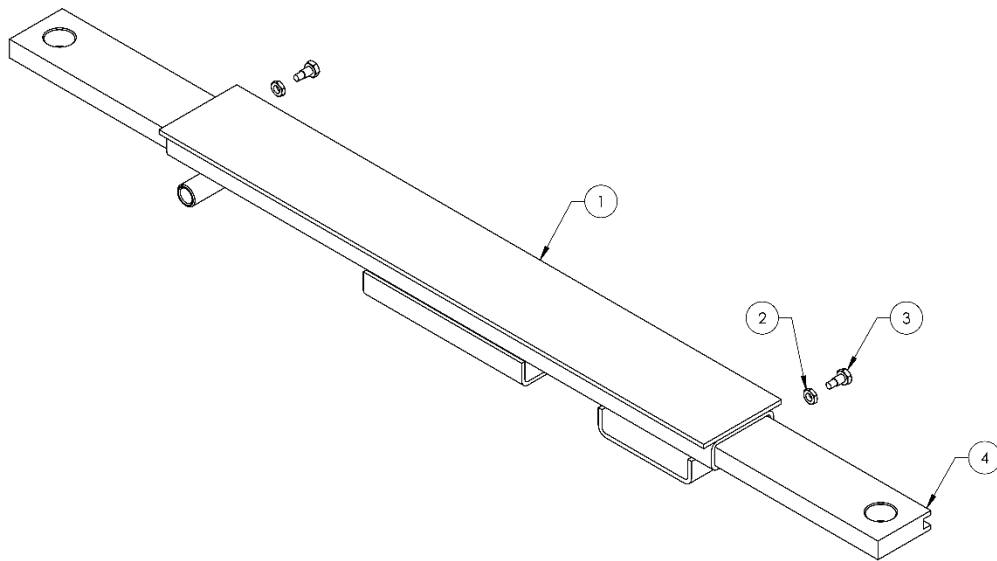

WHERE USED	
RJ45W	
RBJ4500 BYB	

ITEM NO	PART NUMBER	DESCRIPTION	QTY	REV
1	5601034	RJ45W UPPER ARM RECEIVER TUBE WELDMENT	1	F
2	5535035	NUT M10 x 1.5 JN	2	--
3	5530283	HEX BOLT M10 EXTENDED POINT	2	A
4	5736909	RJ45W EXTENSION ARM	2	D

DO NOT SCALE DRAWING	NAME	DATE	 1645 LEMONWOOD DR. SANTA PAULA, CA 93060
	DRAWN: IM	08/24/2013	
	CHECKED: CA	01/28/2019	
DIMENSIONS ARE IN: INCH	THIRD ANGLE PROJECTION		TITLE: RJ45W EXTENSION ARM TUBE ASSEMBLY SIZE: DWG. NO.: 5215428 REV: F
			SCALE: 1:5 SHEET 1 OF 1

NOTE: UNLESS OTHERWISE SPECIFIED
 1. ASSEMBLE ITEMS AS SHOWN

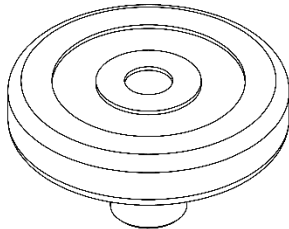

ISOMETRIC VIEW
 FOR REFERENCE ONLY
 DO NOT SCALE

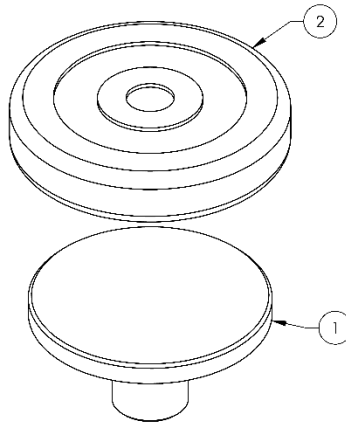

WHERE USED	
QUICKJACK SERIES	MAXJAX
P9000 SERIES	D2-10 SERIES
MD-6XP	DMR-6
DMR-6	D2-8F
SP-7XE SERIES	HD-78XT ACCY
GP-7 SERIES	
RJ-45LP	
RJW SERIES	
RBJ7000A	

NOTE: UNLESS OTHERWISE SPECIFIED
 1. SEE SHIPPING INSTRUCTIONS FOR FINAL PACKAGING
 2. ASSEMBLE ITEMS AS SHOWN

ITEM NO	PART NUMBER	DESCRIPTION	QTY	REV
1	5600588	ROUND LIFT PAD WELDMENT	1	C
2	5715017	ROUND LIFT PAD ADAPTER POLYURETHANE PAD	1	E

DO NOT SCALE DRAWING	NAME	DATE	 1645 LEMONWOOD DR. SANTA PAULA, CA 93060
	DRAWN: AC	12/30/2010	
	CHECKED: CA	06/18/2018	
DIMENSIONS ARE IN: INCH	THIRD ANGLE PROJECTION		TITLE: ROUND LIFT PAD ADAPTER ASSEMBLY SIZE: DWG. NO.: 5215507 REV: G
			SCALE: 1:2 SHEET 1 OF 1

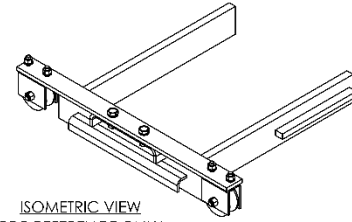
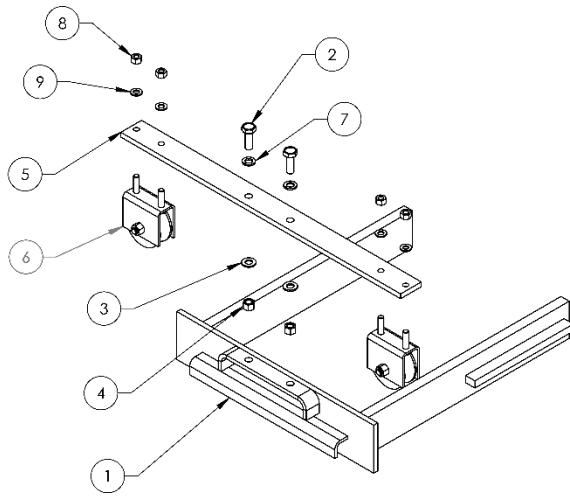

ISOMETRIC VIEW
FOR REFERENCE ONLY
DO NOT SCALE

WHERE USED
RJ45LP
RJ45W
RJ7W

- NOTE: UNLESS OTHERWISE SPECIFIED**
- SEE SHIPPING INSTRUCTIONS FOR FINAL PACKAGING
 - ASSEMBLE ITEMS AS SHOWN

ITEM NO	PART NUMBER	DESCRIPTION	QTY	REV
1	5620292	RJW BASE EXTENSION ARM SPRING ROLLER PLATE WELDMENT	1	C
2	5530021	HHB, M10 x 1.5 x 30	2	-
3	5545341	WASHER M10 x Ø20 FLAT	2	-
4	5535013	NUT M10 x 1.5 NL	2	-
5	5737039	RJW SPRING PLATE	1	D
6	5210165	RJW ROLLER BRACKET ASSEMBLY	2	E
7	5545200	WASHER M10 x Ø18 SL	2	-
8	5535001	NUT M8 x 1.25 NL	4	-
9	5545012	WASHER, M8x1.6x1.6mm FLAT	4	-

DO NOT SCALE DRAWING	NAME	DATE	BP BendPak 1645 LEMONWOOD DR. SANTA PAULA, CA 93060
	DRAWN TS	12/04/2017	
	CHECKED CR	03/04/2020	
DIMENSIONS ARE IN MM	THIRD ANGLE PROJECTION		TITLE: RJW BASE ARM SPRING ROLLER PLATE ASSEMBLY
☺	PROPRIETARY AND CONFIDENTIAL THIS INFORMATION IS UNCLASSIFIED UNLESS INDICATED OTHERWISE REPRODUCTION IN WHOLE OR IN PART IS PROHIBITED WITHOUT THE WRITTEN PERMISSION OF BENDPAK INC. ©		SIZE DWG. NO. REV
	A 5215697		E
SCALE: 1:6			SHEET 1 OF 1

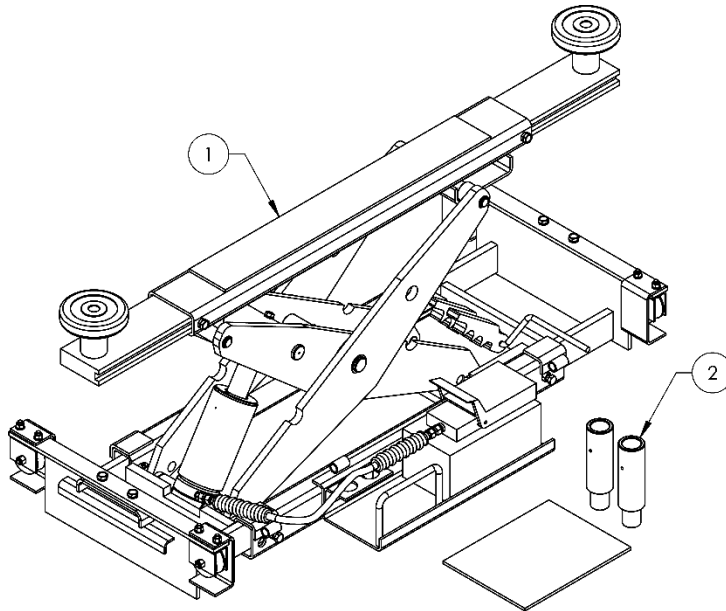

WHERE USED
XR-12000L
XR-12000AL

ITEM NO	PART NUMBER	DESCRIPTION	QTY	REV
1	5205010	RJ6W LIFT SUPERSTRUCTURE	1	E
2	5250271	DJ-4500/6000W, RJW PARTS BOX	1	F
-	5900093	RJW SERIES MANUAL	1	-

DO NOT SCALE DRAWING	NAME	DATE	BP BendPak 1645 LEMONWOOD DR. SANTA PAULA, CA 93060
	DRAWN TS	12/04/2018	
	CHECKED		
DIMENSIONS ARE IN MM	THIRD ANGLE PROJECTION		TITLE: RJ6W PRODUCTION LIFT VER E
☺	PROPRIETARY AND CONFIDENTIAL THIS INFORMATION IS UNCLASSIFIED UNLESS INDICATED OTHERWISE REPRODUCTION IN WHOLE OR IN PART IS PROHIBITED WITHOUT THE WRITTEN PERMISSION OF BENDPAK INC. ©		SIZE DWG. NO. REV
	A 5260283		J
SCALE: 1:10			SHEET 1 OF 2

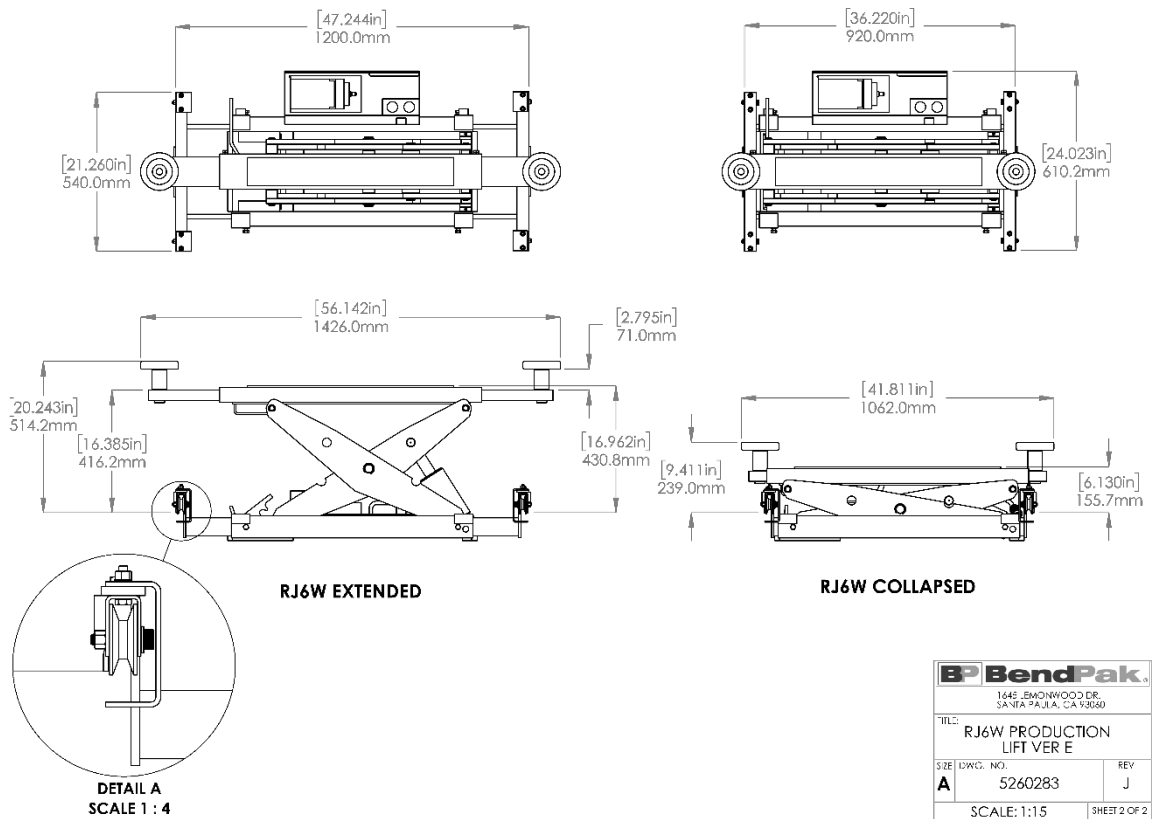

BendPak
1645 ELMWOOD DR.
SANTA PAULA, CA 93060

TITLE: **RJ6W PRODUCTION LIFT VER E**

SIZE DWG. NO. **A 5260283** REV **J**

SCALE: 1:15 SHEET 2 OF 2

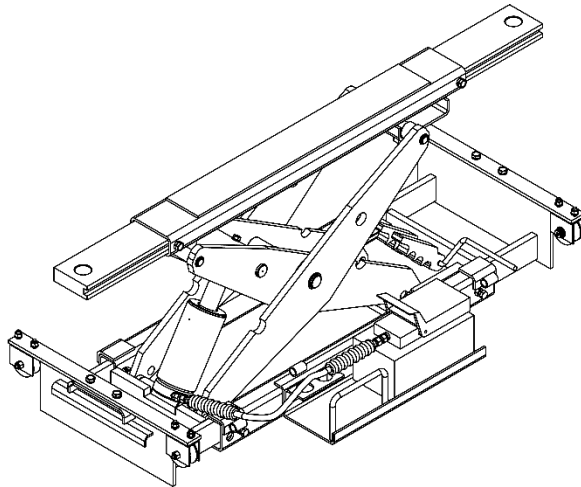

WHERE USED
RJ6W

NOTE: UNLESS OTHERWISE SPECIFIED

1. REFER TO MODEL FOR ADDITIONAL INFORMATION
2. SEE SHIPPING INSTRUCTIONS FOR FINAL PACKAGING ASSEMBLY ITEMS AS SHOWN
3. ASSEMBLE ITEMS AS SHOWN
4. AIR HYDRAULIC PUMP MUST BE INSTALLED USING THE INCLUDED BOLTS

ITEM NO	PART NUMBER	DESCRIPTION	QTY	REV
1	5601031	RJW MAIN BODY BASE WELDMENT	1	G
2	5215439	RJW SCISSOR ASSEMBLY	1	J
3	5746374	RJW CYLINDER HINGE ROD	1	D
4	5701136	DJ 6000W, RJ6W/7W/9W SAFETY HANDLE	1	G
5	5731039	RJW SAFETY LATCH	2	H
6	5210138	RJW EXTENSION ARM TUBE ASSEMBLY	1	C
7	5746378	RJW SCISSOR CHANNEL SPACER	2	B
8	5746377	RJW SCISSOR PIN ROLLER TUBE	1	C
9	5746376	RJW SCISSOR PIN	1	B
10	5746375	RJW SHORT SCISSOR PIN	1	B
11	5502012	CYLINDER ASSEMBLY Ø3.0 x 4.375	1	F
12	5570806	RJW SERIES HOSE ASSY Ø6.4mm x 600mm DS	1	E
13	5530302	HHB M10 x 1.5 x 40 FULLY THREAD	4	--
14	5530790	SSS M6 x 1 x 10 NL	4	--
15	5540109	E RING Ø16mm OD DIN 6799 0160	4	--
16	5545130	WASHER 3/8" SL	1	--
17	5550493	FIC RST -04 JIC x -06 NPT x .062 ID	1	--
18	5550038	FTG 45ELB -04 JIC x -04 NPT	1	--
19	5530132	HHB 3/8"-16 x 2-1/4" GR8/CL 10.9	1	--
20	5535998	NUT M10 x 1.5	4	--
21	5585731	AIR HYDRAULIC PUMP YELLOW RJ6W PSI:6100	1	--
22	5215816	RJ6W LOWER ARM ASSEMBLY	2	C

DO NOT SCALE DRAWING

DRAWN: TM 08/25/2015
CHECKED: OK 08/ 9/2022

DIMENSIONS ARE IN MM

THIRD ANGLE PROJECTION

PROPRIETARY AND CONFIDENTIAL
THIS DOCUMENT IS THE PROPERTY OF BENDPAK, INC.
IT IS TO BE USED ONLY FOR THE PROJECT AND FOR WHICH IT IS SPECIFICALLY DESIGNED. IF REWORK IS REQUIRED, CONTACT BENDPAK, INC.

BendPak
1645 ELMWOOD DR.
SANTA PAULA, CA 93060

TITLE: **RJ6W LIFT SUPERSTRUCTURE**

SIZE DWG. NO. **A 5205010** REV **E**

SCALE: 1:10 SHEET 1 OF 2

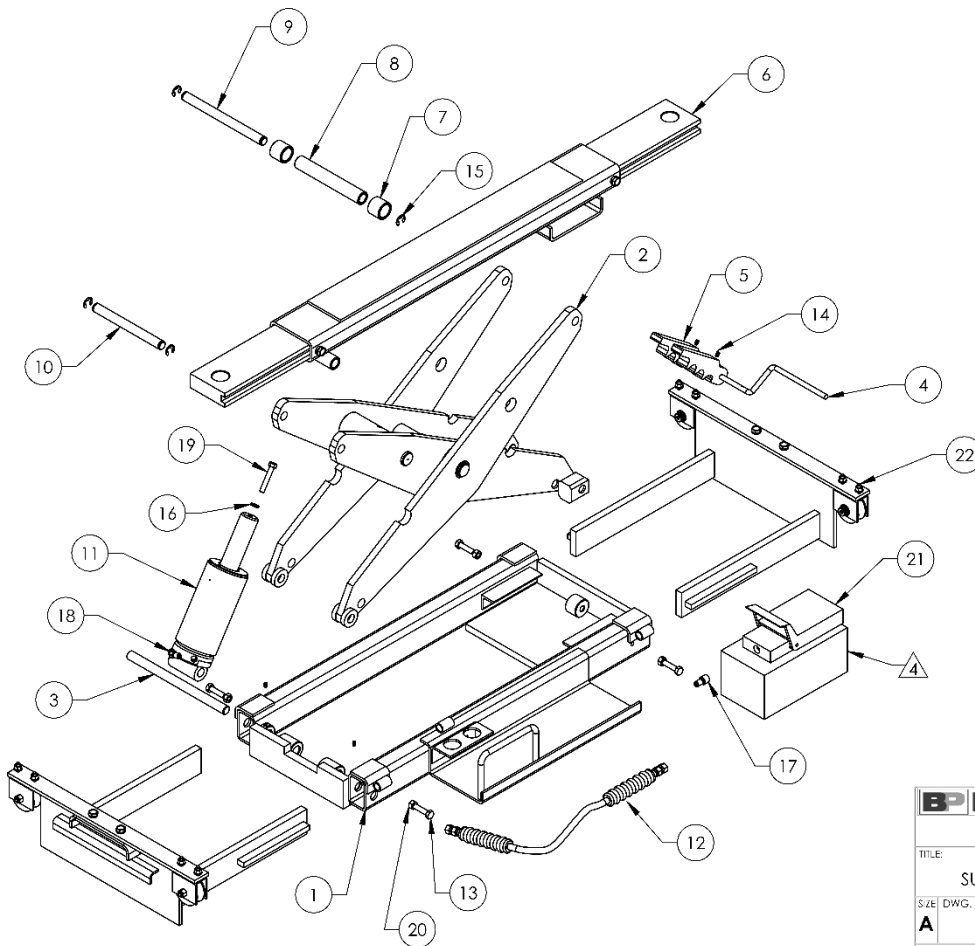

BendPak
 1645 LEMONWOOD DR.
 SANTA PAULA, CA 93060

TITLE: **RJ6W LIFT SUPERSTRUCTURE**

SIZE	DWG. NO.	REV
A	5205010	E

SCALE: 1:10 SHEET 2 OF 2

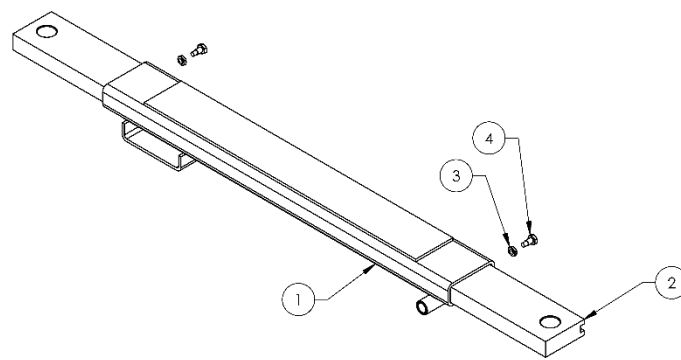

WHERE USED
RJ6W
RJ7W
RJ9W
RBJ7000A

ITEM NO	PART NUMBER	DESCRIPTION	QTY	REV
1	5601029	RJW UPPER ARM RECEIVER TUBE WELDMENT	1	C
2	5735547	RJW EXTENSION ARM BAR	2	C
3	5535035	NUT M10 x 1.5 JN	2	C
4	5530283	HEX BOLT M10 EXTENDED POINT	2	A

DO NOT SCALE DRAWINGS	NAME	DATE	BendPak 1645 LEMONWOOD DR. SANTA PAULA, CA 93060
DIMENSIONS ARE IN MM	DRAWN TM	08/21/2013	
	CHECKED CA	01/09/2019	TITLE: RJW EXTENSION ARM TUBE ASSEMBLY
	THIRD ANGLE PROJECTION		SIZE DWG. NO. REV
			A 5210138 C
<small>PROPRIETARY AND CONFIDENTIAL THIS DRAWING IS THE PROPERTY OF BENDPAK INC. AND IS NOT TO BE REPRODUCED OR TRANSMITTED IN ANY FORM OR BY ANY MEANS, ELECTRONIC OR MECHANICAL, INCLUDING PHOTOCOPYING, RECORDING, OR BY ANY INFORMATION STORAGE AND RETRIEVAL SYSTEM, WITHOUT THE WRITTEN PERMISSION OF BENDPAK INC.</small>			SCALE: 1:8 SHEET 1 OF 1

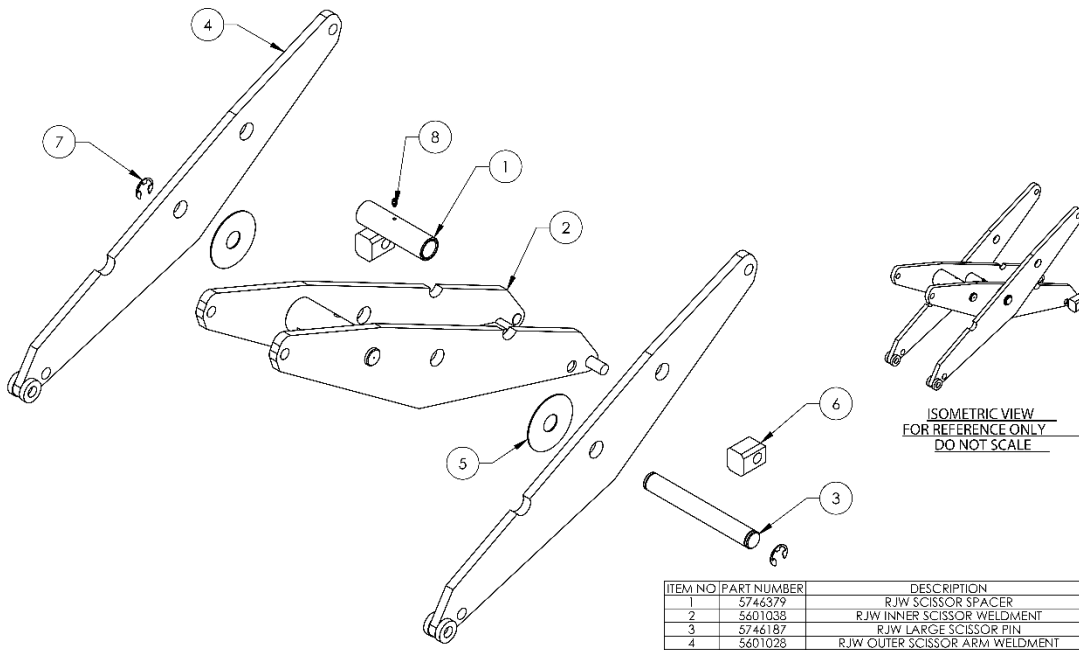

WHERE USED
RJ6W
RJ7W
RJ9W
RB.J7000A

NOTE: UNLESS OTHERWISE SPECIFIED
1. ASSEMBLE ITEMS AS SHOWN

ITEM NO	PART NUMBER	DESCRIPTION	QTY	REV
1	5746379	RJW SCISSOR SPACER	1	B
2	5601038	RJW INNER SCISSOR WELDMENT	1	D
3	5746187	RJW LARGE SCISSOR PIN	1	B
4	5601028	RJW OUTER SCISSOR ARM WELDMENT	2	C
5	5756074	RJW SCISSOR ARM SPACER	2	D
6	5716030	RJW SCISSOR SLIDE BLOCK	2	F
7	5540275	E RING Ø25mm OD DIN 6799 0250	2	-
8	5550025	FTG GRS M6 x 1.0	1	-

DO NOT SCALE DRAWING	NAME	DATE	 1645 LEWISWOOD DR. SANTA PAULA, CA 93060
	DRAWN	TS	
	CHECKED	CA	01/08/2019
DIMENSIONS ARE IN MM	THIRD ANGLE PROJECTION		TITLE
			RJW SCISSOR ASSEMBLY
	SIZE	DWG. NO.	REV
	A	5215439	J
	SCALE: 1:7		SHEET 1 OF 1

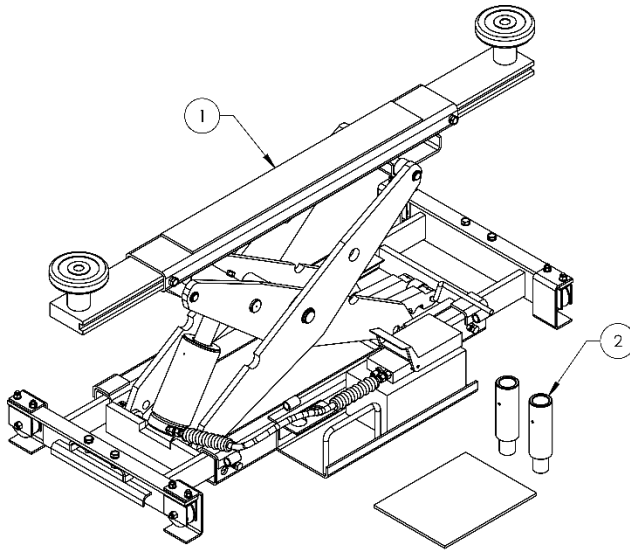

ITEM NO	PART NUMBER	DESCRIPTION	QTY	REV
1	5205011	DJ-6000W, RJ7W LIFT SUPERSTRUCTURE	1	F
2	5250271	DJ-4500/6000W, RJW PARTS BOX	1	F
-	5900093	RJW SERIES MANUAL	1	-

DO NOT SCALE DRAWING	NAME	DATE	 1645 LEWISWOOD DR. SANTA PAULA, CA 93060
	DRAWN	TS	
	CHECKED		
DIMENSIONS ARE IN MM	THIRD ANGLE PROJECTION		TITLE
			RJ7W PRODUCTION LIFT VER F
	SIZE	DWG. NO.	REV
	A	5260284	J
	SCALE: 1:10		SHEET 1 OF 2

WHERE USED
HD-14 SERIES
HDS-14 SERIES
HDSO-14 SERIES

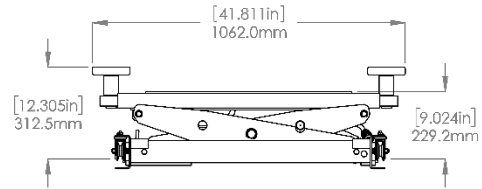
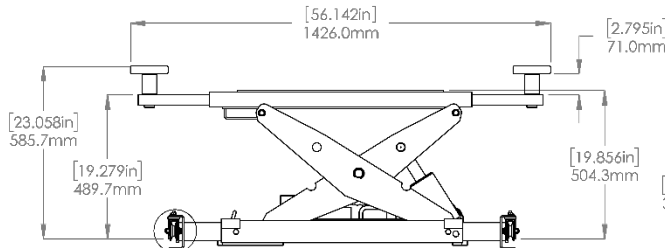
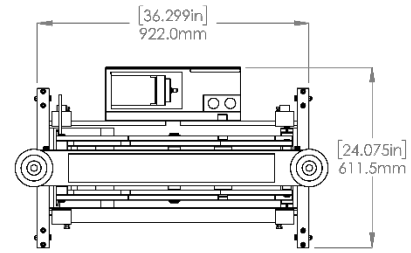
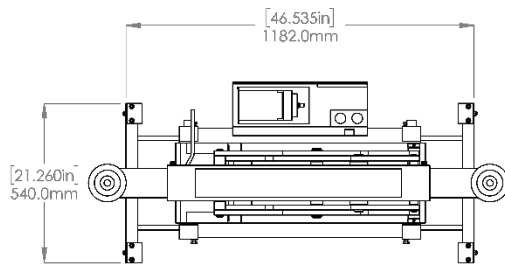

RJW EXTENDED

RJW COLLAPSED

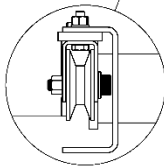

DETAIL A
SCALE 1 : 4

BP BendPak 1645 LEVON WOOD DR. SANTA PAULA, CA 95060		
TITLE: RJW PRODUCTION LIFT VER F		
SIZE: DWG. NO.	REV	
A 5260284	J	
SCALE: 1:15		SHEET 2 OF 2

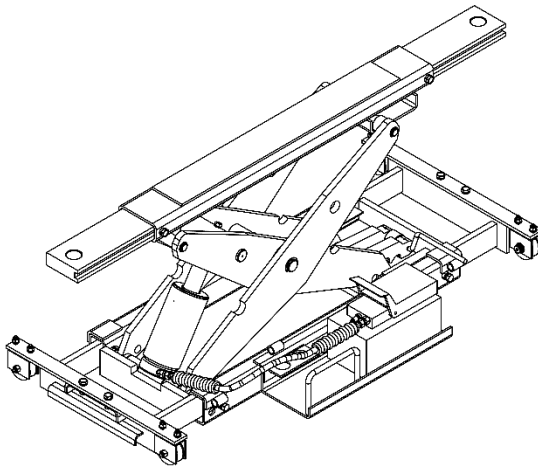

WHERE USED
DJ-6000W
RJW

- NOTE: UNLESS OTHERWISE SPECIFIED**
- REFER TO MODEL FOR ADDITIONAL INFORMATION
 - SEE SHIPPING INSTRUCTIONS FOR FINAL PACKAGING ASSEMBLE ITEMS AS SHOWN
 - AIR HYDRAULIC PUMP MUST BE INSTALLED USING THE INCLUDED BOLTS

ITEM NO	PART NUMBER	DESCRIPTION	QTY	REV
1	5601031	RJW MAIN BODY BASE WELDMENT	1	G
2	5215439	RJW SCISSOR ASSEMBLY	1	J
3	5746374	RJW CYLINDER HINGE ROD	1	D
4	5701136	DJ-6000W, RJ&W/7W/9W SAFETY HANDLE	1	G
5	5731039	RJW SAFETY LATCH	2	H
6	5210138	RJW EXTENSION ARM TUBE ASSEMBLY	1	C
7	5746378	RJW SCISSOR CHANNEL SPACER	2	B
8	5746377	RJW SCISSOR PIN ROLLER TUBE	1	C
9	5746376	RJW SCISSOR PIN	1	B
10	5746375	RJW SHORT SCISSOR PIN	1	B
11	5502012	CYLINDER ASSEMBLY Ø3.0 x 4.375	1	F
12	5570806	RJW SERIES HOSE ASSY Ø6.4mm x 600mm DS	1	E
13	5530302	HHB M10 x 1.5 x 40 FULLY THREAD	4	---
14	5530790	SSS M6 x 1 x 10 NL	4	---
15	5540109	E RING Ø16mm OD DIN 6799 0160	4	---
16	5545130	WASHER 3/8" SL	1	---
17	5550493	FTG RST -04 JIC x -06 NPT x .062 ID	1	---
18	5550038	FTG 45ELB -04 JIC x -04 NPT	1	---
19	5530132	HHB 3/8"-16 x 2-1/4" GR8/CL 10.9	1	---
20	5535998	NUT M10 x 1.5	4	---
21	5585733	AIR HYDRAULIC PUMP YELLOW RJW7 PSI:7500	1	---
22	5215697	RJW BASE ARM SPRING ROLLER PLATE ASSEMBLY	2	E

DO NOT SCALE DRAWING	NAME	DATE	BP BendPak 1645 LEVON WOOD DR. SANTA PAULA, CA 95060
DRAWN	IS	2/05/2018	
CHECKED	OR	06/19/2022	
EM'ING ART: N/AM	THIRD ANGLE PROJECTION		TITLE: DJ-6000W, RJW LIFT SUPERSTRUCTURE
			SIZE: DWG. NO.
<small>PROPRIETARY AND CONFIDENTIAL THE INFORMATION CONTAINED HEREIN IS THE PROPERTY OF BENDPAK INC. © 2018 IT IS TO BE KEPT IN STRICTLY CONFIDENTIAL AND NOT TO BE REPRODUCED OR TRANSMITTED IN ANY FORM OR BY ANY MEANS, ELECTRONIC OR MECHANICAL, INCLUDING PHOTOCOPYING, RECORDING, OR BY ANY INFORMATION STORAGE AND RETRIEVAL SYSTEM.</small>			REV
			F
			SCALE: 1:10
			SHEET 1 OF 2

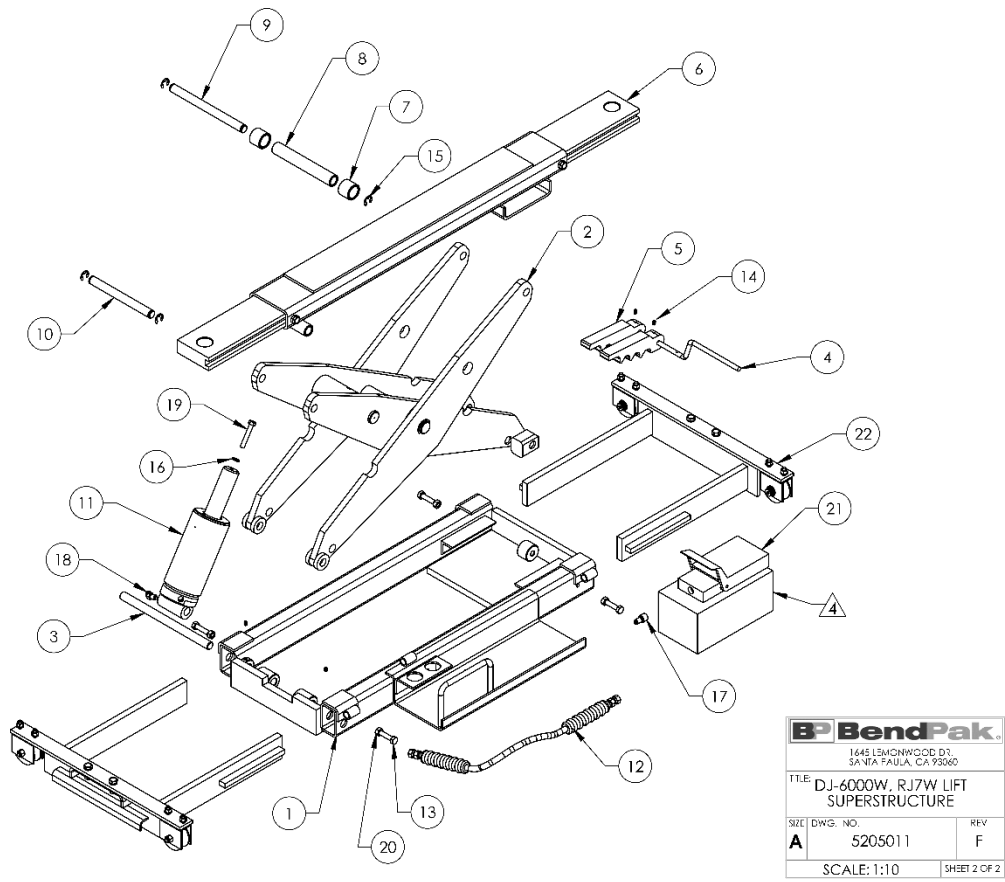

BendPak
 1645 LEMONWOOD DR.
 SANTA PAULA, CA 93060

TITLE: DJ-6000W RJ7W LIFT SUPERSTRUCTURE

SIZE	DWG. NO.	REV
A	5205011	F

SCALE: 1:10 SHEET 2 OF 2

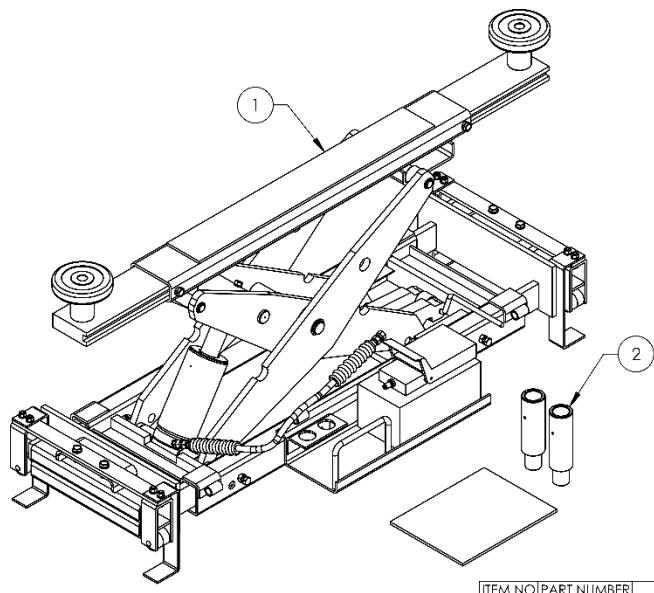

ITEM NO	PART NUMBER	DESCRIPTION	QTY	REV
1	5205012	RJ9W LIFT SUPERSTRUCTURE	1	D
2	5250273	RJ9W PARTS BOX	1	D
-	5900093	RJW SERIES MANUAL	1	--

DO NOT SCALE DRAWING	NAME:	DATE
	DRAWN: TS	12/14/2018
	CHECKED:	
THIRD-ANGLE PROJECTION		
WHERE USED	BendPak 1645 LEMONWOOD DR. SANTA PAULA, CA 93060	
HDS-18 SERIES	TITLE: RJ9W PRODUCTION LIFT VER D SIZE: DWG. NO. A 5260286 REV J SCALE: 1:10 SHEET 1 OF 2	

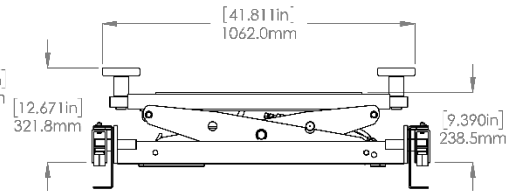
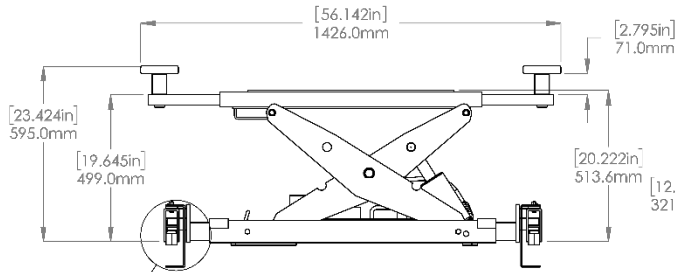
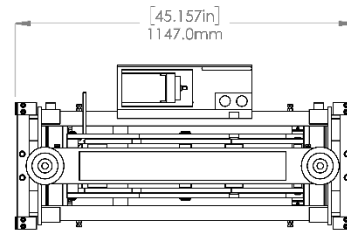
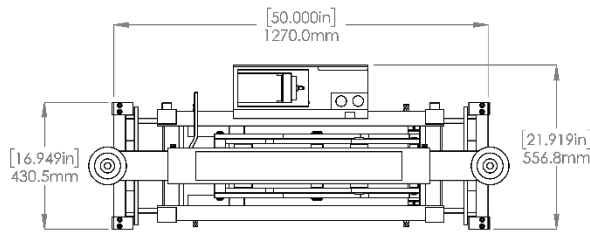

RJ9W EXTENDED

RJ9W COLLAPSED

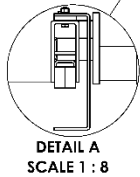

BendPak 1645 LEMONWOOD DR. SANTA PAULA, CA 93060	
TITLE: RJ9W PRODUCTION LIFT VER D	
SIZE: DWG. NO. A	REV J
SCALE: 1:15 SHEET 2 OF 2	

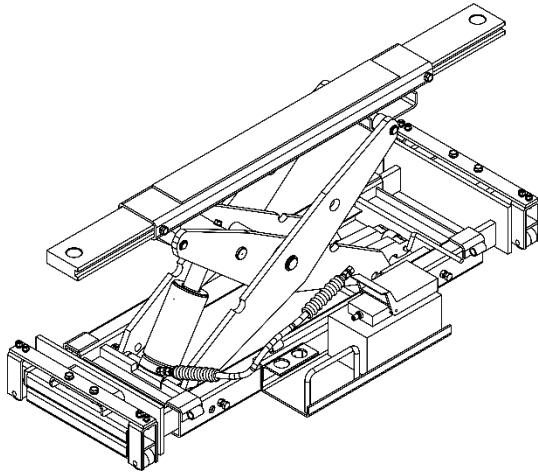

WHERE USED
RJ9W

NOTE: UNLESS OTHERWISE SPECIFIED

- REFER TO MODEL FOR ADDITIONAL INFORMATION
- SEE SHIPPING INSTRUCTIONS FOR FINAL PACKAGING ASSEMBLY ITEMS AS SHOWN
- AIR HYDRAULIC PUMP MUST BE INSTALLED USING THE INCLUDED BOLTS

ITEM NO	PART NUMBER	DESCRIPTION	QTY	REV
1	5601039	RJ9W BASE WELDMENT	1	G
2	5215439	RJW SCISSOR ASSEMBLY	1	J
3	5502012	CYLINDER ASSEMBLY Ø3.0 x 4.375	1	F
4	5210138	RJW EXTENSION ARM TUBE ASSEMBLY	1	C
5	5570806	RJW SERIES HOSE ASSY Ø6.4mm x 600mm DS	1	E
6	5746374	RJW CYLINDER HINGE ROD	1	D
7	5746375	RJW SHORT SCISSOR PIN	1	B
8	5746376	RJW SCISSOR PIN	1	B
9	5746377	RJW SCISSOR PIN ROLLER TUBE	1	C
10	5746378	RJW SCISSOR CHANNEL SPACER	2	B
11	5731039	RJW SAFETY LATCH	2	H
12	5701136	DJ-6000W, RJ6W/7W/9W SAFETY HANDLE	1	G
13	5530132	HHB 3/8"-16 x 2-1/4" GR8/CL 10.9	1	-
14	5545130	WASHER 3/8" SL	1	-
15	5530302	HHB M10 x 1.5 x 40 FULLY THREAD	4	-
16	5535998	NUT M10 x 1.5	4	-
17	5550038	FTG 45ELB-04 JIC x -04 NPT	1	-
18	5585734	AIR HYDRAULIC PUMP YELLOW RJ9W PSI:7000	1	-
19	5540109	E RING Ø16mm OD DIN 6799 0160	4	-
20	5530790	SSS M6 x 1 x 10 NL	4	-
21	5550493	FTG RST-04 JIC x -06 NPT x .062 ID	1	-
22	5210197	RJ9W ARM EXTENSION ASSEMBLY	2	B

30 INCH SCALE DRAWING	NAME: DATE	BendPak 1645 LEMONWOOD DR. SANTA PAULA, CA 93060
DRAWN: TS 12/11/2018	CHECKED: CW 08/19/2022	TITLE: RJ9W LIFT SUPERSTRUCTURE
DESIGNER: BAW	THIRD ANGLE PROJECTION	SIZE: DWG. NO. A
		REV D
<small>FOR INFORMATION AND COMMENTARY ONLY. THIS DRAWING IS NOT TO BE USED FOR CONSTRUCTION WITHOUT THE WRITTEN PERMISSION OF BENDPAK INC.</small>	SCALE: 1:10	SHEET 1 OF 2

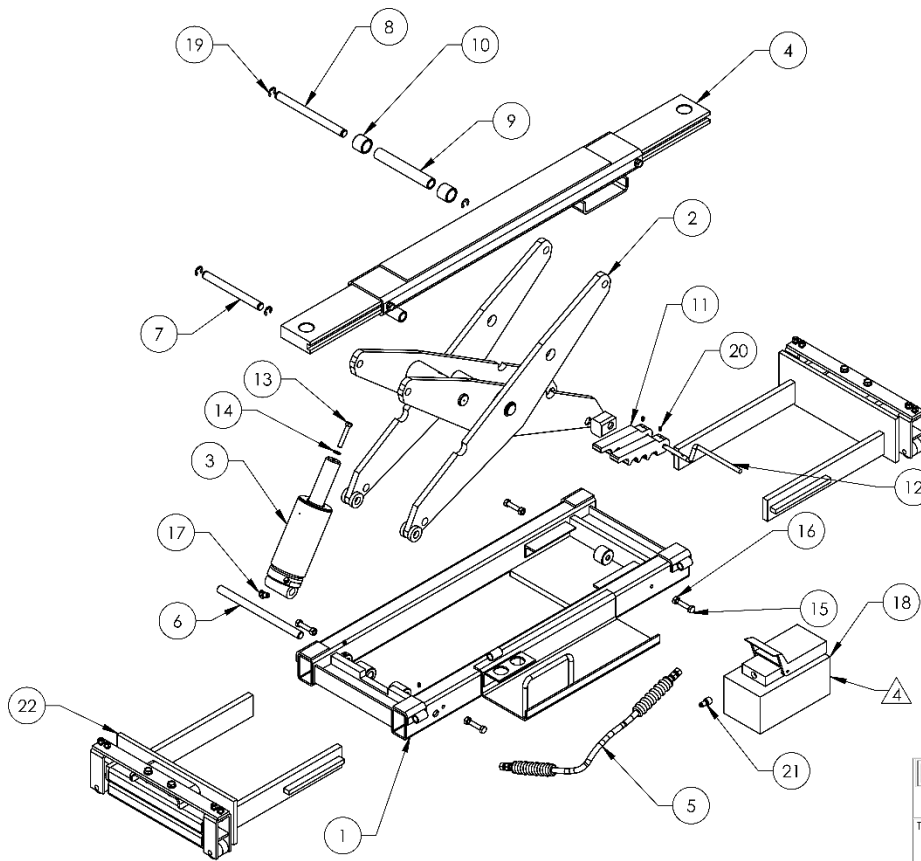

BendPak
 1645 LEMONWOOD DR.
 SANTA PAULA, CA 93060

TITLE: **RJ9W LIFT SUPERSTRUCTURE**

SIZE	DWG. NO.	REV
A	5205012	D

SCALE: 1:12 SHEET 2 OF 2

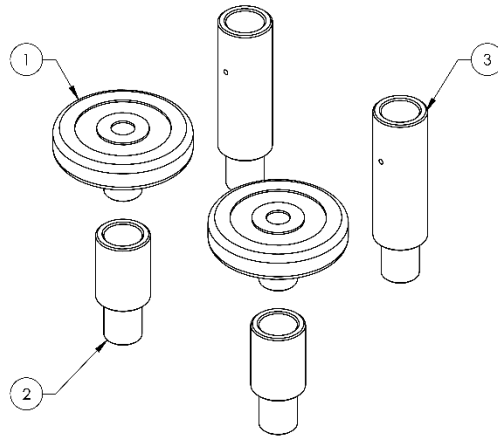
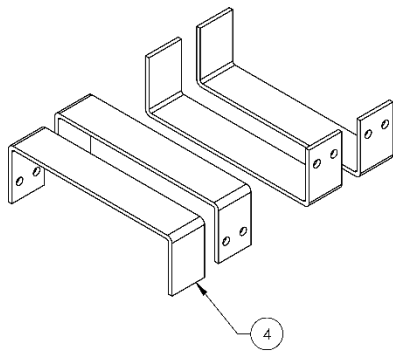

WHERE USED
RJ9W

ITEM NO.	PART NUMBER	DESCRIPTION	QTY.	REV
1	5215507	ROUND LIFT PAD ADAPTER ASSEMBLY	2	G
2	5746390	MEDIUM LIFT PAD EXTENSION Ø35 x 113mm	2	E
3	5746395	LONG LIFT PAD EXTENSION Ø35 x 182mm	2	D
4	5701555	RJ9W SPRING PLATE SAFETY BRACKET	4	B

DESIGNED BY: TS	DATE: 11/16/2017	BendPak 1645 LEMONWOOD DR. SANTA PAULA, CA 93060
DRAWN BY: TS	DATE: 11/16/2017	
CHECKED BY: CR	DATE: 01/02/2020	TITLE: RJ9W PARTS BOX
THIRD ANGLE PROJECTION		SIZE: DWG. NO. A 5250273 REV D
		SCALE: 1:4 SHEET 1 OF 1

PROPRIETARY AND CONFIDENTIAL
 THIS INFORMATION IS TO BE KEPT CONFIDENTIAL
 THE PROPERTY OF BENDPAK INC. ALL
 INFORMATION CONTAINED HEREIN IS THE PROPERTY OF
 BENDPAK INC. AND IS NOT TO BE REPRODUCED OR
 TRANSMITTED IN ANY FORM OR BY ANY MEANS
 WITHOUT THE WRITTEN PERMISSION OF BENDPAK INC.

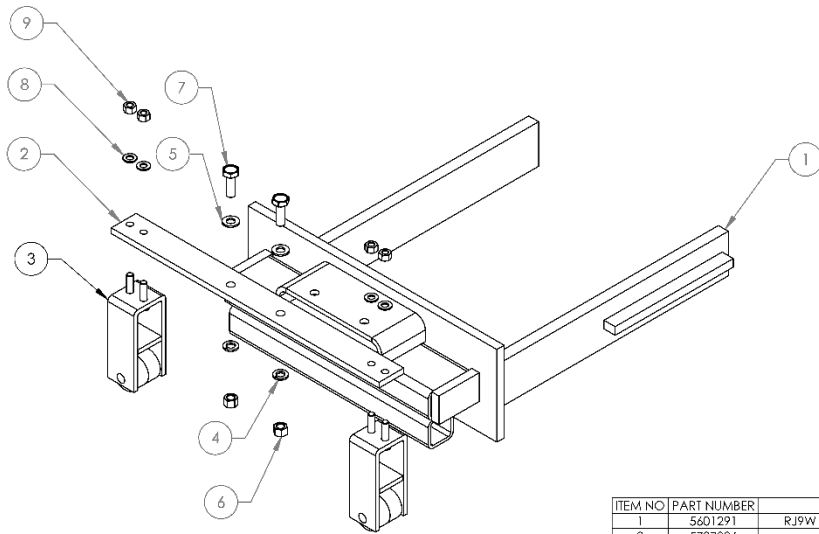

WHERE USED
RJ9W

ITEM NO	PART NUMBER	DESCRIPTION	QTY	REV
1	5601291	RJ9W BASE EXTENSION ARM WELDMENT	1	A
2	5737086	RJ9W SPRING PLATE	1	B
3	5601292	RJ9W ROLLER BRACKET ASSEMBLY WELDMENT	2	B
4	5545023	WASHER M10 SL	2	--
5	5545341	WASHER M10 x Ø20 FLAT	2	--
6	5535013	NUT M10 x 1.5 NL	2	--
7	5530021	HHB, M10 x 1.5 x 30	2	--
8	5545012	WASHER, M8x1.6x1.6mm FLAT	4	--
9	5535001	NUT M8 x 1.25 NL	4	--

JOB NO: SCALE: DRAWING		NAME	DATE	 1445 LENOX WOOD DR. SANTA PAULA, CA 93080
DRAWN	TS	12/13/2018		
CHECKED	CA	05/02/2017		
DIMENSIONS ARE IN: MM		THIRD ANGLE PROJECTION		TITLE: RJ9W ARM EXTENSION ASSEMBLY SIZE: DWG. NO. 5210197 SCALE: 1:5
				REV: B SHEET 1 OF 1
<small> PROPRIETARY AND CONFIDENTIAL THIS INFORMATION IS UNCLASSIFIED AND IS NOT TO BE RELEASED TO THE PUBLIC WITHOUT THE WRITTEN PERMISSION OF BENDPAK, INC. </small>				

Automotive Lift Institute (ALI) Store

You probably checked the [ALI's Directory of Certified Lifts](http://www.autolift.org/ali-directory-of-certified-lifts/) (www.autolift.org/ali-directory-of-certified-lifts/) before making your most recent Lift purchase, but did you know the **ALI Store** (www.autolift.org/ali-store/) offers a wide variety of professional, easy-to-use, and reasonably priced training and safety materials that will make your garage a safer place to work?

The ALI Store is your trusted source for workplace safety!



Lifting It Right Online Certificate Course. Make *sure* you and your people are lifting vehicles the right way.



ALI Lift Inspector Certification Program Registration. Become a ALI Certified Lift Inspector.

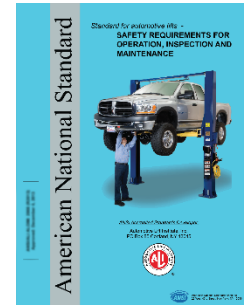

ANSI/ALI ALOIM Standard for Automotive Lifts. Safety Requirements for Operation, Inspection, and Maintenance.

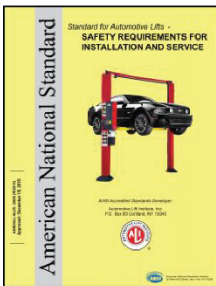

ANSI/ALI ALIS Standard. Safety Requirements for Installation and Service.

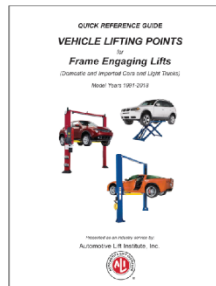

Guide to Identifying Vehicle Lifting Points for Frame-Engaging Lifts. Don't eyeball your lifting points, *know* where they are.



Lift Operator Safety Materials. Five safety documents in a single package.

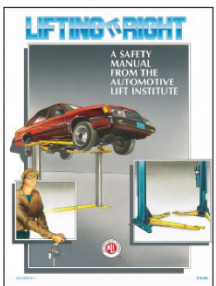

Lifting It Right. A hardcopy version of the *Lifting It Right* safety manual from the Automotive Lift Institute.

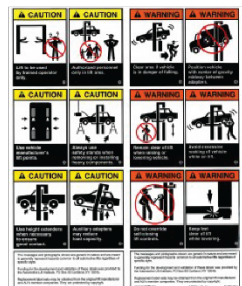

Uniform Warning Labels and Placards for 2-Posts. Labels in Mandarin, French Canadian, and Spanish are also available.



Safety Tips Card. Reminds your people of 13 key safety tips to follow daily.

Visit today and get the training and materials you need to work safely:
www.autolift.org/ali-store/.

BendPak[®]

30440 Agoura Road
Agoura Hills, CA, 91301 USA