

# XPR-12FDL



## Two-Post Lifts

SKU# 5175403

12K Capacity, Floorplate, Direct-Drive, Triple-Telescoping Arms

Questions? Contact BendPak's Sales Team

sales@bendpak.com | 1-800-253-2363

Monday - Friday, 7AM to 4:30PM PST

## XPR-12FDL Offers Heavy-Duty Lifting Capability

The XPR-12FDL [two-post lift](#) is the perfect lifting application for everything that falls in its weight class. Two robust posts are capable of raising some truly massive trucks and SUVs. This might be classified as our "medium-duty" lift, as it covers almost every vehicle in the homeowner/residential arena. It also lifts some commercial vans and trucks, including high-rise vehicles. The XPR-12FDL is an open-top design. An open-top car lift does not have a crossbar over the top of the lift, which is desirable for taller vehicles. The hydraulic lines run on the floor, under a floorplate, between the posts.



## Features

- CE Approved and Certified. Meets or exceeds the standards prescribed by European Standard EN 1493
- Open-top eliminates overhead obstruction
- Single-piece columns
- Single-point safety release
- Drop-end arms provide a lower pad height
- Dual direct-drive hydraulic cylinders
- Oversized 53" tall carriage for superior strength
- Large, 25" x 22" A36 steel base plate
- Electric / hydraulic power system
- Oversized A36 steel base plates
- Self-lubricating dura-glide UHMW polyethylene bearings
- Safety locks in each column spaced every 3"
- Automatic arm restraints
- Heavy-duty 1/2" aircraft-quality equalizer cables
- Oversized 6" cable sheave diameter reduces cable fatigue
- 16-piece specialty adapter set includes four 6" stackable adapters, four 3" stackable adapters, four polyurethane contact pads and four frame cradle pads
- Front and rear triple-telescoping arms provide increased range for lifting point access
- Versatile drop-in contact pads with stackable adapters

If you appreciate the superior quality of a BendPak XPR-9 or 10 series two-post lift but need more lifting power, the XPR-12FDL is an open-top car lift that's packed with pure, brutish muscle. This lift is perfect for shops and garages with ceilings 14' and higher.

### Dual Direct-Drive two-post car lift technology

We prefer Direct-Drive technology for our 12K car lift, as opposed to lifting chains and screw mechanisms. Direct-Drive hydraulic technology has very few moving parts, so there's less that can go wrong or require service over time. We carefully engineering the dual-synchro equalization system to ensure safe, level working conditions at all times.

### Triple-telescoping arm set

Our lighter-duty two-post lift models feature a mixture of two-stage and three-stage telescoping arms. Because a 12K capacity lift needs to make room for wide trucks, vans and SUVs, we set the columns farther apart. We can still reach virtually all lift points on smaller vehicles by including three-stage arms.

### Low-profile, dropped-end frame contact pads

The XPR-12FDL makes safely reaching under low-profile cars safe and easy. The dropped-end design ensures vehicle doors and chassis don't get scratched or dinged during placement of the arms and pads against the lift points.

# Specifications



Model	XPR-9S	XPR-9DS	XPR-12FDL
<b>Style</b>	Chain-Over / Adjustable Width	Direct-Drive / Adjustable Width	Direct-Drive
<b>SKU#</b>	5175390	5175393	5175403
<b>Lifting Capacity</b>	9,000 lbs. (4,082 kg)	9,000 lbs. (4,082 kg)	12,000 lbs. (5,443 kg)
<b>A - Rise</b>	72" (1,829 mm)	69" (1,753 mm)	69" (1,753 mm)
<b>B - Rise + Pad Only</b>	78" (1,981 mm)	75" (1,905 mm)	74" (1,880 mm)
<b>C - Max. Lifting Height</b>	80.5" (2,044 mm)	77.5" (1,968 mm)	79" (2,007 mm)
<b>D - Min. Height + Pad</b>	4.25" (108 mm)	4.25" (108 mm)	5" (127 mm)
<b>E - Height Overall</b>	113" (2,870 mm)	145" (3,683 mm)	144" (3,403 mm)
<b>F - Width Overall</b>	132" (3,353 mm) - 145" (3,683 mm)	132" (3,353 mm) - 145" (3,683 mm)	155" (3,937 mm)
<b>G - Outside Columns</b>	126.75" (3,225 mm) - 139.75" (3,555 mm)	126.75" (3,225 mm) - 139.75" (3,555 mm)	146" (3,708 mm)
<b>H - Inside Columns</b>	105" (2,667 mm) - 118" (2,997 mm)	105" (2,667 mm) - 118" (2,997 mm)	118" (2,997 mm)
<b>I - Drive-Thru Clearance</b>	93" (2,362 mm) - 106" (2,692 mm)	93" (2,362 mm) - 106" (2,692 mm)	103" (2,616 mm)
<b>J - Front Arm Reach (MIN)</b>	28.5" (724 mm)	27.5" (698 mm)	39" (991 mm)
<b>J - Front Arm Reach (MAX)</b>	47.5" (1,206 mm)	51.5" (1,308 mm)	59" (1,499 mm)
<b>K - Rear Arm Reach (MIN)</b>	28.5" (24 mm)	34" (863 mm)	39" (991 mm)
<b>K - Rear Arm Reach (MAX)</b>	47.5" (1,206 mm)	54.5" (1,384 mm)	59" (1,499 mm)
<b>Screw Pad Adjustment</b>	1.75" (44.5 mm)	1.75" (44.5 mm)	N/A
<b>Max. Load per Arm</b>	2,250 lbs. (1,021 kg)	2,250 lbs. (1,021 kg)	3,000 lbs. (1,361 kg)
<b>L - Floorplate Height</b>	1.75" (44 mm)	1.75" (44 mm)	2" (51 mm)
<b>M - Floorplate Width</b>	8.5" (216 mm)	8.5" (216 mm)	8.5" (216 mm)
<b>Time to Full Rise</b>	45 seconds	45 seconds	55 seconds
<b>Noise</b>	90 dB	90 dB	90 dB
<b>Motor</b>	220 VAC / 60 Hz / 1 Ph	220 VAC / 60 Hz / 1 Ph	220 VAC / 60 Hz / 1 Ph

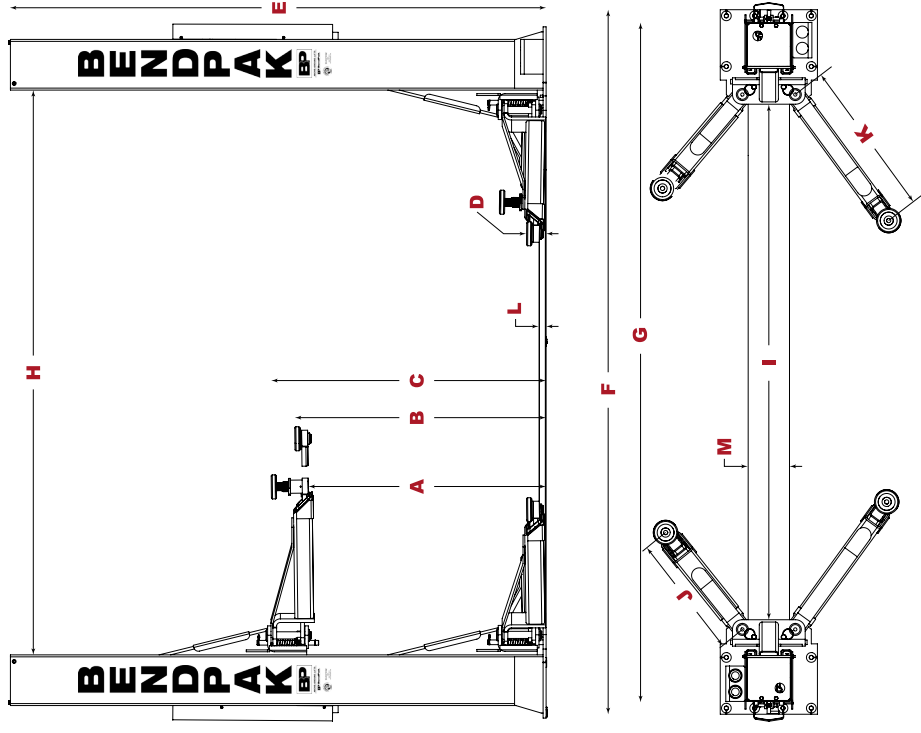

Not all BendPak lift models meet the standards as prescribed by ANSI/ALI ALCTV-2017 or ANSI/JUL 201. Consult [www.autolift.org](http://www.autolift.org) for a complete list or contact BendPak via [contact@bendpak.com](mailto:contact@bendpak.com).