

F10P

Stratus 10,000 LBS Capacity
Two Post Floor Plate Lift



WWW.STRATUSAUTOEQUIP.COM

STRATUS
auto equipment[®]

512-640-9896
8413 Calibration Ct
College Station, TX 77845
sales@stratusautoequip.com

TECHNICAL

Model	F10P
Capacity	10,000LBS
Overall Height - A	111 1/4" (2826 MM)
Overall Width - B	19 11/16" (500 MM)
Overall Length - C	134 1/4" (3410 MM)
Max Lifting Height with Adaptors - D	81 7/8" (2080 MM)
Min Lifting Height with Adaptors - E	5 1/8" (130 MM)
Max Lifting without Adaptors - F	76 3/4" (1950 MM)
Min Lifting without Adaptors - G	3 3/4" (95 MM)
Lifting Time	~50SEC
Width between columns - H	112 3/16" (2850 MM)
Drive Clearance - I	101 5/16" (2574 MM)
Front Arm Reach Max - J	56 15/16" (1440 MM)
Front Arm Reach Min - K	34 5/8" (880 MM)
Rear Arm Reach Max - L	48 7/16" (1230 MM)
Rear Arm Reach Min - M	26 3/4" (680 MM)
Motor	3 HP, 220V, 60 HZ, 1PH
Oil	AW32 or AW46
Breaker	30A
Weight	1,385 LBS
Dimension	116" L * 25" W * 35" H
Concrete Requirement	6" – 3000 PSI

DIMENSIONS

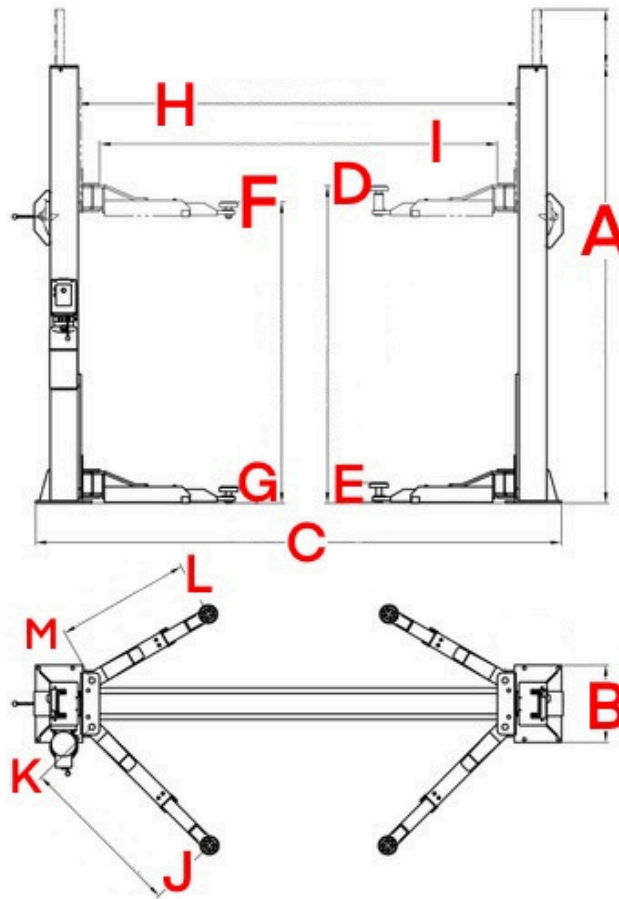

FEATURES

- Base plate / Open top
- Single point manual release
- Top limiter switch
- CE certified
- Proofed by dynamic test with 115% of rated capacity and static test with 150% rated capacity
- Powder coating finish: Granite Gray (RAL 7026) + Reinorange (RAL 2004)

Standard Accessories (Included)

- 4pcs- Screw-Up Rubber Pads
- 8pcs- Truck Adapters sizes include 4pcs-2 3/4" & 4pcs-4" 2 of 2-Stage
- Arms 2 of 3-Stage Arms
-

View it on the website here:

