

Safety - Installation - Operation - Maintenance

## Extra Wide Commercial Grade Open Center Mobile Mid Rise Electric Safety Lock Release Scissor Vehicle Lift

Models: MS9000X / MS9000XT



SHOWN: MS9000X

Manual MS9000XT – Revision A1 – Jan2023

### IMPORTANT NOTE:

1. Save these instructions!
2. This equipment should not be installed, operated or repaired without first reading instructions. Failure to follow the instructions and safety guidelines can result in serious injury or death.
3. Electricity should be hooked up by a certified electrician.
4. Do NOT use equipment beyond its rated capacity.
5. Keep manual near lift for reference
6. By proceeding with installation and operation, you agree that you fully understand the contents of this manual and assume full responsibility for product use.
7. Only Operate this lift if it can be done so safely.

**Manual** - MS9000XT- Extra Wide Commercial Grade Open Center Mobile Mid Rise Electric Safety Lock Release Scissor Vehicle Lift - Safety - Installation - Operation - Maintenance -MSSERIES–  
Revision A1 – July 2023

**Copyright** - Copyright © 2023 by Stratus Metals, Inc. dba Stratus Auto Equipment reserves all rights. Copies may be made of this document if you agree full attribution to Stratus Metals Inc. Changes and Copies for commercial purposes to this document are prohibited.

**Trademarks**- Stratus Auto Equipment and logo are registered trademarks of Stratus Metals, Inc. All other company, product, and service names are used for identification only. All trademarks and registered trademarks mentioned in this manual are the property of their respective owners.

**Limitations**- Whereas every effort has been made to ensure this manual has complete and accurate information; Product updates, revisions, and/or changes could have occurred since this manual was written and published. Stratus Auto Equipment reserves the right to change any information in this manual without incurring any obligation for equipment previously or subsequently sold. Stratus Auto Equipment is not responsible for typographical errors in this manual.

**Safety**- Your product was designed and manufactured with safety in mind. However, your safety also depends on proper training and thoughtful operation. Do not install, operate, maintain, or repair the unit without reading and understanding this manual and the labels on the unit; *do not use your Lift unless you can do so safely!*

**Owner Responsibility**- In order to ensure operator safety and maintain your product properly, it is the responsibility of the product owner to read and follow these instructions:

- Follow all setup, operation, and maintenance instructions.
- Make sure product setup and use conforms to all applicable local, state, and federal codes, rules, and regulations, such as state and federal OSHA regulations and electrical codes.
- Read and follow all safety instructions. Keep them readily available for operators.
- Make sure all operators are properly trained, know how to safely operate the unit, and are properly supervised.
- Do not operate the product until you are certain all parts are in place and operating correctly.
- Carefully inspect the product on a regular basis and perform all maintenance as specified.
- Service and maintain the unit only with approved replacement parts.
- Keep all instructions permanently with the product and make sure all labels are clean and visible.

Stratus Auto Equipment makes no promises, guarantees or assurances that our products meet any state, county, federal or international mandated permit, license, code, standard, certification, or any other mandate other than what is listed or shown on Stratus Auto Equipment's website. Not all of Stratus Auto Equipment lift models meet the standards as prescribed by ANSI/ALI ALCTV-(current edition) or ANSI/UL 201. Consult [www.autolift.org](http://www.autolift.org) for a complete list of lift models that meet ANSI/ALI ALCTV-(current edition) or ANSI/UL 201 or contact support@stratusautoequip.com

Buyer assumes full responsibility for any state, county, federal or international mandated permit, license, code, standard, certification, or any other mandate required related to the installation and/or operation of any Stratus Equipment. Stratus will not be responsible for any charges, fines, liens, or other levies imposed on the Buyer related to any special or regional structural, seismic or any other building code and/or codes such as the Uniform Building Code (UBC), International Building Code (IBC), or any other state, county, federal or international mandated permit, license, code, standard, certification, or other mandate, law, rule, regulation or directive by any other agency, government, administrations, or corporations whether state, county, federal, or international mandated.

## Unit Information

Be sure to document the Model Number, Serial Number, and Date of Manufacture from the label on your unit. This information is required for part or warranty issues.



**STRATUS**<sup>®</sup>  
auto equipment

STRATUS AUTO EQUIPMENT  
www.stratusautoequip.com  
sales@stratusautoequip.com  
Tel: 512-640-9896



MODEL:

DATE:

SERIAL NO.

Lifting Capacity:

 lbs

Rated Voltage:

 V

Lifting Height:

 in

Rated Frequency:

 Hz

Min Height:

 in

Phase:

 Ph

Platform Length:

 in

Net Weight:

 lbs

## Contents

Chapter 1	Introduction	4	Chapter 11	Features	15
Chapter 2	Symbols	5	Chapter 12	Components	16
Chapter 3	Liability	5	Chapter 13	Electrical	18
Chapter 4	Safety Instruction	6	Chapter 14	Checklist	19
Chapter 5	Labels	9	Chapter 15	Preparation	20
Chapter 6	FAQ	11	Chapter 16	Installation	22
Chapter 7	Warranty	14	Chapter 17	Operation	32
Chapter 8	Shipping	14	Chapter 18	Troubleshooting	36
Chapter 9	Returns	14	Chapter 19	ALI	37
Chapter 10	Parameters	15	Chapter 20	Exploded View	38

## Introduction

This manual is designed to help customers use Stratus MS series scissor lifts. These are mid rise, with an open center that provides full under vehicle access. These lifts can be installed at ground level or flush mounted (in ground).

These lifts come with a capacity of 9000 Lbs.

Stratus does recommend keeping this manual within reach of the lift for anyone who is to use or service the machine. Frequently asked questions and Troubleshooting have been included within this manual. If you question and/or issue which is not answered here, please contact us at 512-640-9896 or email [support@stratusautoequip.com](mailto:support@stratusautoequip.com)

## Symbols

Following are the symbols used in this manual:

 **DANGER** Calls attention to an immediate hazard that will result in injury or death.

 **WARNING** Calls attention to a hazard or unsafe practice that could result in injury or death.

 **CAUTION** Calls attention to a hazard or unsafe practice that could result in minor personal injury, product, or property damage.

**NOTICE** Calls attention to a situation that, if not avoided, could result in product or property damage.



**Tip**

Calls attention to information that can help you use your product better.

## Liability

Stratus Auto Equipment assumes no liability for damages resulting from:

- Use of the product for purposes other than those described in this manual.
- Modifications to the equipment without prior, written permission from Stratus
- Injury or death caused by modifying, disabling, overriding, or removing safety features.
- Damage to the equipment from external influences.
- Incorrect operation of the equipment.

## Safety Instructions

- Make sure that you have read the User's Manual completely including relevant instructions on installation, operation and safety before operating the lift.
- This lift is designed for lifting vehicles. Any other use may result in damage of the lift or injury to personnel.
- Only those who have been properly trained should operate the lift. The vehicle customer or inexperienced persons are prohibited from operating the lift at will. Keep children and untrained personnel away from the Lift.
- Do not overload the lift beyond its rated capacity. To reduce the risk of injury, never attempt to lift more than the rated capacity. Refer to loading instructions. The lift is designed to lift the entire body of vehicles with weight within the lifting capacity.
- If lift designed for indoor use only. Outdoor use is prohibited
- Do not install lift on any surface other than concrete that is at least 6" thick and has set for at least 30 days.
- Do not move away from controls while lift is in motion.
- Keep hands and feet away from any moving parts, Do not put hands at any dangerous place, such as the space between tool arms.
- Do not wear any loose clothing that could be caught in moving parts. Keep hair, fingers, and all parts of body away from moving parts. Always wear appropriate safety equipment during operation.
- Keep area around lift clean to avoid incidents. Any oil stain or obstacle may pose a safety risk.
- Always ensure the safety latches are operational before any attempt to work near or under the vehicle. Be sure to perform mechanical locking after the vehicle is lifted. It is prohibited to work under the vehicle before mechanical locking is performed.
- Ensure regular maintenance is completed. If anything, abnormal occurs, stop using lift and immediately contact us for help. Do not use the lift if any abnormality is found.
- Do not rock vehicle while on lift or remove heavy components that may cause weight shift as vehicle could fall.

- Do not modify any part of the lift without manufacturers advice. Do not make any modifications to the Lift; this voids the warranty and increases the chances of injury or property damage.
- If lift is not in use, lower to the lowest position and disconnect power. Be sure to cut off the power supply after the use of lift.
- It is prohibited to lift the vehicle when someone is in the vehicle.
- When a vehicle is being loaded onto or unloaded from the lift, no person is allowed to stand in the vehicle passage.
- Do not use the Lift while tired or under the influence of drugs, alcohol, or medication.
- Keep areas well lit.
- Keep loads balanced on the Lift Platforms. Clear the area immediately if a Vehicle is in danger of falling off the Lift. **DO NOT ATTEMPT TO CATCH!**
- The rubber pad of the small scissor lift must have contact with the support point of the vehicle, otherwise the vehicle chassis may be damaged. (It is recommended to consult the vehicle manufacturer by telephone if the location of the support point is not clear.)
- Make sure there is no obstacle under the vehicle before lowering it
- If the lift will be left unused for a long period of time, it is recommended that the user disconnects power, empty the oil tank, and lubricate any moving parts with hydraulic oil.

**Attention: For environment protection, please dispose the disused oil in a proper way.**

## **WARNING:**

1. The warning, cautions and instructions discussed in this manual cannot cover all possible conditions and situations that may occur. It must be understood by the operator that common sense and caution are factors which cannot be built into this product, but must be supplied by operator.
2. **ALWAYS** ensure the mechanical safety locks are engaged. Never remove safety related components from the lift. Do not use if safety related components are damaged or missing.
3. Failure to correctly install, operate, or any improper modifications could result in injury or death of operators.



## Safety Signs

All safety warning labels are clearly depicted on the lift to ensure that the operator is aware of and avoids the dangers of using the lift in an incorrect manner. The labels must be kept clean and they have to be replaced if detached or damaged. Please read carefully the meaning of each label and memorize them for future operation.

**Caution**



Never stand, work or be under the lift while it is being operated

**Caution**



Operator should not stand too close to lift but in a safe position away from moving parts

**Caution**



Never try to lift or lower only 1 platform

**Caution**



Ensure feet and other body parts are clear of lift when lifting or lowering

**Warning**



Do not shake or push vehicle while it is on the lift

**Warning**



When the lift is lowered, no auxiliary stand or other blocking objects should be near the lift

**Warning**



Only trained technicians are permitted to operate lift

**Warning**



Do not change, tamper or interfere with the safety mechanisms of this lift

**Warning**



Ensure that the lifting weight of the vehicle is balanced on both platforms to avoid tilting or sliding

**Warning**



High voltage in control box, use extreme caution



## Labels

A

<b>STRATUS</b> auto equipment		STRATUS AUTO EQUIPMENT www.stratusautoequip.com sales@stratusautoequip.com Tel: 532-640-9895		CE	
MODEL:	_____	DATE:	_____		
SERIAL NO.	_____				
Lifting Capacity:	_____ lbs	Rated Voltage:	_____ v		
Lifting Height:	_____ in	Rated Frequency:	_____ Hz		
Min Height:	_____ in	Phase:	_____ Ph		
Platform Length:	_____ in	Net Weight:	_____ lbs		

B



- Only trained personnel is allowed to use the lift.
- Read the entire manual before operating
- Never try to raise the vehicle exceeding lift capacity
- Make sure you meet all safety requirements before you start working under the vehicle
- Surrounding of lift will remain clear when raising or lowering
- The manufacturer and distributor will not take any responsibility if user does not follow the operation manual that comes with the lift

C



D

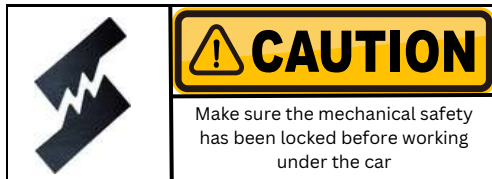

E



# Measurements

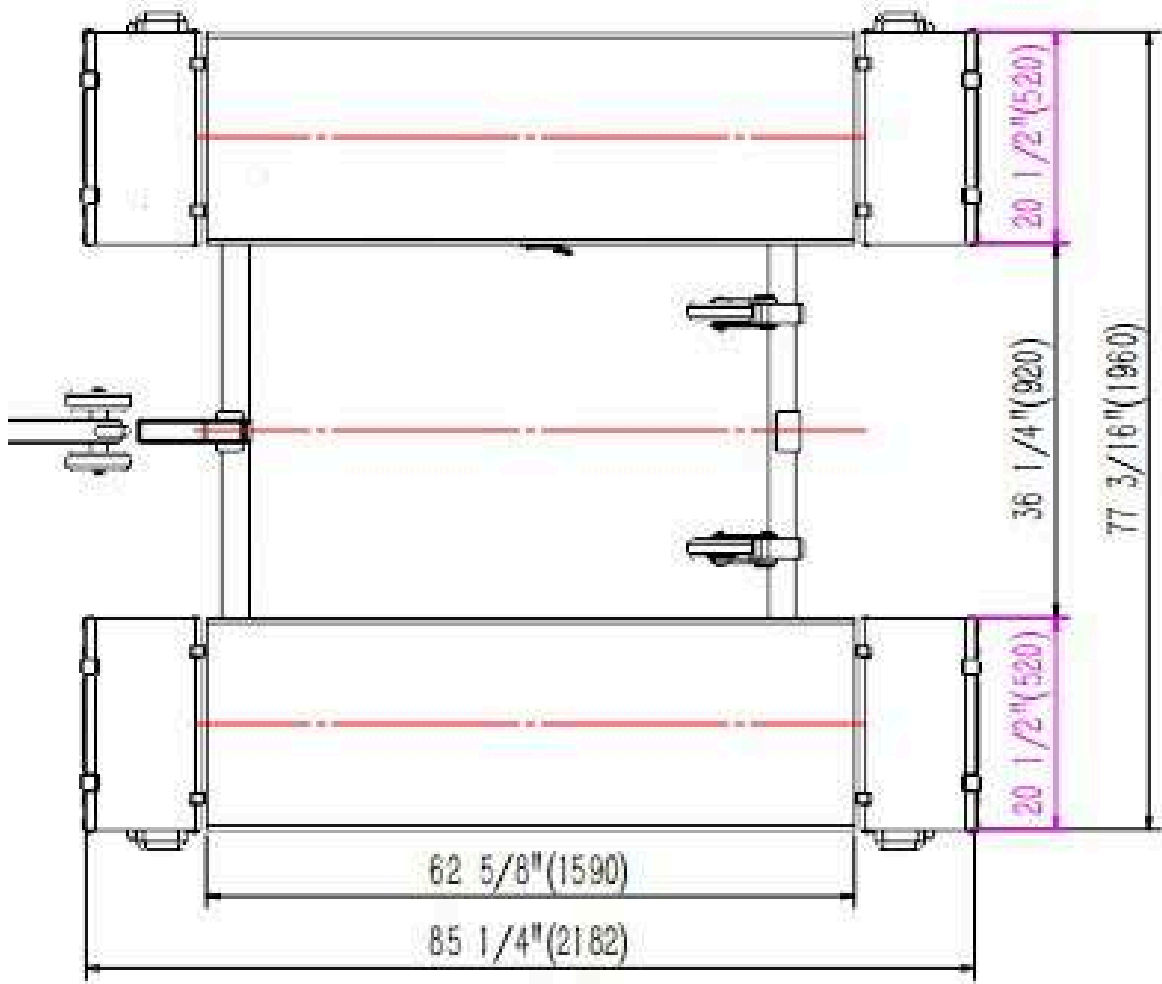
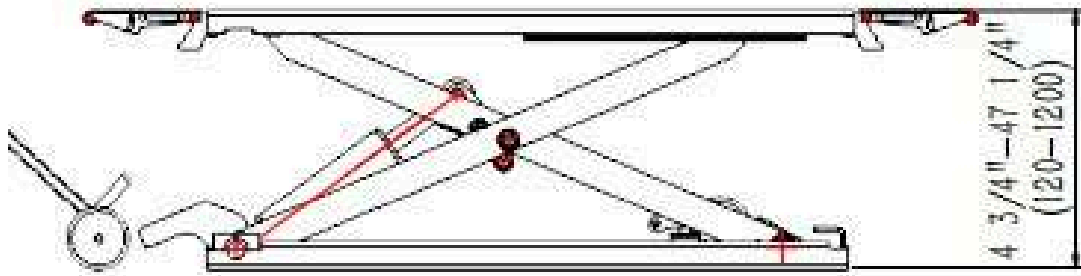

## Frequently Asked Questions

- What thickness of concrete do you recommend?
  - We recommend 6-12 inches reinforced concrete that has cured for at least 28 days.
- What is the recommended PSI for the concrete?
  - We recommend a psi of 3,000
- Does the lift come with anchor bolts and how many?
  - Yes the lift comes with Anchor Bolts. There will be 16 in total
- What are the specs of the Anchor Bolts?
  - The Anchor bolts are 3/4 diameter 6" long anchors bolts
- What are the torque specifications?
  - We recommend 90 foot-pounds, never less than 80 or more than 110 foot-pounds.
- What is the recommended breaker for this lift?
  - We recommend a 30A breaker
- Does this lift come with a plug?
  - The lift does not come with a plug, you will need to get a 220v-250v, 30A plug
- How do I hook up the electrical?
  - Yellow/green is ground, the other 2 are hot
- How long does the power cord reach?
  - The cord is 11 feet
- Is there a way to change the speed of the lift?
  - Yes, with the oil flow valve, you can tighten (clockwise) which will slow the lift, or loosen (counter clockwise) which will speed up the lift.
- How do I lower the lift that is stuck in the air?
  - Release the safety locks and then release pressure of the hydraulic system.

## Warranty

- 5 Years Structure - Platform, Safety Lock System
- 3 Years Hydraulic - Cylinder, Seal Kits, Gear Pump
- 2 Years Electrical - Motor, AC Contactor, PLC, Solenoid, Limiter Switches, Power Light, Buttons, Capacitors
- 1 Year Functional Components - Safety Covers, Hydraulic Hoses, Fittings, Reservoir, Oil/Water Regulator, Slider Blocks
- No Warranty Odds and Ends - Rubber Pads

## Packaging

1 basic unit packed in a large wooden box, including all accessories, with base.  
1 power unit packed in a small wooden box with base.

## Shipping

### CHECK SHIPMENT UPON ARRIVAL

Whereas, we do take precautions to make sure your product gets to you in one piece. There are rare instances where a product may get damaged in transit. You should thoroughly inspect the shipment to make sure all pieces and parts have arrived and document on the bill of lading before accepting. If you are missing any part or damage has occurred, contact us so we can help correct the issue. Please document pictures for records.

## Returns/Cancellations/Refunds

- Returns are only accepted within 14 days from the delivery date, buyer pays return shipping which is non-refundable unless the item sent is incorrect or faulty.
- Merchandise must be unused and packed with the original packages.
- Proof of payment must accompany the return.
- All returned merchandise are subject to inspection. If you are entitled to a refund then we will refund the price of your item.
- We **CHARGE 30% HANDLING & RESTOCKING FEE** if you want to return or cancel the order after we ship out the item. If you choose to cancel your order before we ship it out, your money will be refunded minus a \$250 processing fee.
- Refunds are usually processed within 7 working days of receipt. However, during busy periods this may take longer. We will contact you via email as soon as we have processed your return. Please make sure that your inbox can receive emails from sales@stratusautoequip.com, as this is the email address that we will use to contact you.
- We only offer refunds onto the original payment method used to make the order.

## Parameters

Model	MS9000XT	MS9000X
Rated Lifting Capacity	9,000 lbs	
Driving Mode	Electro Hydraulic Drive	
Lifting Height	47 1/4" (1200 mm)	
Overall Length	85 1/4" (2182 mm)	
Overall Width	77 3/16" (1930 mm)	
Platform Length	62 5/8" (1590 mm)	
Platform Width	20 1/2" (520 mm)	
Motor Parameters	220V / 110V, 202 KW	
Hydraulic Oil	46 # / 68 #	
Equipment Weight	1,631 LBS (740KG)	

## Features







Moveable Ramp which can be used as extension board  
Monolithic base-plate without splice  
Stable and reliable control system  
Aluminum alloy motor with low noise and fast heat dissipation

## Installation

Only skilled technicians, appointed by the manufacturer or authorized dealers are to be allowed to carry our installation. Serious damage to people and to the lift can be caused if installations are made by unskilled personnel

**Always refer to the exploded views attached during installation**

## Tools Required

Rotary Hammer Drill D.20		Carpenter's Chalk
Hammer		Screw Sets
Level Bar		Tape Measure (7.5m)
English Spanner (12")		Lock Wrench
Wrench set (10#, 13#, 14#, 15#, 17#, 19#, 24#, 27#, 30#)		Pliers
Ratchet Spanner With Socket (28#)		Socket Head Wrench (3#, 5#, 8#)

## Notice

The lift has been designed to be used in a covered and sheltered place, free of overhead obstructions. The place of installation must not be next to washing areas, painting workbenches, solvent or varnish deposits. The installation near to rooms, where a dangerous situation of explosion can occur, is strictly forbidden. The relevant standards of the local Health and Safety at Work regulations, for instance, with respect to minimum distance to wall or other equipment, escapes and the like, must be observed. All areas next to the lift must be well and uniformly lit.

## Floor Requirements

- The lift should be fixed on a smooth and solid concrete ground with its strength more than 3000psi, tolerance of flatness less than 5mm and minimum thickness of 6 inches (153 mm). New concrete must be adequately cured by at least 28 days minimum.
- Specifications of concrete must be adhered to. Failure to do so could cause lift failure resulting in personal injury or death.
- A level floor is suggested for proper installation. Small differences in floor slope may be compensated for by proper shimming. Any major slope change will affect the level lifting performance. If a floor is of questionable slope considering to pour the new concrete slab.

## Site Layout

- Now locate the lift according to the floor plan (Figure 3), use a carpenter's chalk line to layout a grid for the column locations.
- After the column locations are properly marked, use a chalk or crayon to make an outline of the columns on the floor at each location using the column base plate as a template.
- Double check all dimensions and make sure that the bases of each column are square and aligned with the chalk line.

## Precautions for installation

- Joints of oil hose must be firmly connected in order to avoid leakage.
- All bolts should be firmly screwed up.
- Do not place any vehicle on the lift in the case of trial running.

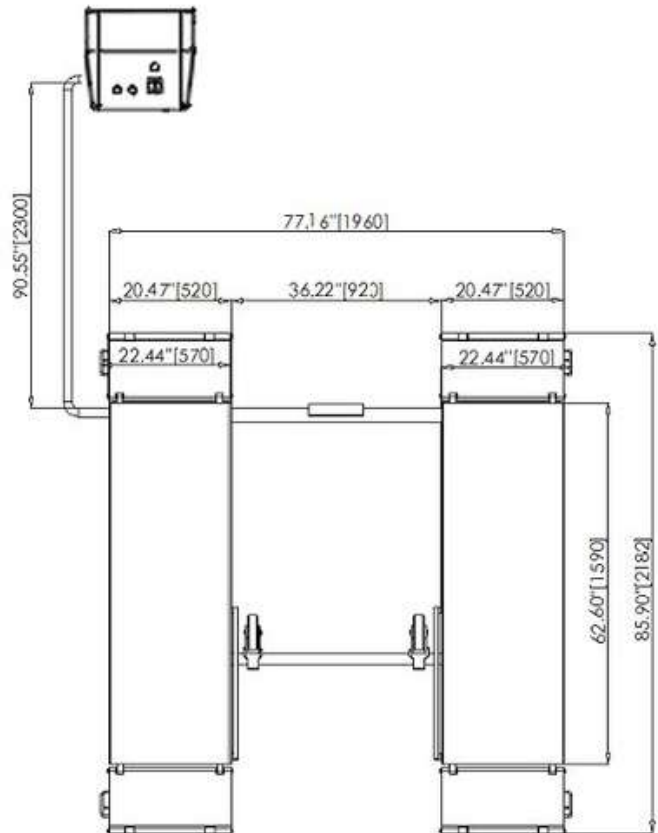



## Equipment Installation

**Please do read and understand this manual thoroughly before completing**

1. Remove the packaging and take the mechanical and hydraulic assembly to the designated installing place.
2. Connect the oil hose to the pump assembly with a proper wrench. (Make sure the hose end is clean).
3. Connect the wires of limit switch to the wiring terminals in the control box. Make sure to connect NO.1 wire with NO.1 terminal, NO.2 wire with NO.2 terminal and so forth.
4. Link the air hose to compressed air source. (This step is only for the type with pneumatic safety lock)
5. Fix the base frame. (Optional)
  - a. This MSL is portable. In other words, users may use it without having it placed and fixed on the ground. Nevertheless, if you want to have it fixed, fix it on a smooth and solid concrete surface.
6. Trial testing with load. (Do not use cars for trial testing). Load applied shall not exceed 9,000 LBS / 2,500KG.
  - a. This step is of particular importance for it can check if the oil hose and air hose are well connected. Connections are qualified when there is no abnormal sound or leakage after having been tested for 2 or 3 times.

## Check After Installation

S/N Check Items	Yes	No
Are both platforms on the same level?		
Are Oil Hoses well connected?		
Are Electrical Connection correct?		
Do Valves on the pump assembly leak?		

## Precautions

- Check all the joints of oil hose. Only when there is no leakage, the lift can start work.
- Do NOT Operate lift is safety device malfunctions
- The machine shall not lift or lower an automobile if its center of gravity is not positioned midway of the rising platforms Otherwise, the manufacturer as well as our dealers will not bear any responsibility for any consequence resulted thereby.
- Operators and other personnel concerned should stand in a safety area during lifting and lowering process.
- When platforms rise to the desired height, switch off the power at once to prevent any wrong operation done by unauthorized people.
- Make sure the safety lock of the lift is engaged before start working under the vehicle and no people under the vehicle during lifting and lowering process.

## Control Box

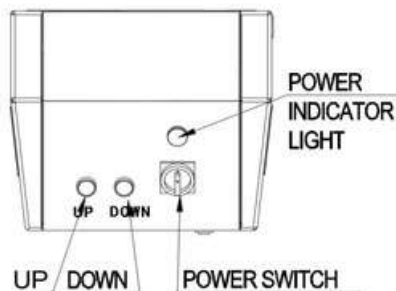
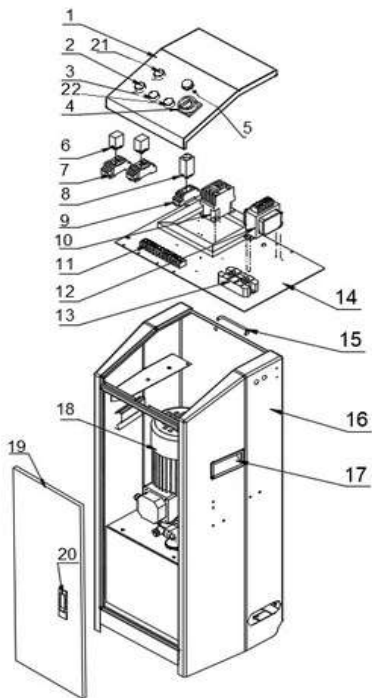

No	NAME	MODEL	Number
1	Upper box		1
2	UP Button		1
3	Lock Button		1
4	Power switch	LJW26-25/2GS	1
5	Power indicator	AD16-22DS	1
6	Relay	VE-R02	2
7	Relay holder	DYF14A	2
8	Time relay	H3Y-2	1
9	Time relay holder	DYF08A	1
10	Contactor	CJX2-1810	1
11	Wiring bank	12P	1
12	Transformer	BK-100VA	1
13	Rectifying bridge	MDQ100-16	1
14	Plate		1
15	Hold hands		1
16	Lower box		1
17	Hold hands		2
18	Moteo pumping station	1.5KW/3.2CC/R	1
19	Box body door		1
20	Lock		1
21	Alarm		1
22	DOWN Button		1

## Operation

### Raise the lift

1. Make sure that you have read and understood the operation manual before operation.
2. Drive and park the vehicle midway between two platforms.
3. Place the four rubber pads under the prop-points of the vehicle and ensure car's gravity has been placed on the rubber pads.
4. Press the UP button on the control box until rubber pads have touched the prop-points of vehicle.
5. Keep on pressing the UP button to lift the vehicle a bit higher from the ground and check again if the vehicle is in a safe position.
6. Having raised the vehicle to the required height, press the "Emergency stop" button before performing maintenance or repair work.

### Lower the lift

1. Switch on (press the "emergency stop button" until the power indicator is on).
2. Press the DOWN button to lower the lift. (For the model with pneumatic safety lock, firstly platforms of the lift will rise about 5cm which is to release the safety lock; for the model without pneumatic safety lock, platforms will go down directly.)
3. Drive away the vehicle.

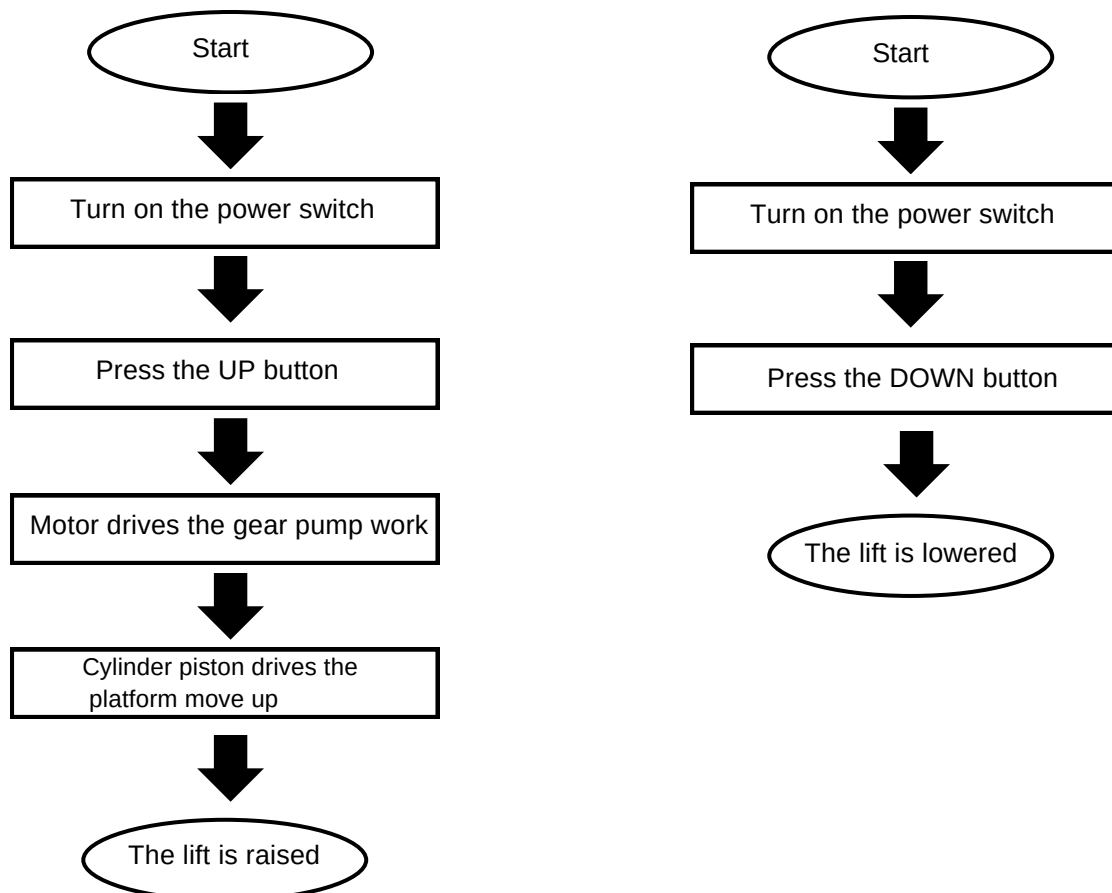

## Emergency Lowing In Case of No Power

- Safety Lock Not Engaged:
  - Tie up the safety teeth on both sides with rope; pull upward the rope making the safety teeth unlocked.
  - Having the safety teeth unlocked, manually loose the core of electro-magnetic valve on the pump assembly.
  
- Safety Lock Engaged:
  - Screw off the fitting (opposite to the oil out-let) to connect a hand pump. (Optional)
  - Connect the hydraulic assembly with the optional hand pump. Press down the handle of the pump to raise the platforms to have the safety teeth unlocked.
  - Tie up the safety teeth with rope and pull up the safety teeth.
  - Use a wrench to loose the core of the electro-magnetic valve to lower the platforms.

## Troubleshooting

**ATTENTION:** If the trouble cannot be fixed by yourself, please do not hesitate to contact us for help. We will offer our service at the earliest time we can. By the way, troubles can be judged and solved much faster if more details or pictures are be provided.

<b>Motor does not run and will not raise</b>	<ol style="list-style-type: none"> <li>1. The wire connection is loose.</li> <li>2. The Motor is burnt</li> <li>3. The limit switch is damaged or the wire connection is loose.</li> </ol>	<ol style="list-style-type: none"> <li>1. Check and make a good connection</li> <li>2. Replace it</li> <li>3. Connect it or replace the limit switch</li> </ol>
<b>Motor runs but will not raise</b>	<ol style="list-style-type: none"> <li>1. The motor run reversely</li> <li>2. Overflow valve is loose or jammed</li> <li>3. The gear pump is damaged</li> <li>4. Oil level is too low</li> <li>5. The oil hose became loose</li> </ol>	<ol style="list-style-type: none"> <li>1. Check the wire connection</li> <li>2. Clean or adjust it</li> <li>3. Replace it</li> <li>4. Add Oil</li> <li>5. Tighten it</li> </ol>
<b>Platforms go down slowly after being raised</b>	<ol style="list-style-type: none"> <li>1. The oil hose leaks</li> <li>2. The oil cylinder is not tightened</li> <li>3. The single valve leaks</li> <li>4. The overflow valve leaks</li> <li>5. Electrical unloading valve leaks</li> </ol>	<ol style="list-style-type: none"> <li>1. Check or replace it</li> <li>2. Replace the seal</li> <li>3. Clean or replace it</li> <li>4. Clean or replace it</li> <li>5. Clean or replace it</li> </ol>
<b>Raising too slow</b>	<ol style="list-style-type: none"> <li>1. The oil filter is jammed</li> <li>2. Oil level is too low</li> <li>3. The overflow valve is not adjusted to the right</li> <li>4. The hydraulic oil is too hot</li> <li>5. The seal of the cylinder is abraded</li> </ol>	<ol style="list-style-type: none"> <li>1. Clean or Replace</li> <li>2. Add Oil</li> <li>3. Adjust it</li> <li>4. Change the Oil</li> <li>5. Replace the seal</li> </ol>
<b>Lowering too slow</b>	<ol style="list-style-type: none"> <li>1. The throttle valve jammed</li> <li>2. The hydraulic oil is dirty</li> <li>3. The Anti-Surge valve jammed</li> <li>4. The oil hose jammed</li> </ol>	<ol style="list-style-type: none"> <li>1. Clean or Replace</li> <li>2. Change the Oil</li> <li>3. Clean it</li> <li>4. Replace it</li> </ol>

## Maintenance

Easy and low cost routine maintenance can ensure the lift work normally and safely. Following are requirements for routine maintenance. You may choose the frequency of routine maintenance by consulting your lift's working conditions and time.

- The Following parts need to be lubricated.

S/N	Description
1	Small idler wheel Rotor
2	shaft
3	U-shape block
4	Safety shaft
5	Rotor shaft of oil tank
6	Slider

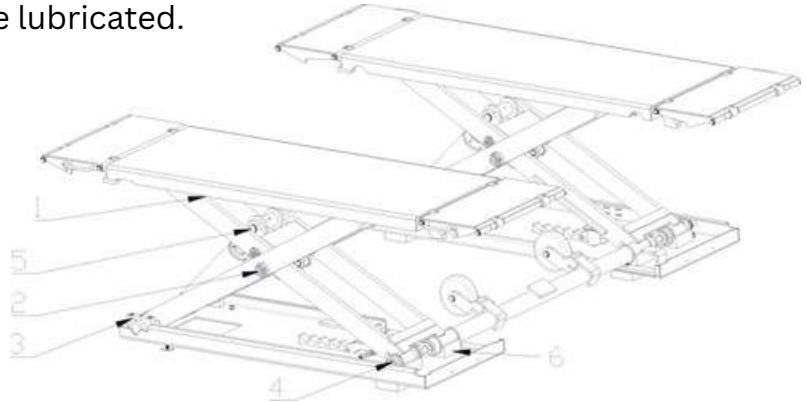

### Daily checking items before operation

- The user must perform daily check. Daily check of safety lock system is very important – the discovery of
- device failure before action could save your time and prevent you from great loss, injury or casualty.
- Before operation, judge whether the safety lock is engaged by sound.
- Check whether oil hose well connected and whether it leaks or not.
- Check the electrical system.
- Check whether plug bolts firmly screwed.
- Check if safety teeth and safety block matched well or not.

### Weekly checking items

- Check the flexibility of moving parts.
- Check the working conditions of safety parts.
- Check the amount of oil left in the oil tank. Oil is enough if the platforms can be raised to highest position.
- Otherwise, oil is insufficient.
- Check whether plug bolts firmly screwed.

### Monthly checking items

- Check whether plug bolts firmly screwed.
- Check the tightness of the hydraulic system and screw firm the joints if it leaks.

### Yearly checking items

- Empty the oil tank and check the quality of hydraulic oil.
- Wash and clean the oil filter.

**If users strictly follow the above maintenance requirements, the lift will keep in a good working condition and meanwhile accidents could be avoided to a large extent.**

# Automotive Lift Institute Store

You probably checked the [ALI's Directory of Certified Lifts](http://www.autolift.org/ali-directory-of-certified-lifts/) (www.autolift.org/ali-directory-of-certified-lifts/) before making your most recent Lift purchase, but did you know the [ALI Store](http://www.autolift.org/ali-store/) (www.autolift.org/ali-store/) offers a wide variety of professional, easy-to-use, and reasonably priced training and safety materials that will make your garage a safer place to work?

The ALI Store is your trusted source for workplace safety!



**Lifting It Right Online Certificate Course.** Make *sure* you and your people are lifting vehicles the right way.



**ALI Lift Inspector Certification Program Registration.** Become a **ALI Certified Lift Inspector.**

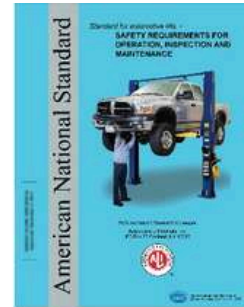

**ANSI/ALI ALOIM Standard for Automotive Lifts.** Safety Requirements for Operation, Inspection, and Maintenance.

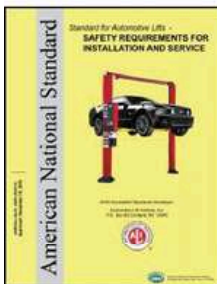

**ANSI/ALI ALIS Standard.** Safety Requirements for Installation and Service.

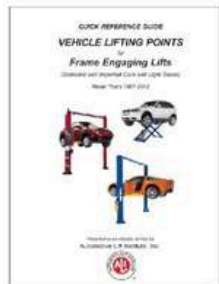

**Guide to Identifying Vehicle Lifting Points for Frame-Engaging Lifts.** Don't eyeball your lifting points, *know* where they are.



**Lift Operator Safety Materials.** Five safety documents in a single package.

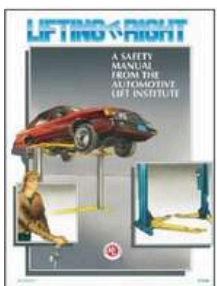

**Lifting It Right.** A hardcopy version of the *Lifting It Right* safety manual from the Automotive Lift Institute.



**Uniform Warning Labels and Placards for 2-Posts.** Labels in Mandarin, French Canadian, and Spanish are also available.



**Safety Tips Card.** Reminds your people of 13 key safety tips to follow daily.

Visit today and get the training and materials you need to worksafely:

[www.autolift.org/ali-store/](http://www.autolift.org/ali-store/)



## ANNEX

### Packing List of the whole lift

S/N	Name	Drawing # / Spec.	Qty
1	MSL 3 Mechanical Assembly	MSL 3-000	1
2	Mobile Kit		Optional
2.1	Wheel	MSL 3-A25-B1	2
2.2	Prop Through	MSL 3-A25-B2	1
2.3	All Directional Wheel	MSL 3-A25-B3	1
3	Feet Protector	MSL 3-A1-B7	2
4	Hydraulic System	MSL 3-A24	1
5	Inside Hex Screw	M8*12	4

## Overall Diagram

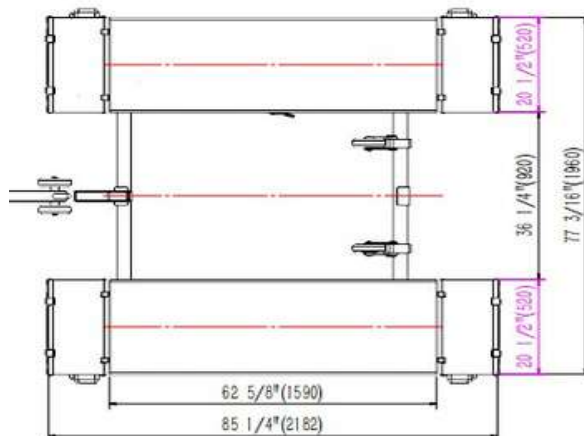
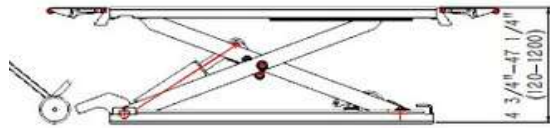

## Pneumatic Working System

- Air filter
- Pneumatic solenoid valve
- Pneumatic cylinder for the main platform
- Pneumatic cylinder for the assistant platform

## Hydraulic Working System

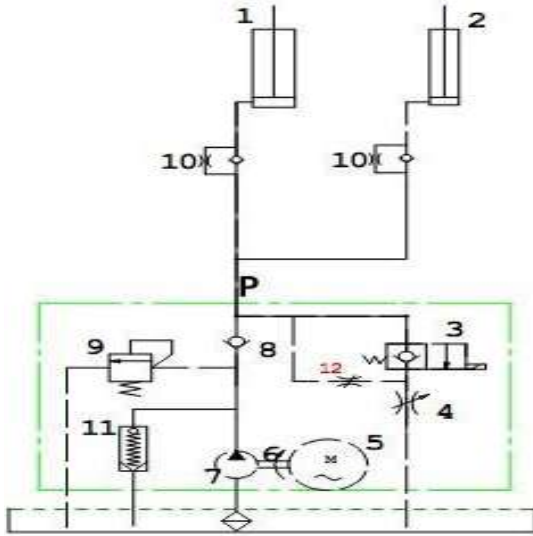

1.	Driving Cylinder	7.	Gear Pump
2.	Assistant Cylinder	8.	One-Way Valve
3.	Electrical Release Valve	9.	Over-Flowing Valve
4.	Lowering Throttle Valve	10.	Anti-Surge Valve
5.	Motor	11.	Cushion Valve
6.	Coupling	12.	Emergent unloading Valve

## Pump

1.	Driving Cylinder	7.	Gear Pump
2.	Assistant Cylinder	8.	One-Way Valve
3.	Electrical Release Valve	9.	Over-Flowing Valve
4.	Lowering Throttle Valve	10.	Anti-Surge Valve
5.	Motor	11.	Cushion Valve
6.	Coupling	12.	Emergent unloading Valve

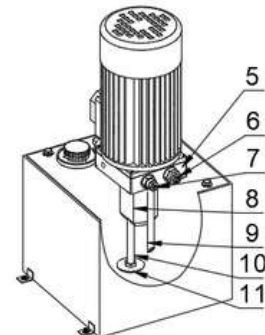
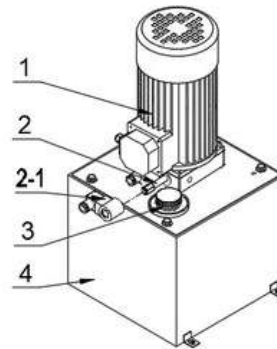

# Wiring Diagram

## ELECTRIC CONTROL PRINCIPLE DIAGRAM OF LIFTING MACHINE

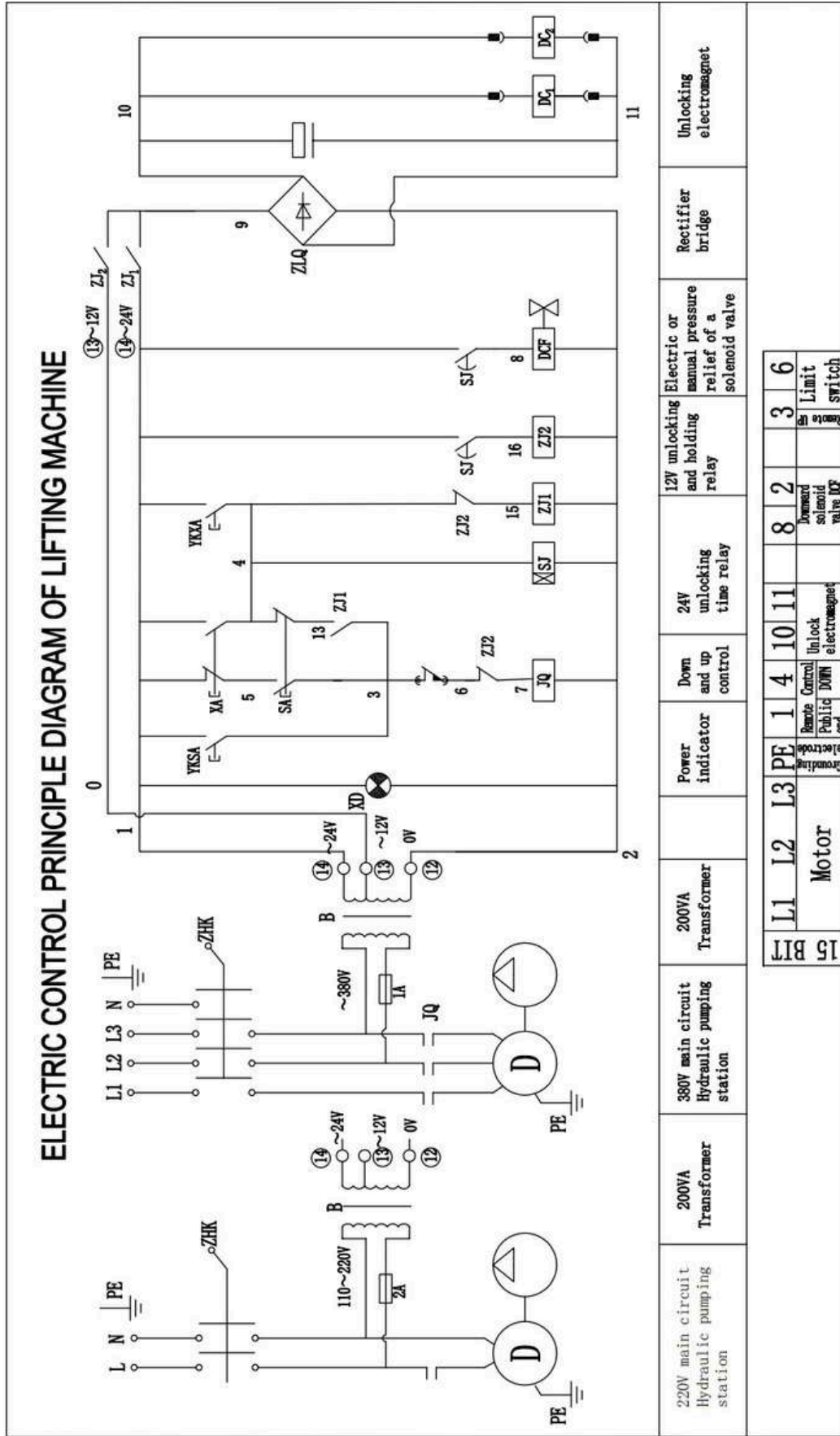

220V main circuit Hydraulic pumping station	200VA Transformer	380V main circuit Hydraulic pumping station	200VA Transformer	Power indicator	Down and up control	24V unlocking time relay	12V unlocking and holding relay	Electric or manual pressure relief of a solenoid valve	Rectifier bridge	Unlocking electromagnet
L	L1	L2	L3	PE	1	4	10	11		
N					Remote Control Public and	Unlock electromagnet	Down solenoid valve	Limit switch		
PE					Grounding electrode					
					Motor					
					15 BIT					

## Wire Connection

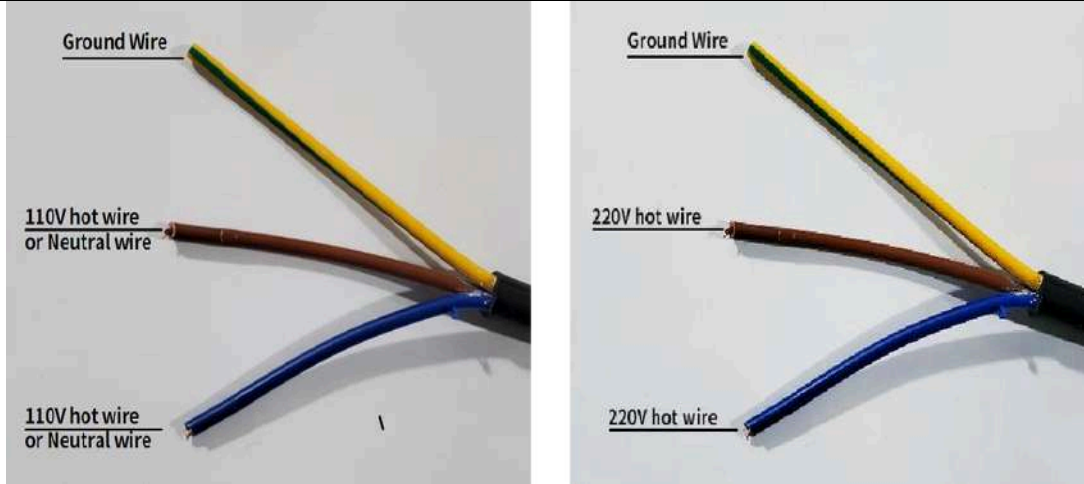

Yellow Green Wire: Ground Wire

Blue and Brown Wire:

1. If the supply voltage is 110V, either one can be 110V hot wire or neutral wire, which means if you want blue wire is 110V hot wire, the brown is neutral wire, if you want brown wire is 110V hot wire, the blue will be neutral wire.
2. If the supply voltage is 220V, both blue and brown wires are hot wire, no neutral wire.

## Spare Parts

Cylinder unlock				
12	Pneumatic solenoid valve	4C210-08/DC24	2	
13	Silencer	G1/8"	2	
14	Pneumatic right angle joint	G1/4"	4	
15	screw	G1/4"	2	
16	Pneumatic control valve	AFR2000	1	
17	Cylinder	CDJ2B16-25-SR	2	
18	Pneumatic right angle joint	M5X0.8-PE6	2	
19	Three connector	PE6	1	
Electromagnet unlock				
12	electromagnet	RX1905 /DC24V	2	

## Lift Diagram

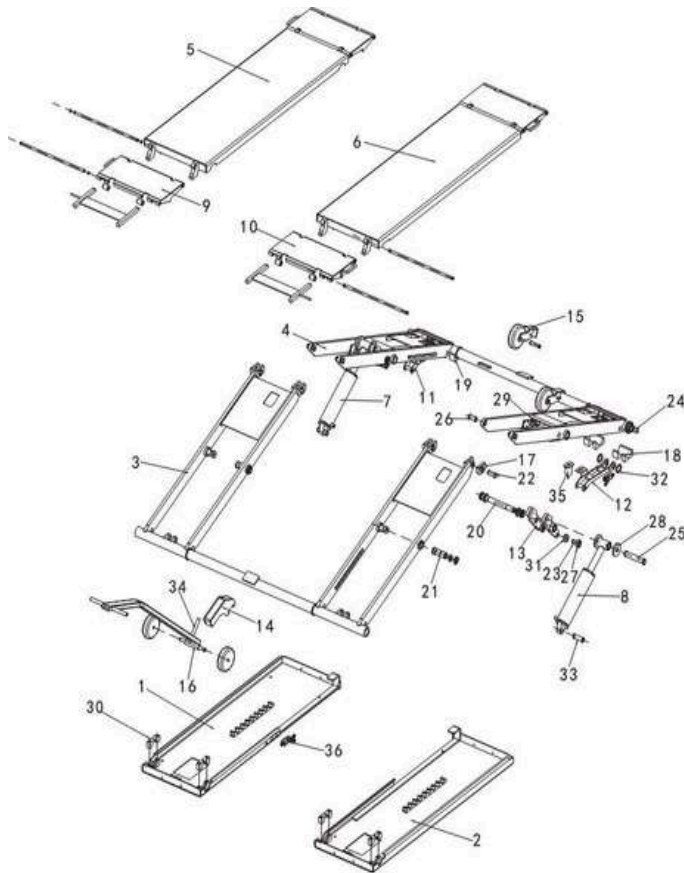

36	Vertical limit switch	3
35	magnetic plug	1
34	The crowbar connects the shaft	1
33	Base connection shaft of the oil cylinder	2
32	Unlock the component gasket	4
31	Short knife ear roller B	4
30	Seamless tube is fixed on the block	4
29	Auxiliary arm compartment	4
28	Short knife-ear oil cylinder spacer sleeve	4
27	Short knife ear roller	4
26	Top slider shaft	4
25	Short blade ear top shaft	2
24	Unlock the blade rotation shaft	2
23	Fixed shaft of the bottom roller	4
22	Sliding shaft	4
21	Main center axis	4
20	The center shaft of the booster arm	2
19	The slide block B	2
18	The slide block A	2
17	On the slider	8
16	Craystick welding combination	1
15	Wheel connection block assembly combination	2
14	Solder joint combination of crowbars	1
13	Short blade and ear welding combination	2
12	Welding combination of the secondary solenoid valve plate	1
11	Welding combination of the main solenoid valve plate	1
10	Running board left assembly combination	2
9	Running board right assembly combination	2
8	Ultra thin cut left cylinder	1
7	Ultra thin cut right cylinder	1
6	Secondary cover plate welding combination	1
5	Welding combination of the main cover plate	1
4	Inner knife arm welding combination	1
3	External knife arm welding combination	1
2	Auxiliary bottom plate welding combination	1
1	Main bottom plate welding combination	1
NO	PART LIST	QUA

## Size & Weight Requirements on Vehicles

Note: Offers may differ as per different requirements on the version.

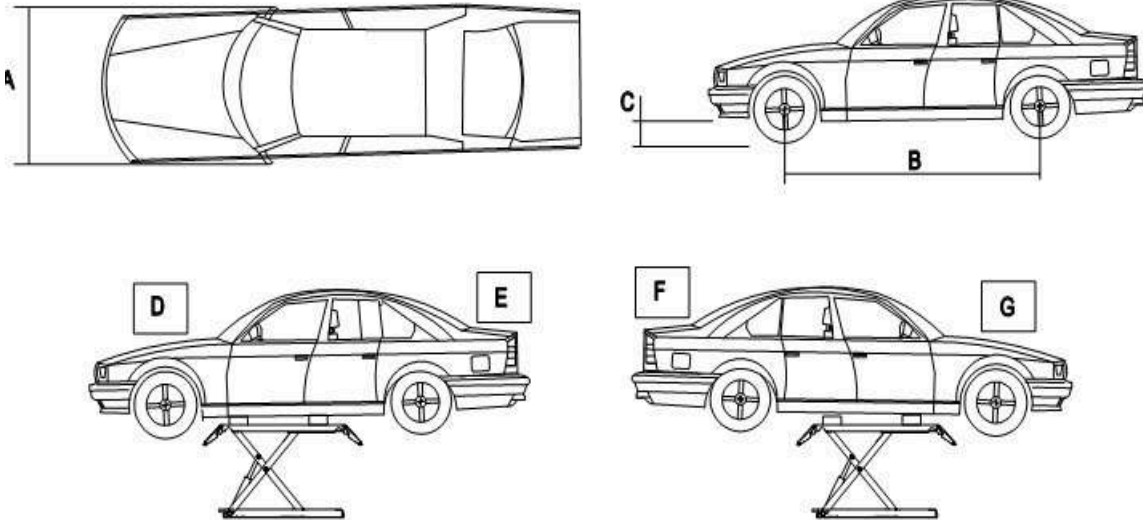

Model	A (Inch)	B (Inch)	C (Inch)	D (LBS)	E (LBS )	F (LBS)	G (LBS)
SAE-MS900 0XT	74 13/16	114 3/16	4 5/16	5291	3527	5291	3527

## Special Notes

### Environmental damage :

- Only appropriately trained personnel may dismantle and dispose of the unit.

### Dismantling:

- To dismantle the product, proceed as follows: ELECTRICAL HAZARD!
- When carrying out any decommissioning and dismantling work on the unit, switch off all power supply connections, ensure they cannot be switched on unintentionally and verify that they have been
- disconnected. Earth and short-circuit them, and cover or otherwise isolate any neighboring live parts. Failure to do so may lead to serious injuries or death.
- HIGH PRESSURE HAZARD.
- When carrying out any unit decommissioning and dismantling work, close off and empty all the connection pipes until the pressure is the same as the ambient air pressure. Failure to do so may lead to injury.
- Make sure that the hydraulic circuit has been switched off. Close all hydraulic shut-off valves.
- Disconnect all connections, making sure at the same time, that no operating materials escape, such as oil, refrigerant and water- glycol mixture.
- Loosen the connection to the base. PERSONAL INJURY!
- Secure the unit against slipping. The unit is ready for transporting.
- It is important that all transport information is observe

### Disposal:

- A specialist company with the appropriate competence must dispose of the unit and individual components. This technical services department must ensure that:
  - the components are separated according to material types
  - that the operating materials are sorted and separated according to their properties. ENVIRONMENTAL DAMAGE.
- Dispose of all components and operating materials (such as oil, refrigerant and water-glycol mixture) separately according to material and in line with local laws and environmental regulations.

### Noise Declaration:

- Sound power level: LWA<85dB Accompanied uncertainly K=4 dB
- With the rated load, the pump motor rotate.
- Applied operating conditions are:
- According the test report, the operating position have the max noise value, but the noise risk is not the obvious hazard of the lift and the noise value is not big more to hurt operator.
- If the noise is higher than the value, the lift must be stopped and check the trouble and repair.