

8 7 6 5 4 3 2 1

D

D

C

C

B

B

A

A

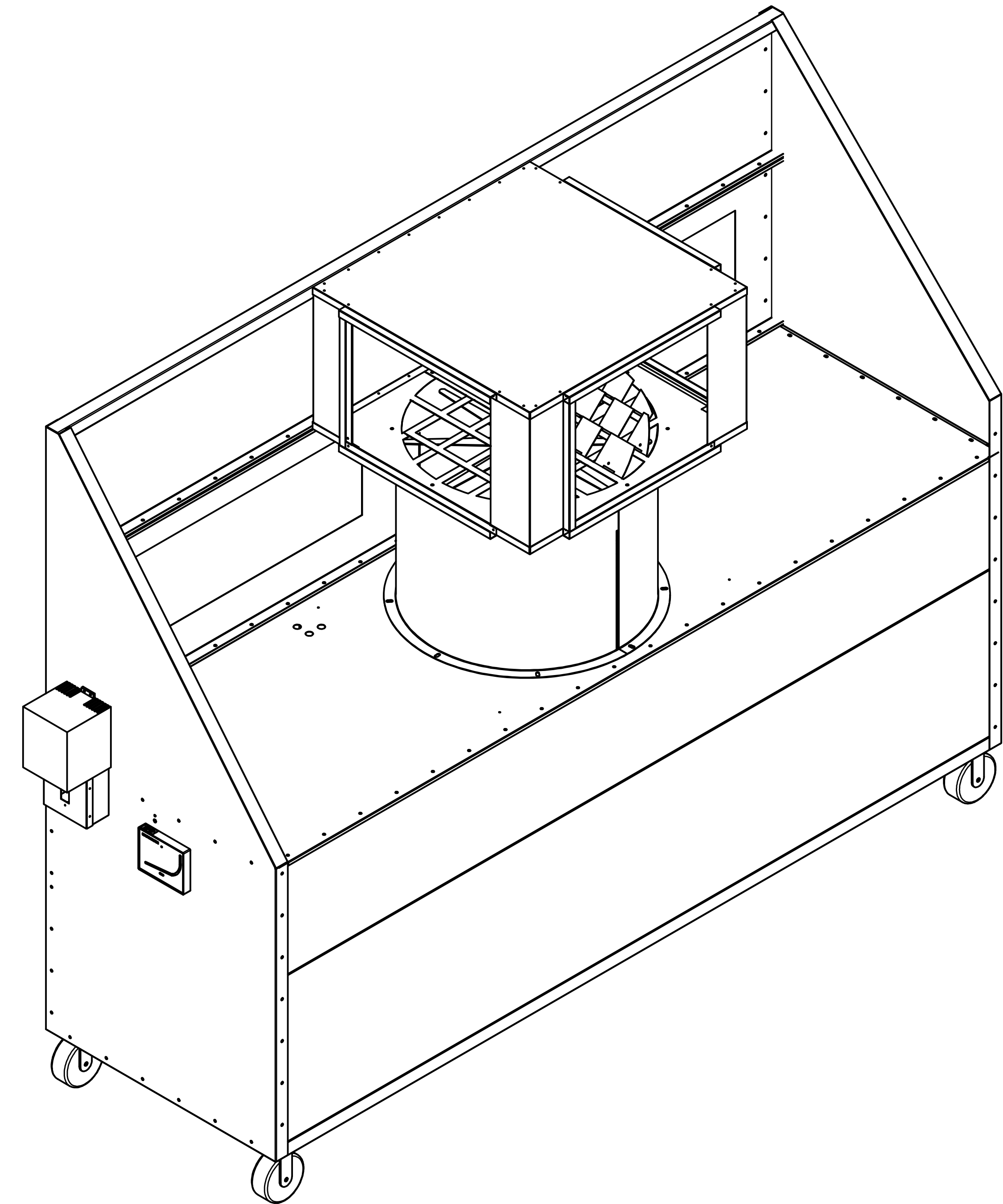
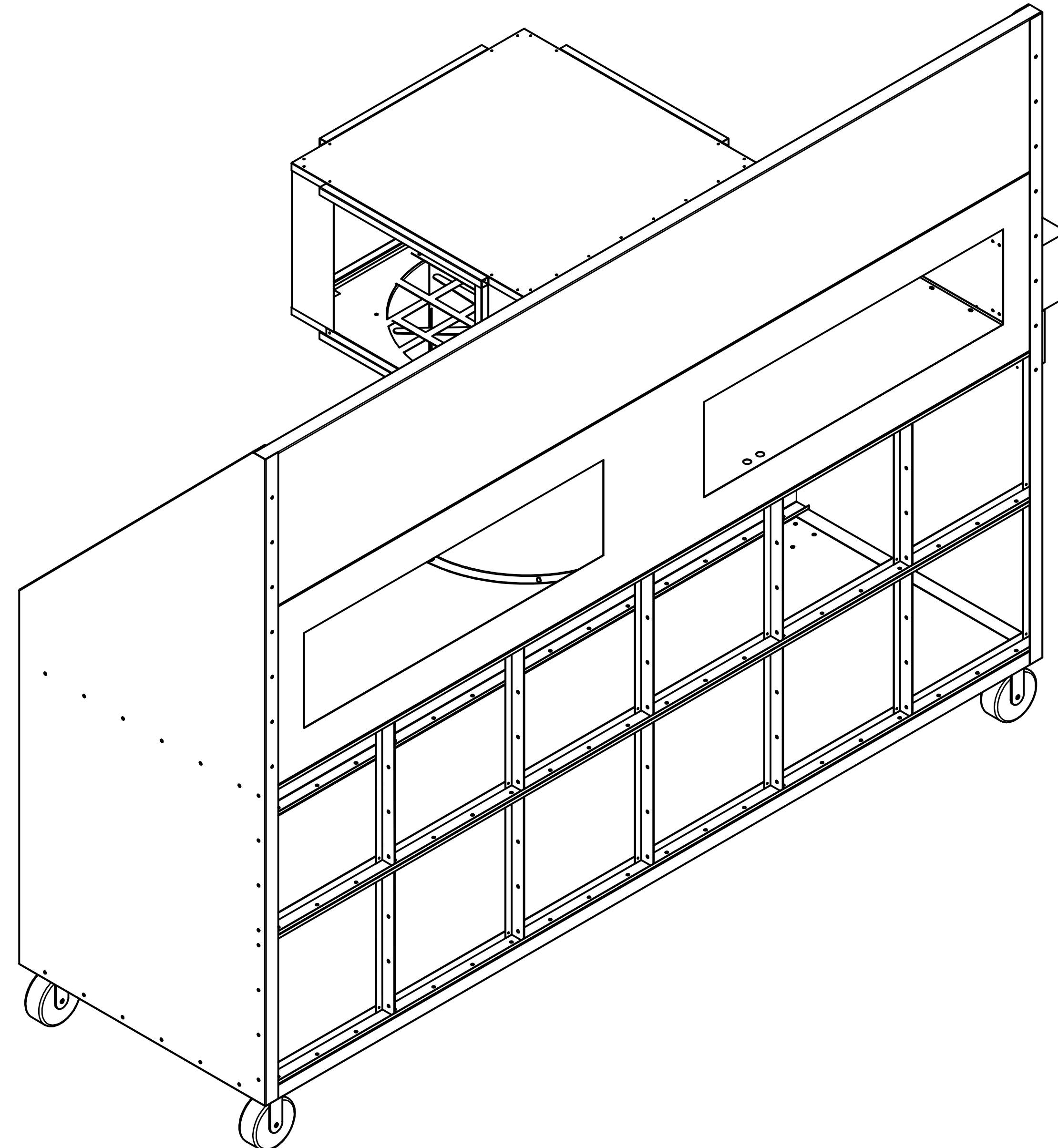

THIS DOCUMENT CONTAINS CONFIDENTIAL AND PROPRIETARY INFORMATION THAT CANNOT BE REPRODUCED OR DIVULGED, IN WHOLE OR IN PART, WITHOUT WRITTEN AUTHORIZATION FROM RGI SPRAY BOOTHS

DRAWN Curtis K	7/25/2024	RGI SPRAY BOOTHS	
CHECKED		TITLE	
QA		MOBILE PREP STATION	
MFG		120 X 94 X 38	
APPROVED		PART #	DWG NO
		MOBILE PREP LIGHTED 120 X 94 X 38	
		SCALE 1 / 10	SHEET 1 OF 10

8 7 6 5 4 3 2 1

8 7 6 5 4 3 2 1

D

D

MOBILE PREP STATION CONSTRUCTION:

CONSTRUCTION: 18 GA. ZINC GALVANIZED STEEL PANELS, PRE PUNCHED AND ASSEMBLED WITH 1/4 NUTS AND BOLTS

POST EXHAUST FILTERS:

20" X 25" PAINT POCKETS

EXHAUST FILTERS:

20" X 20" FIBER GLASS FILTERS

MECHANICAL:

HEAVY DUTY TUBE AXIAL TYPE WITH NON SPARKING ALUMINUM BLADES, ENCLOSED BELTS AND BALL BEARINGS.

(1) 2HP 3PH MOTOR VOLTAGE - (2) 120V CONNECTION DELIVERS: 10,310 CFM EACH @ 0.250" S.P.

(1) 48" X 12" LED LIGHT FIXTURE 2/ 4 LAMPS 120V

AC MOTOR SPEED CONTROL: ADJUSTABLE FREQUENCY DRIVE 3PH AC MOTORS NEMA 4X / IP 65

(1) 4 HR COUNTDOWN TIMER LIGHT SWITCH

TOP VIEW:

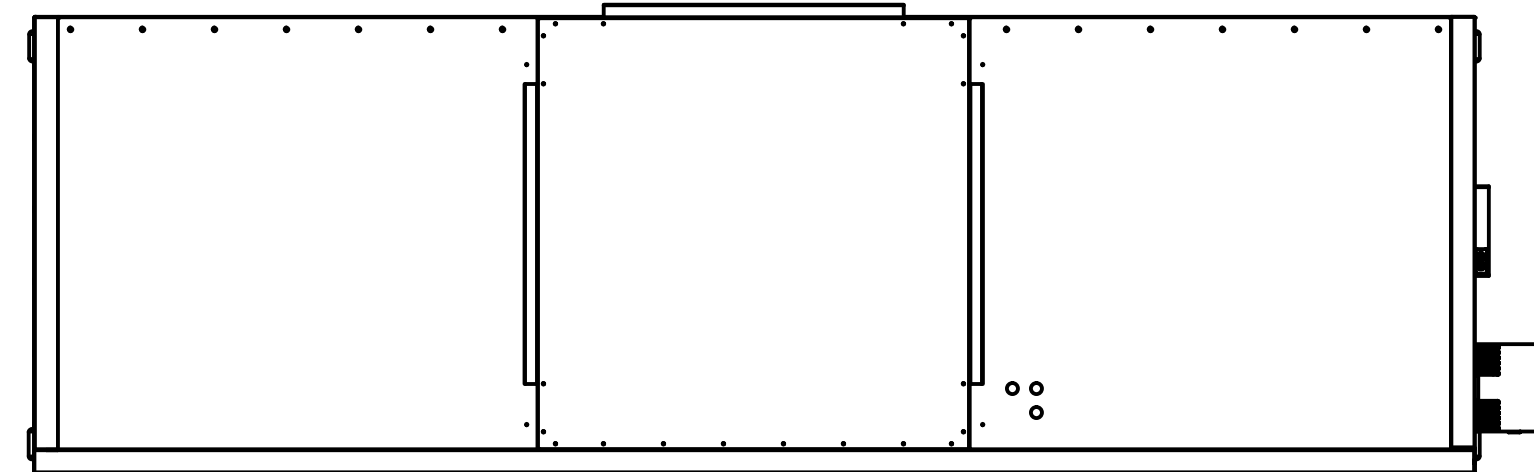

SIDE VIEW:



FRONT VIEW:

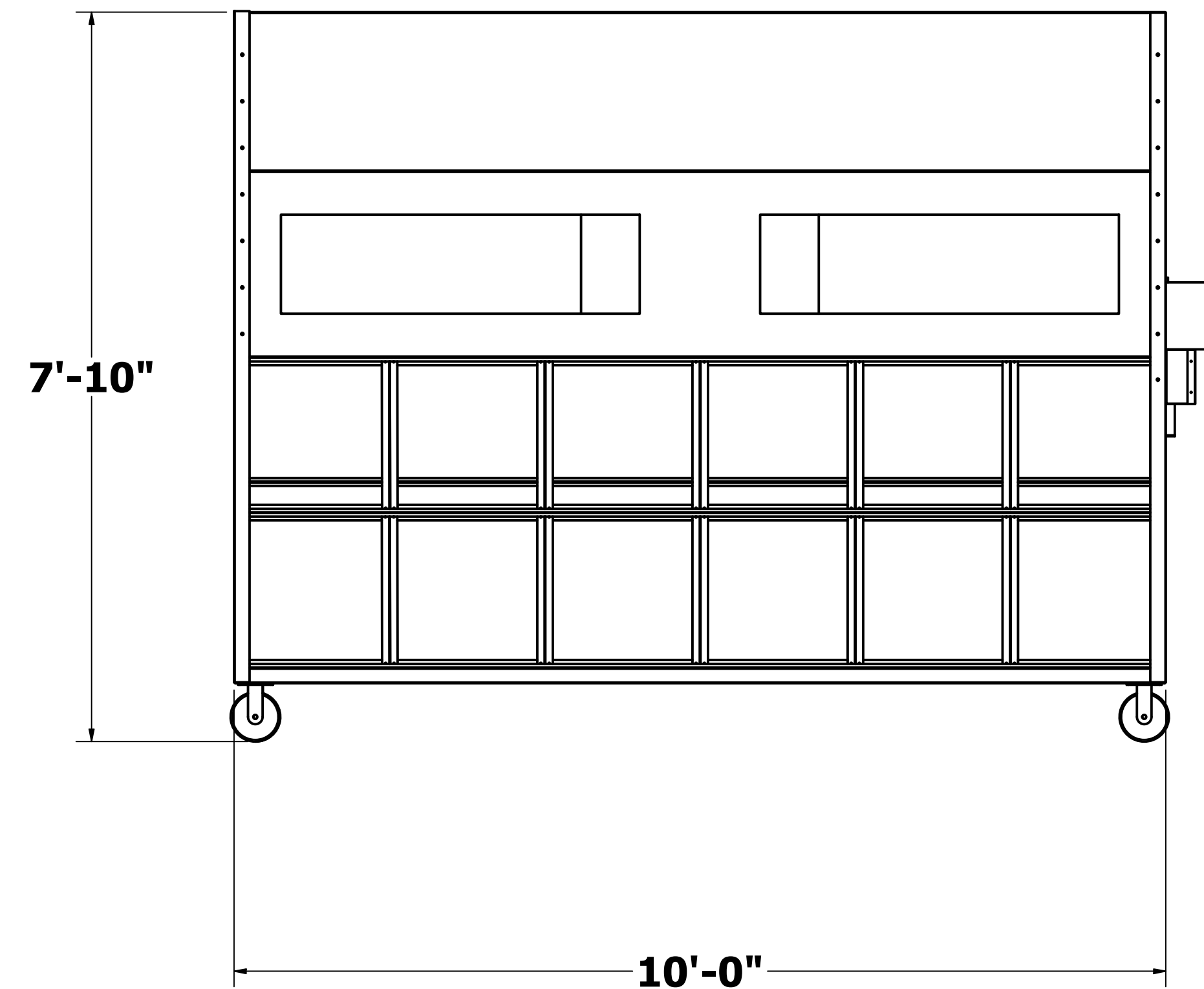

SIDE VIEW:

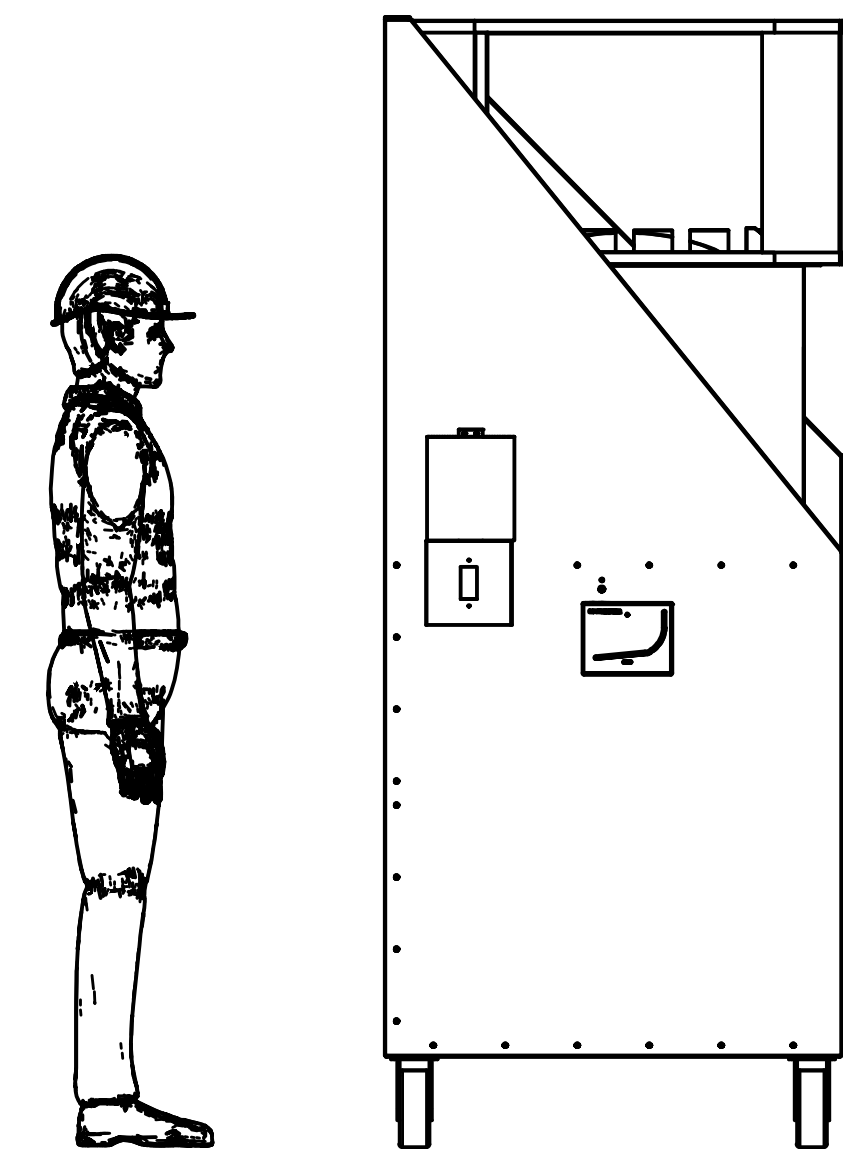

C

C

B

B

A

A

8 7 6 5 4 3 2 1

DRAWN Curtis K	7/25/2024	RGI SPRAY BOOTHS	
CHECKED		TITLE	
QA		MOBILE PREP STATION	
MFG		120 X 94 X 38	
APPROVED		PART #	DWG NO
			REV
		MOBILE PREP LIGHTED 120 X 94 X 38	
		SCALE 1 / 16	SHEET 2 OF 10