

BendPak®

12APX SERIES

12APX | 12APX-192

MADE STRONG™



**ADAPTABLE DESIGN
SYMMETRIC OR ASYMMETRIC**

**12,000 Lb.
Lifting Capacity**

**360° ASARS
AUTOMATIC SWING ARM
RESTRAINT SYSTEM**



BI-METRIC™ Lifting



**Low-Pro™
Triple-Telescoping Arms**



Performance Guaranteed*

1-800-253-2363 | WWW.BENDPAK.COM

© 2024 BendPak Inc. BendPak is a registered trademark.

*For comprehensive details about BendPak's 5-2-1 warranty, visit www.bendpak.com/support/warranty/.



RISE TO NEW HEIGHTS



OVER
82"
OF MAX
LIFTING
HEIGHT *

* Maximum Lifting Height includes both tall and medium adapters stacked. Specifications subject to change without notice.

A New Paradigm in Lifting

Experience the future of auto repair with BendPak's groundbreaking AP Series of two-post lifts. Crafted with cutting-edge technology, these lifts represent an evolution in car lift engineering. Engineered for extreme durability, high loads, and operator safety, the AP Series represents the epitome of efficiency and convenience.

With a carrying capacity of 12,000 lbs. and featuring a revolutionary design that combines the best qualities of today's two-post lift types, the 12APX lifts are purposefully built to adapt alongside the vehicles they service. Whether you need wide or narrow installation, BendPak 12APX lifts offer unmatched versatility in a configurable package. The 12APX and 12APX-192 are high-rise lifts which have been designed to accommodate mechanics out there who are constantly working in uncomfortable conditions on the job. By offering plenty of working space underneath the vehicle, operators can comfortably work on vehicles like high-roof cargo vans.

With an expandable top beam and Bi-Metric™ arms, the 12APX and 12APX-192 are able to cater to virtually every vehicle lifting requirement, whether that's symmetric or asymmetric. Boasting a simple yet sophisticated design, these lifts keep service and maintenance costs down to a minimum, delivering lower operating expenses and increased productivity.

Bi-Metric™ Swing Arms

Exclusive BI-METRIC™ adaptable swing arms feature a 2-in-1 design which gives operators the option of loading vehicles either symmetrically (centerline of vehicle at column) or asymmetrically (centerline of vehicle behind column). By not having to switch out arms, you'll be able to service vehicles faster than ever before.



Asymmetric Configuration

Symmetric Configuration

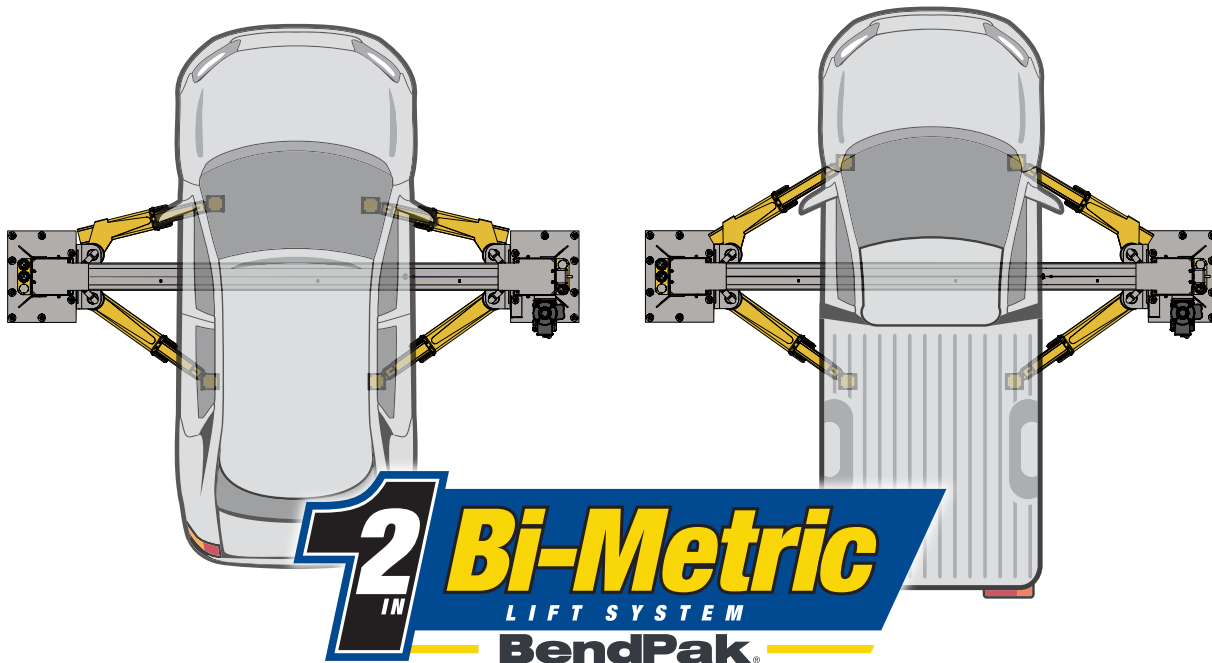

Automatic Arm Restraint System Prevents Unplanned Movement

For decades, swing arm restraints have been a staple on two-post lifts, serving to minimize the risk of arms shifting during vehicle loading and servicing. However, traditional systems often struggled to withstand the sudden and unexpected forces exerted when vehicles shifted on the support pads or adapters of the extended swing arms. This issue typically arose from improper loading or the addition or removal of heavy drivetrain components, leading to an unexpected shift in the vehicle's center of balance.

The AP Series of two-post lifts feature BendPak's revolutionary Automatic Swing Arm Restraint System (ASARS). Unlike traditional systems, ASARS has been specifically engineered to withstand the elevated pushing and pulling forces encountered during heavy vehicle servicing.

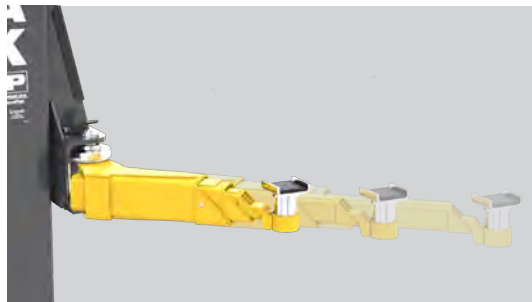
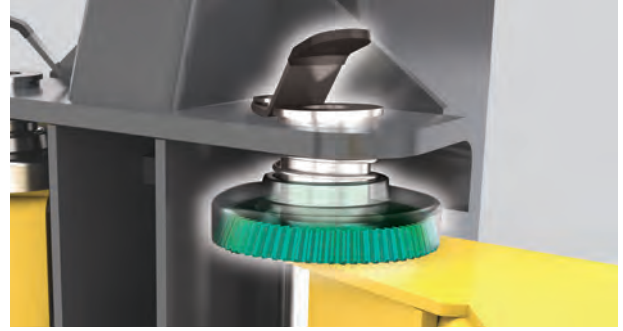

Triple-Telescoping Nested Swing Arm Design

Revolutionary and patented swing arms are specifically tailored for varying vehicle lifting points. Unlike traditional two-post lift arms, 12APX arms retract shorter and extend farther; offering lift operators a myriad of lift arm positioning options — it's like having the best of all worlds.

The innovative three-stage arms achieve more telescoping movement due to their patented nesting feature that results in greater retraction and farther reach. Inner sliding arm movement is no longer impeded by arm end plates, tube closeouts, or even the arm pivot pin itself. The inner tubes retract fully through the back of the arm assembly end even beyond the arm pin, resulting in more achievable retraction and extension.

Low Profile Arms

Our exclusive Low-Pro™ swing arms feature telescoping channels which have a shorter profile and a dropped-end pad receiver resulting in better serviceability on lowered chassis-height vehicles. They access hard-to-reach lift points with less hindrance providing increased versatility and less chance of damage to vehicle side skirts, running boards or ground effects.

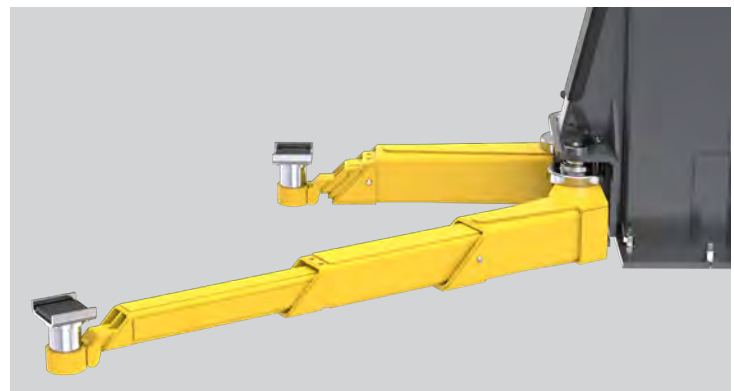

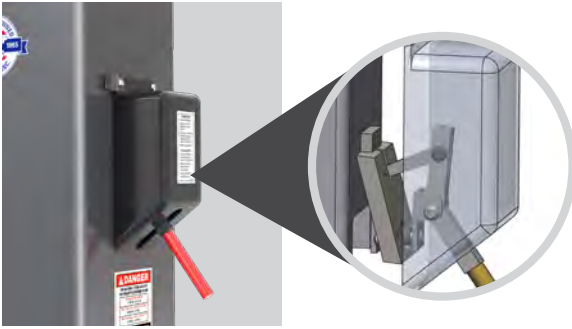

Innovative Safety Lock System

The patented automatic safety lock system is designed to dramatically improve operator efficiency and safety. The simple yet innovative design ensures automatic safety lock engagement during all lift rising operations, and an ergonomic single-point release allows operators to effortlessly release the safety locks during lift descent — literally with a push of a single finger. It's that easy.

Features

- Durable powder coat finish
- Expandable top beam accommodates wide or narrow drive-through configurations
- Double-telescoping screw pads offer increased versatility
- Padded overhead safety shutoff bar
- Exclusive Bi-Metric™ arm design for more versatile arm positioning
- Single-point safety release
- Drop-end arms provide a lower pad height
- Dual hydraulic direct-drive cylinders
- Electric / hydraulic HVLP power system
- Self-lubricating dura-glide UHMW polyethylene bearing system
- Safety locks in each column spaced every 4"
- Automatic arm restraints withstand over 2,000-pounds of side force
- Heavy-duty ½" aircraft-quality equalizer cables
- Oversized cable sheave diameter reduces cable fatigue
- Four-Triple Telescoping Arms

Adapters That Adjust To Your Needs

Every 12APX model comes standard with a 12-piece set of lifting adapters designed to accommodate virtually every chassis configuration. This set includes (4) frame cradle pads, (4) medium stacking adapters, and (4) tall stacking adapters, ensuring enhanced security for lifting heavier vehicles by providing precise and secure frame engagement. For added convenience, a pair of column-mounted racks ensures that adapters are neatly organized and within easy reach. Additionally, we offer other optional accessories such as short stacking adapters, extra-wide frame cradle sets, and an assortment of rubber and pinch-weld pads, all readily available. Unleash the full potential of your lift with our versatile adapter sets.

ACCESSORIES INCLUDED



Drop-In Cradle Pads

(Set of 4)
5215761



5" Tall Adapters

(Set of 4)
5215759



2.5" Medium Adapters

(Set of 4)
5215758



Adapter Holders

(Set of 2)
5210432

SPECIFICATIONS



The height extension kit for the **12APX-192** increases the overall height by 24 inches, providing additional clearance for taller vehicles.



Model	12APX	12APX-192
SKU	5175556	5175557
Max. Lifting capacity	12,000 lbs. / 5,443 kg	
A – Under Clearance ¹ (Top Lock)	75.5 in. / 1,922 mm	
B1 – Max. Lifting Height ² (Top Lock)	79 in. / 2,006 mm	
B2 – Max Rise ³	79.5 in. / 2,018 mm	
C – Max. Lifting Height w/ Adapters ⁴	86.5 in. / 2,210 mm	
D – Min. Height w/ Pad	4 in. / 101.2 mm	
E – Overall Height	169 in. / 4,294 mm	193 in. / 4,904 mm
F – Overall Width	156 in. / 3,959 mm	
G – Width, Outside Posts	143 in. / 3,238 mm	
H – Width, Inside Posts	120 in. / 3,047 mm	
I – Width, Drive-Thru	103 in. / 2,616 mm	
J – Floor to Top Switch	162.50 in. / 4,128.1 mm	186.50 in. / 4,738.5 mm
K – Front Arm Reach (min) ⁵	26 in. / 660.4 mm (min)	55.25 in. / 1,404.2 mm (max)
L – Rear Arm Reach ⁵	29.50 in. / 745.3 mm (min)	60 in. / 1,524.4 mm (max)
Max. load per Lift Arm	3,000 lbs. / 1,361 kg	
Pad Adapters Total Height	7.50 in. / 188 mm	
Time to Full Rise	≈ 45 seconds	
Motor	220 VAC, 60 Hz, 1 Phase	
Sound	<70 dB	

(1) Under Clearance is to the bottom of the lift arms while engaged on top locks. (2) Max Lifting Height is with the locks engaged measured to the top of the pad. (3) Max Rise is distance raised to maximum vertical travel, above locks. (4) Max Lifting height is measured with adapters stacked and on top lock positions. (5) Lift Arms are measured from the Lift Arms axis of rotation to the Frame Cradle Pad mounting pin center. **Specifications subject to change without notice.**

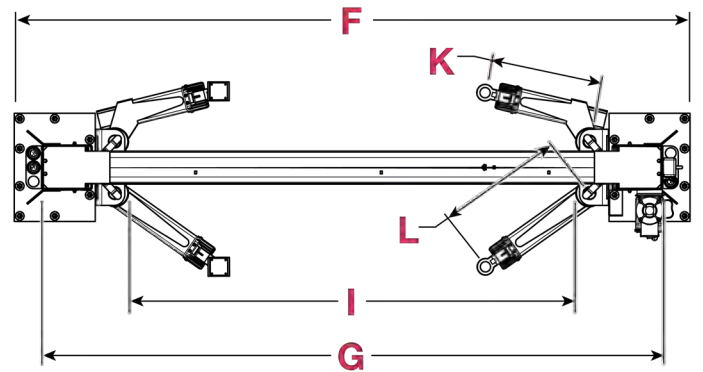
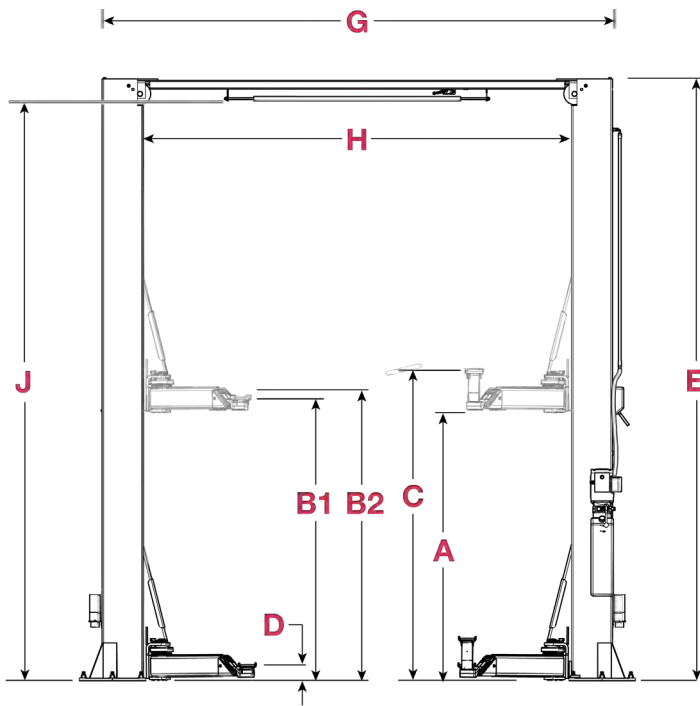

OPTIONAL ACCESSORIES



Quick-Fit
Pinch-Weld Pucks

(Set of 4)
5210263



Quick-Fit
Pinch-Weld Pads

(Set of 4)
5210254



Wide Frame
Cradle Adapters

(Set of 2)
5215761



2.25" Low Adapter

(Set of 4)
5215757



Steel
Lift Pads

(Set of 4)
5215763



Replacement
Urethane Pads

(Set of 4)
5700227



Screw Pads

(Set of 4)
5215762



Other Popular Products From BendPak

Octa-Flex™ Series Revolutionizing Vehicle Service

The world's first two-post lift with eight arms introduces a paradigm shift for servicing both regular and electric vehicles. The EV12DPS can securely hoist up to 12,000 lbs. using its primary arms and an additional 2,500 lbs. with its lift assist arms.



Mobi-EVS™ Series EV Battery Pack and Powertrain Lift Table

The EVS4500 boasts a 4,500-lb. lift capacity and features a compact design which can be easily transported anywhere in the workplace, making it ideal for multi-bay facilities or workplaces with confined areas. Mobi-EVS models feature multiple recessed anchoring locations for accommodating a variety of modular fixtures, adapters, and accessories.

AP-SRT Series Short-Colum/Rise Two-Post Lift

You're not always going to need to stand under a vehicle, and that's where the AP-SRT lifts come in. These short-rise, short-column lifts are perfect for the shop that primarily deals with tire, wheel, and brake service. These short-rise, short-column lifts are the latest addition to the revolutionary AP Series and fit perfectly in shops and low-ceiling garages.



16AP & 20AP Series Super-Duty Two-Post Lift

From heavy-duty fleet service to airport maintenance and emergency vehicle management, BendPak's 16AP and 20AP series tackles them all. With plentiful 16,000- and 20,000-pound lifting capacities and a sizeable assortment of lifting adapters to accommodate virtually every chassis configuration, our Super-Duty AP Series make an ideal supplement to existing fleet operations.

BendPak®

1-800-253-2363 | WWW.BENDPAK.COM

© 2024 BendPak Inc. All rights reserved. BendPak is a registered trademark.

SKU 5900400

Sourcewell 

Awarded Contract
Contact #121223-BND