

THIS DOCUMENT CONTAINS CONFIDENTIAL AND PROPRIETARY INFORMATION THAT
 CANNOT BE REPRODUCED OR DIVULGED, IN WHOLE OR IN PART, WITHOUT WRITTEN
 AUTHORIZATION FROM RGI SPRAY BOOTHS

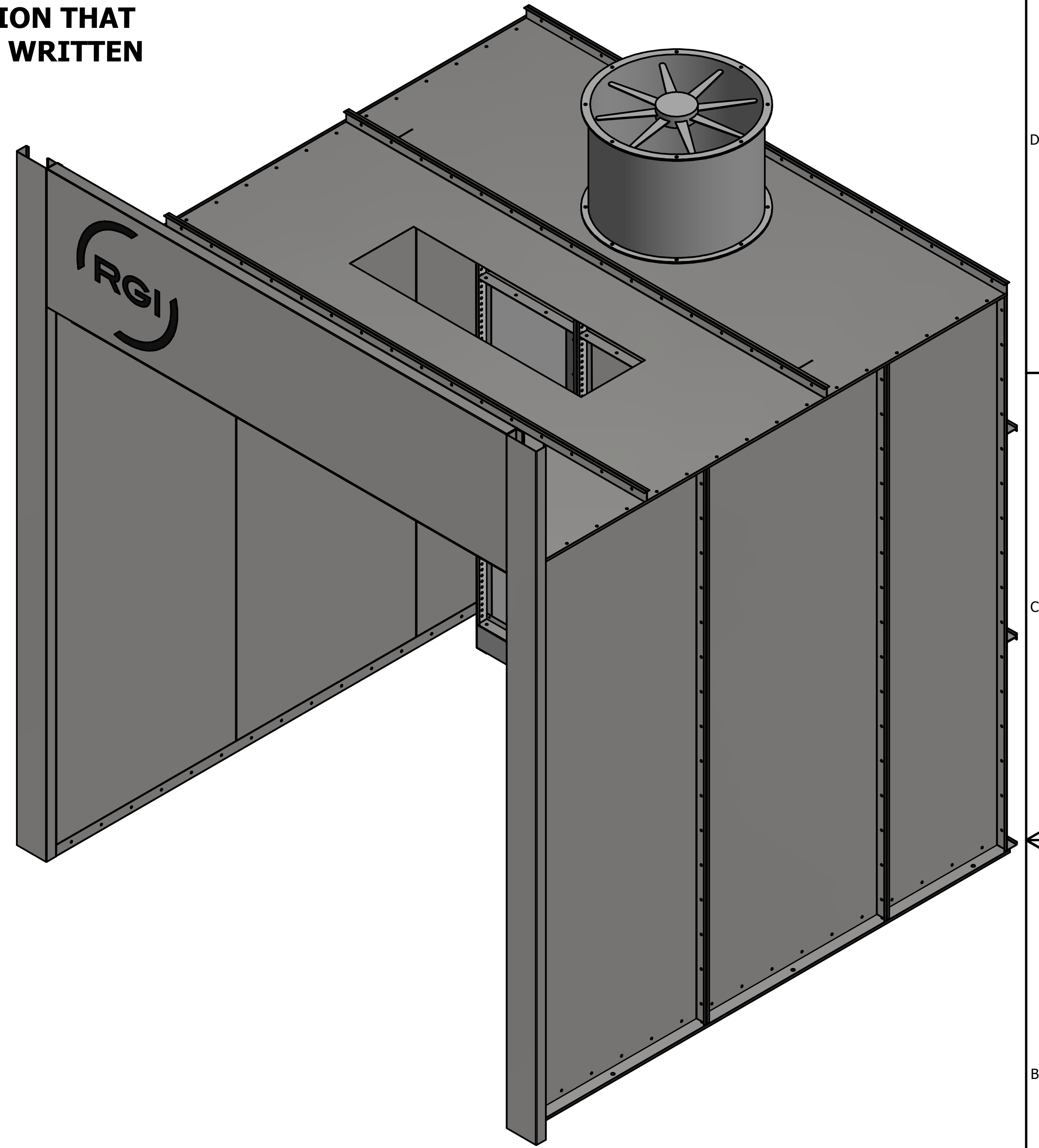

DRAWN DAVID FRISK	8/9/2019	RGI SPRAY BOOTHS	
CHECKED		TITLE	
QA		OPEN FACE 8W X 8H X 8DP	
MFG		SIZE D	DWG NO
APPROVED		OPEN FACE 8W X 8H X 8DP	
MATERIAL		SCALE 1 / 12	REV
		SHEET 1 OF 1	

THIS DOCUMENT CONTAINS CONFIDENTIAL AND PROPRIETARY INFORMATION THAT CANNOT BE REPRODUCED OR DIVULGED, IN WHOLE OR IN PART, WITHOUT WRITTEN AUTHORIZATION FROM RGI SPRAY BOOTHS

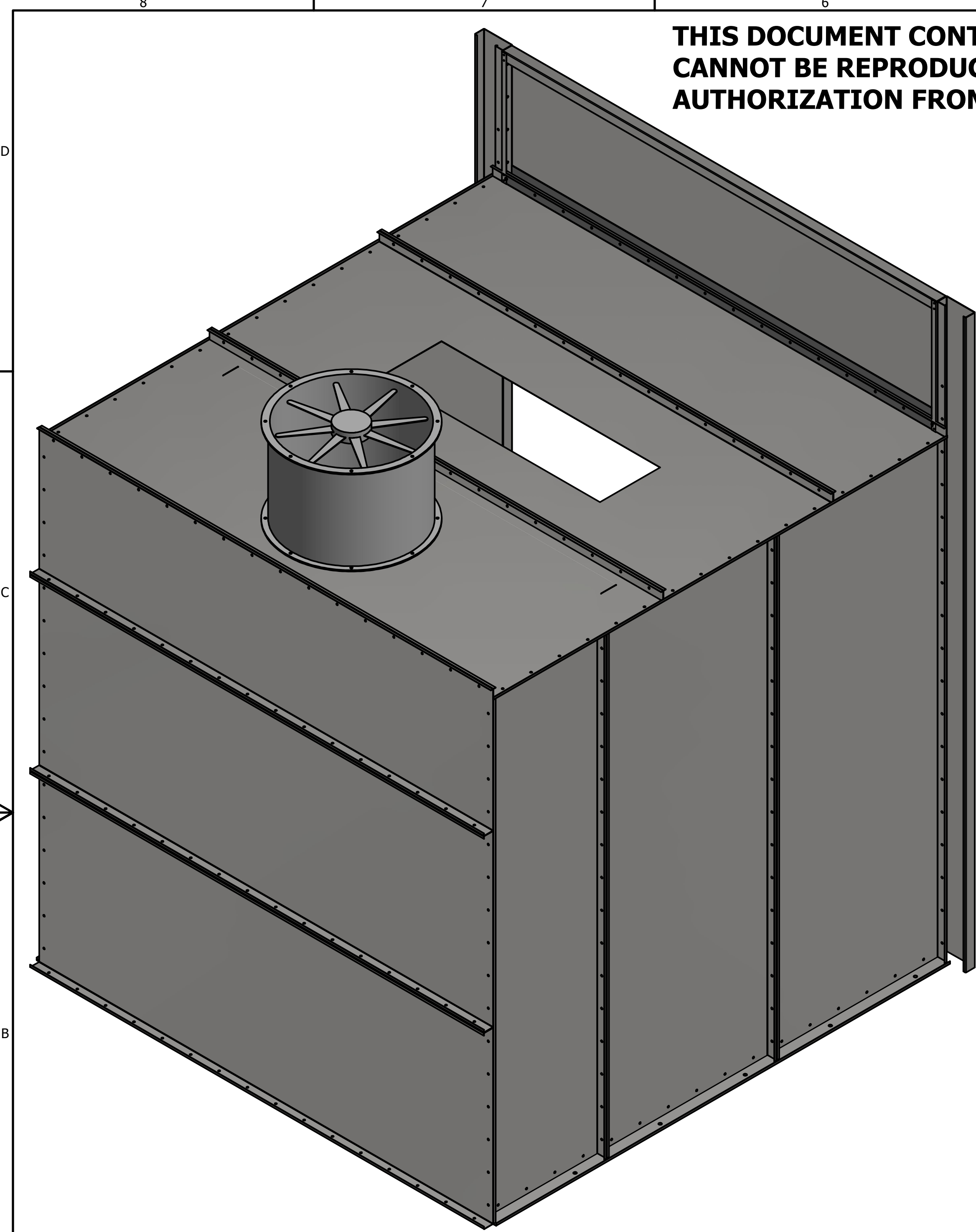
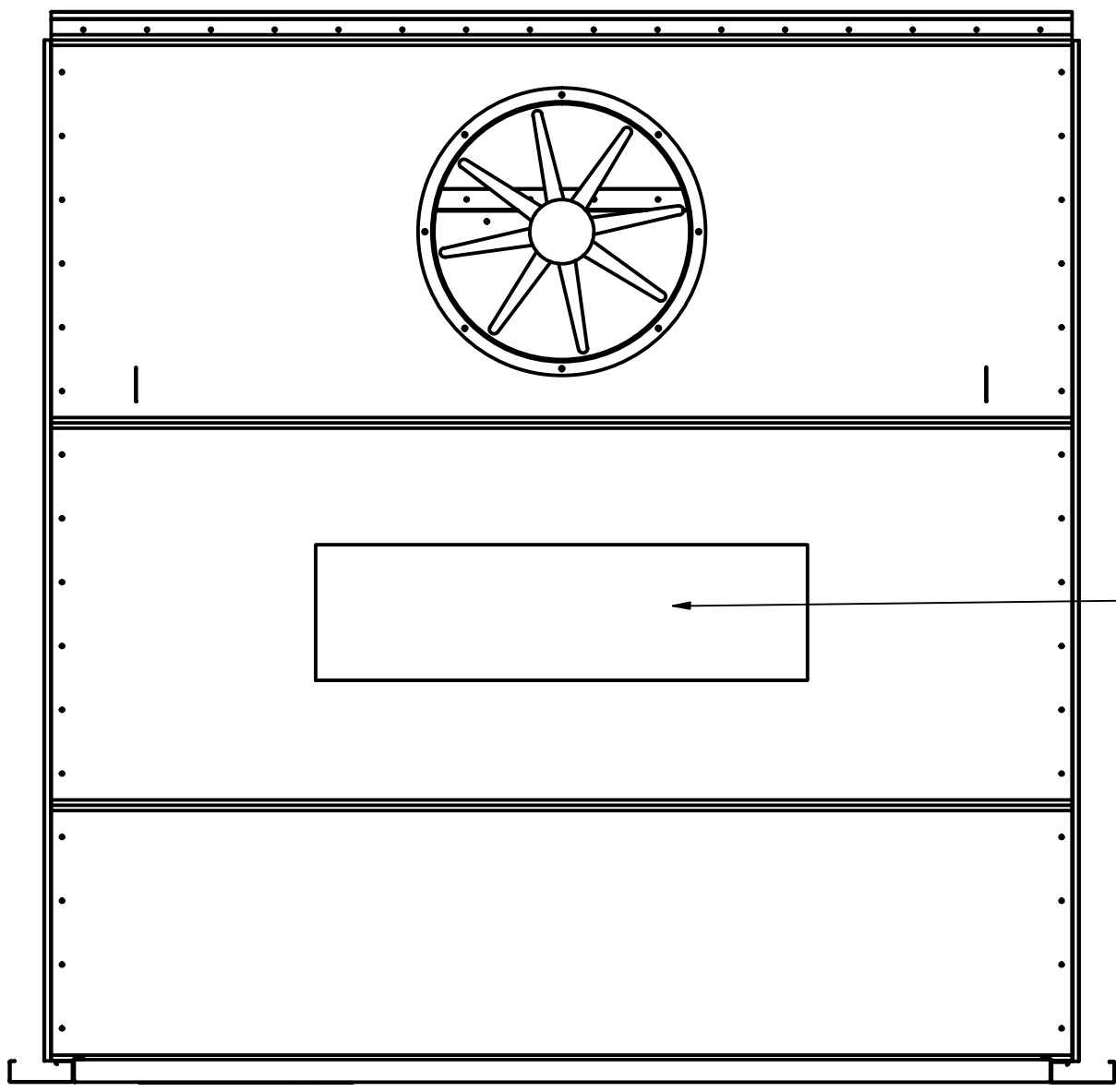

RGI LED LIGHT 4' - 4 LED TUBES

(16) 20" X 20" EXHAUST FILTERS

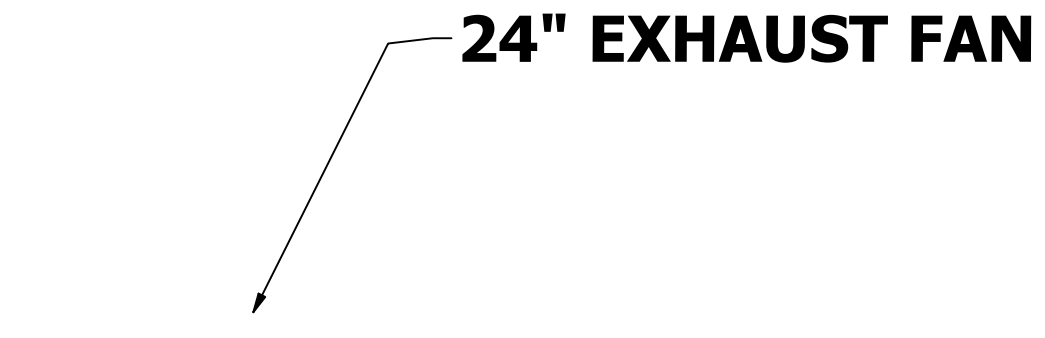

24" EXHAUST FAN

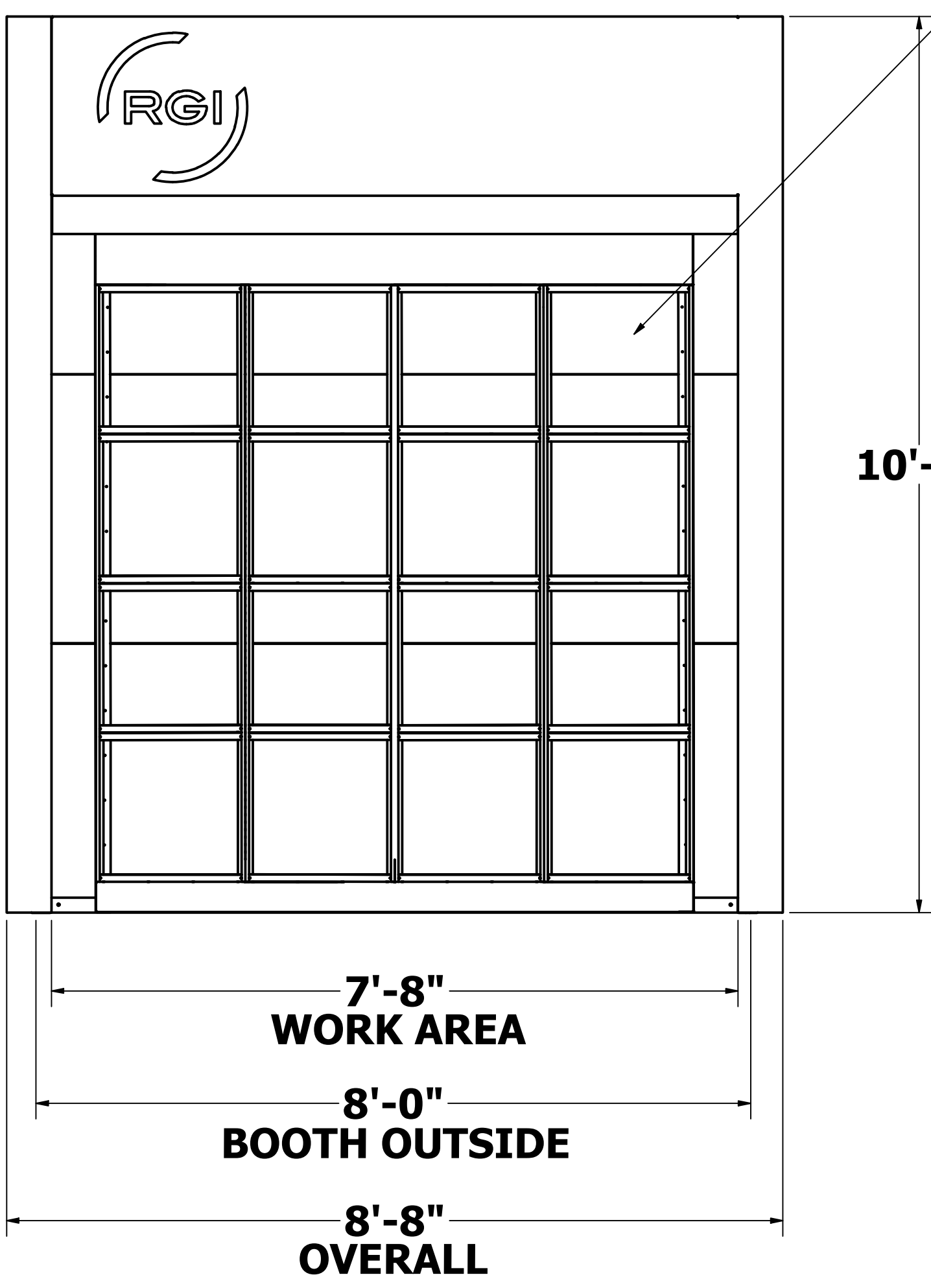

10'-0"

7'-8" WORK AREA
8'-0" BOOTH OUTSIDE
8'-8" OVERALL

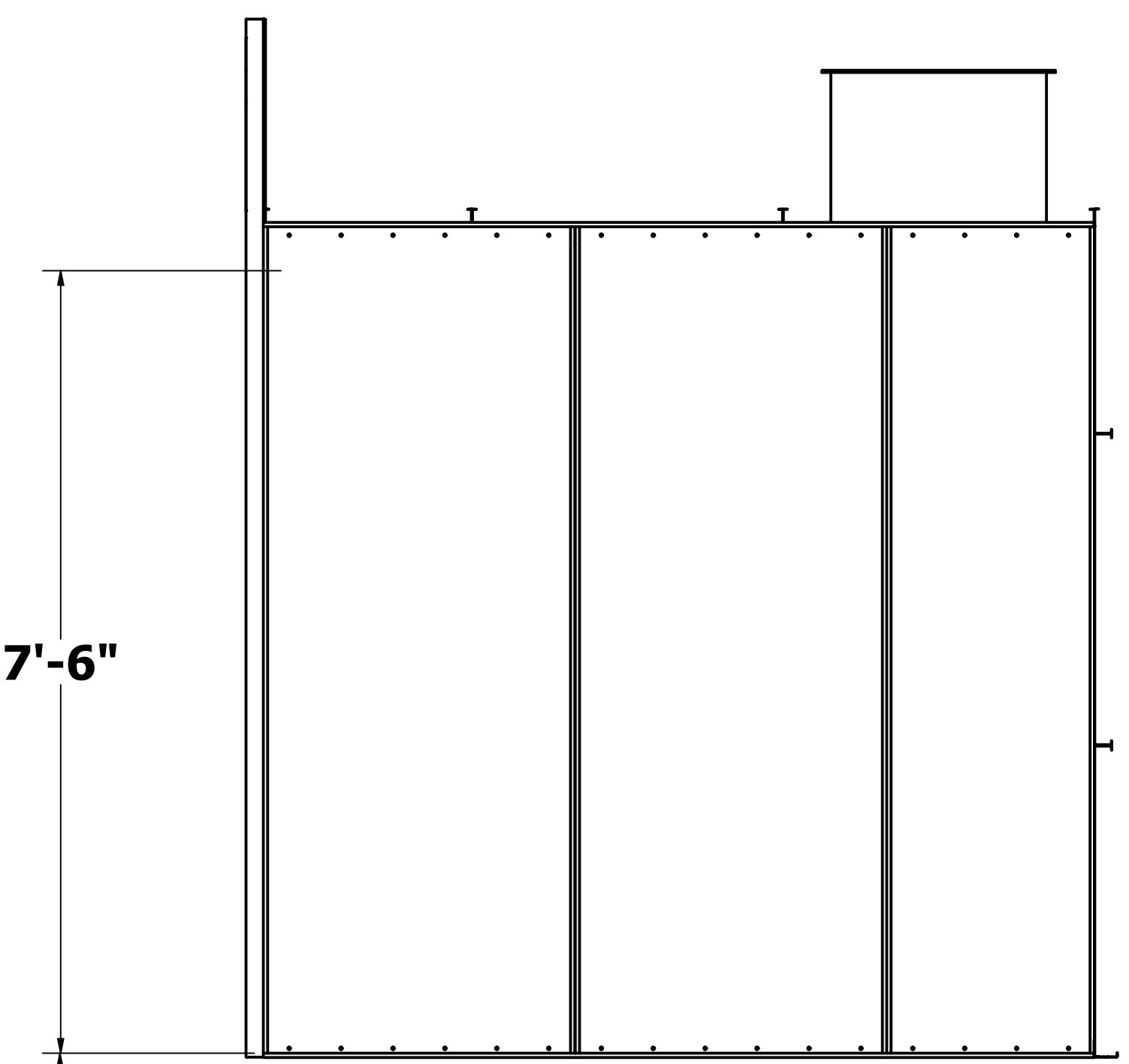

7'-6"

CLEARANCE UNDER FIRE FLASHING

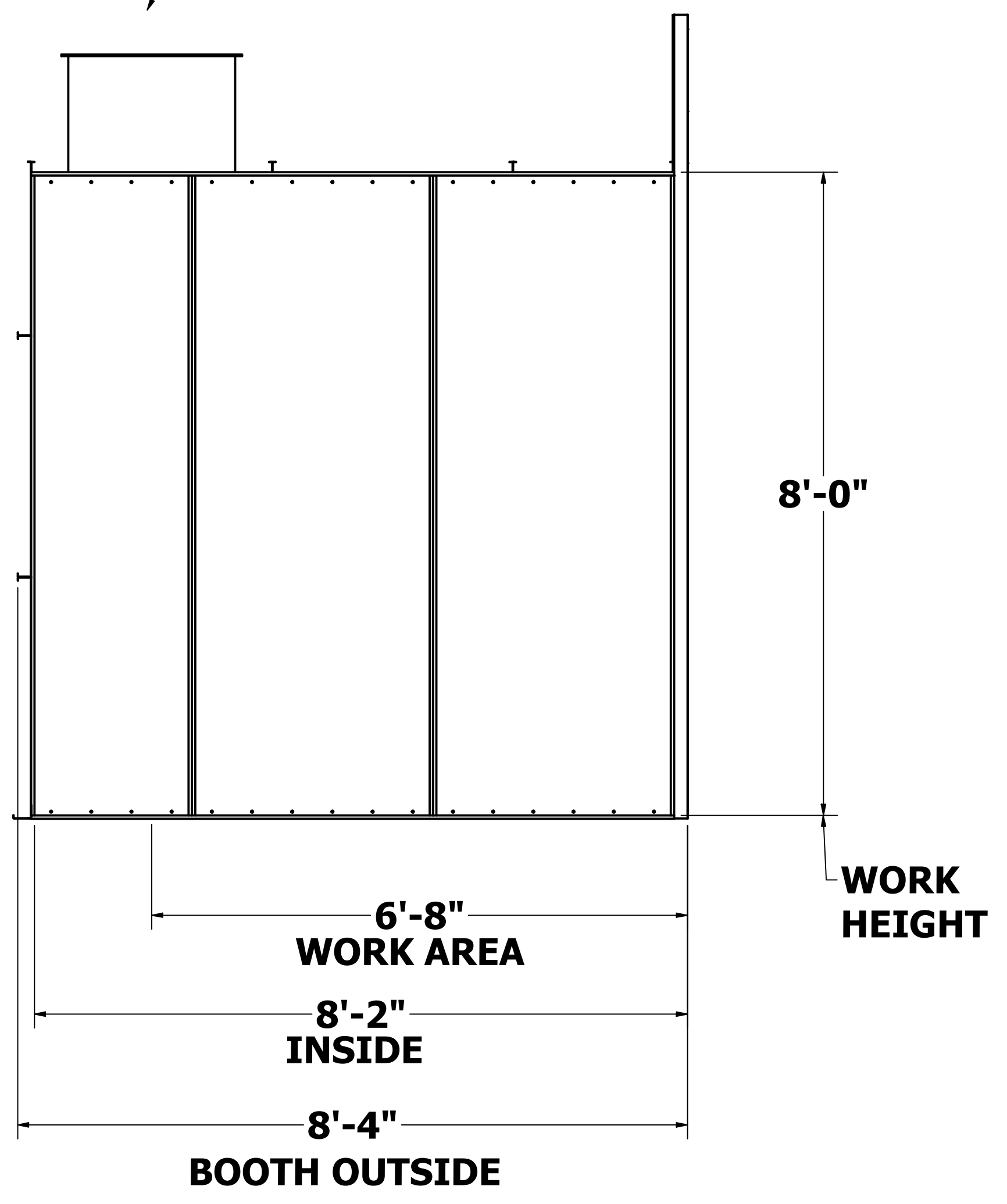

8'-0"

WORK HEIGHT

6'-8" WORK AREA
8'-2" INSIDE
8'-4" BOOTH OUTSIDE

DRAWN	david	7/21/2021	RGI SPRAY BOOTHS	
CHECKED			OPEN FACE	
QA			8W X 8H X 8DP	
MFG			FAN 24	
APPROVED			SIZE	DWG NO
MATERIAL			D	REV
			OPEN FACE 8W X 8H X 8DP_FAN 24	
			0.06 : 1	SHEET 1 OF 1

PARTS LIST			
ITEM	QTY	PART NUMBER	DESCRIPTION
P63	5	WP96X36	
P57	3	WP96X24	
Z96	2	ZC96	
FP13	1	FP96X36_24_FAN	
P88	1	WPLF96X36	
FN24	1	FAN 24	
F96	3	FLOOR CHANNEL 96	
P66	1	OPEN FACE 8'H HEADER SUPPORT 120 X 6 RIGHT	
P67	1	OPEN FACE 8'H HEADER SUPPORT 120 X 6_LEFT	
L1	1	RGI LOGO HEADER	
P90	1	OPEN FACE 8' HEADER PANEL 92 X 24 WITH 6" FIRE FLASHING(WITH OPEN FACE 8'W HEADER SUPPORT U CHANNEL)	
P89	1	WP96X26	
FF80	4	FILTER FRAME 80 X 20	
CP48	1	PLENUM FILTER FRAME BASE 80 X 4	
CP52	1	PLENUM FILTER FRAME SIDE 96 X 36 RIGHT	
CP53	1	PLENUM FILTER FACE PLATE - 80 X 20	
CP54	1	PLENUM FILTER FRAME SIDE 96 X 36_LEFT	
P91	1	WPTF96X36	



THIS DOCUMENT CONTAINS CONFIDENTIAL AND PROPRIETARY INFORMATION THAT CANNOT BE REPRODUCED OR DIVULGED, IN WHOLE OR IN PART, WITHOUT WRITTEN AUTHORIZATION FROM RGI SPRAY BOOTHS

DRAWN DAVID FRISK	8/9/2019	RGI SPRAY BOOTHS	
CHECKED		TITLE	
QA		OPEN FACE 8W X 8H X 8DP	
MFG		SIZE	DWG NO
APPROVED		D	OPEN FACE 8W X 8H X 8DP_PARTS
MATERIAL		SCALE	REV
		.10	1
			SHEET 1 OF 1

THIS DOCUMENT CONTAINS CONFIDENTIAL AND PROPRIETARY INFORMATION THAT CANNOT BE REPRODUCED OR DIVULGED, IN WHOLE OR IN PART, WITHOUT WRITTEN AUTHORIZATION FROM RGI SPRAY BOOTHS

D

D

C

C

B

B

A

A

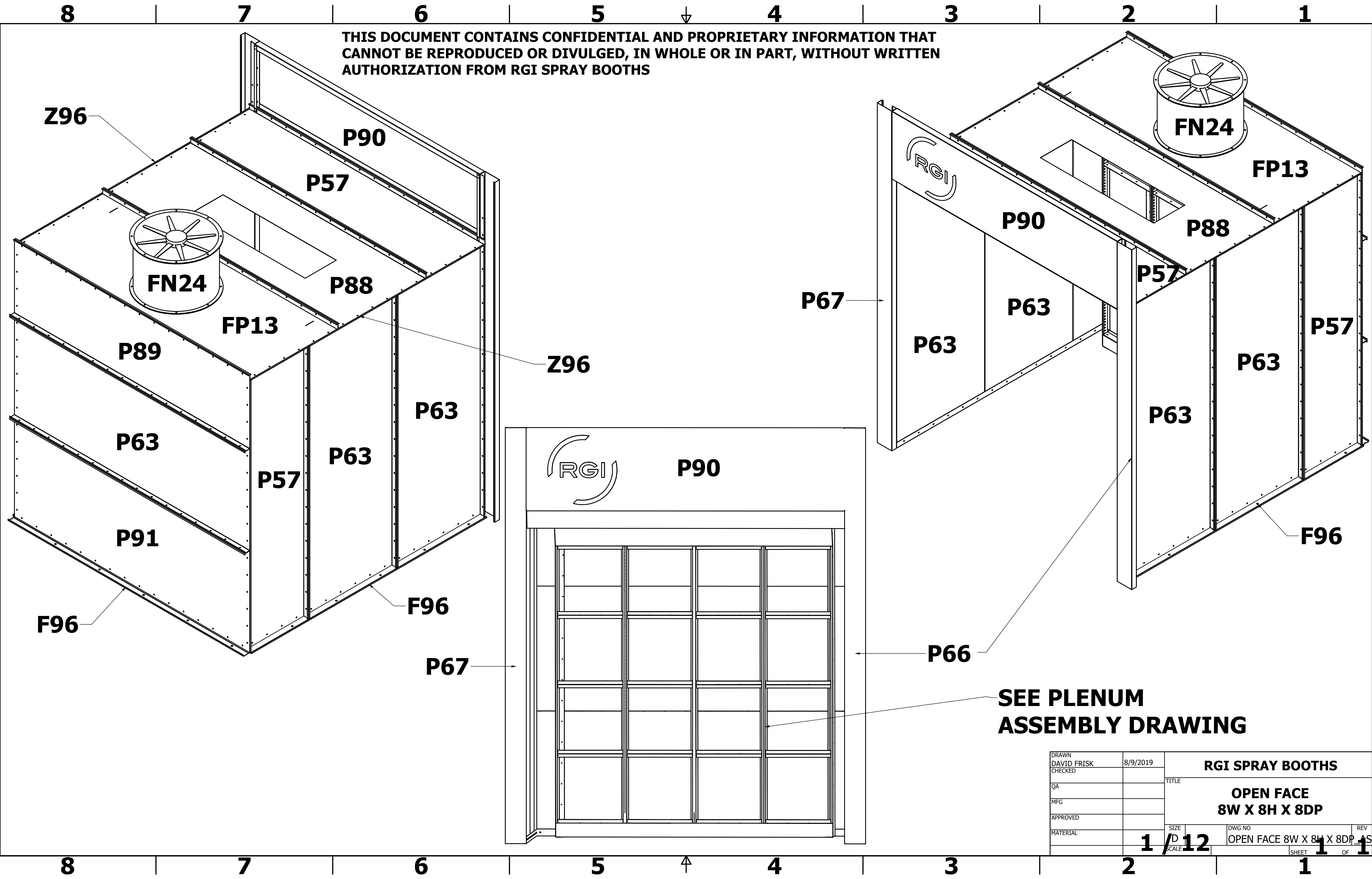

DRAWN	DAVID FRISK	8/9/2019	RGI SPRAY BOOTHS	
CHECKED			TITLE	
QA			OPEN FACE	
MFG			8W X 8H X 8DP	
APPROVED			SIZE	DWG NO
MATERIAL			1 / 12	OPEN FACE 8W X 8H X 8DP
			SCALE	REV
				1
				1
				1

PARTS LIST			
ITEM	QTY	PART NUMBER	DESCRIPTION
FF80	8	FILTER FRAME 80 X 20	
CP48	1	PLENUM FILTER FRAME BASE 80 X 4	
CP52	1	PLENUM FILTER FRAME SIDE 96 X 36 RIGHT	
CP53	1	PLENUM FILTER FACE PLATE - 80 X 20	
CP54	1	PLENUM FILTER FRAME SIDE 96 X 36 LEFT	

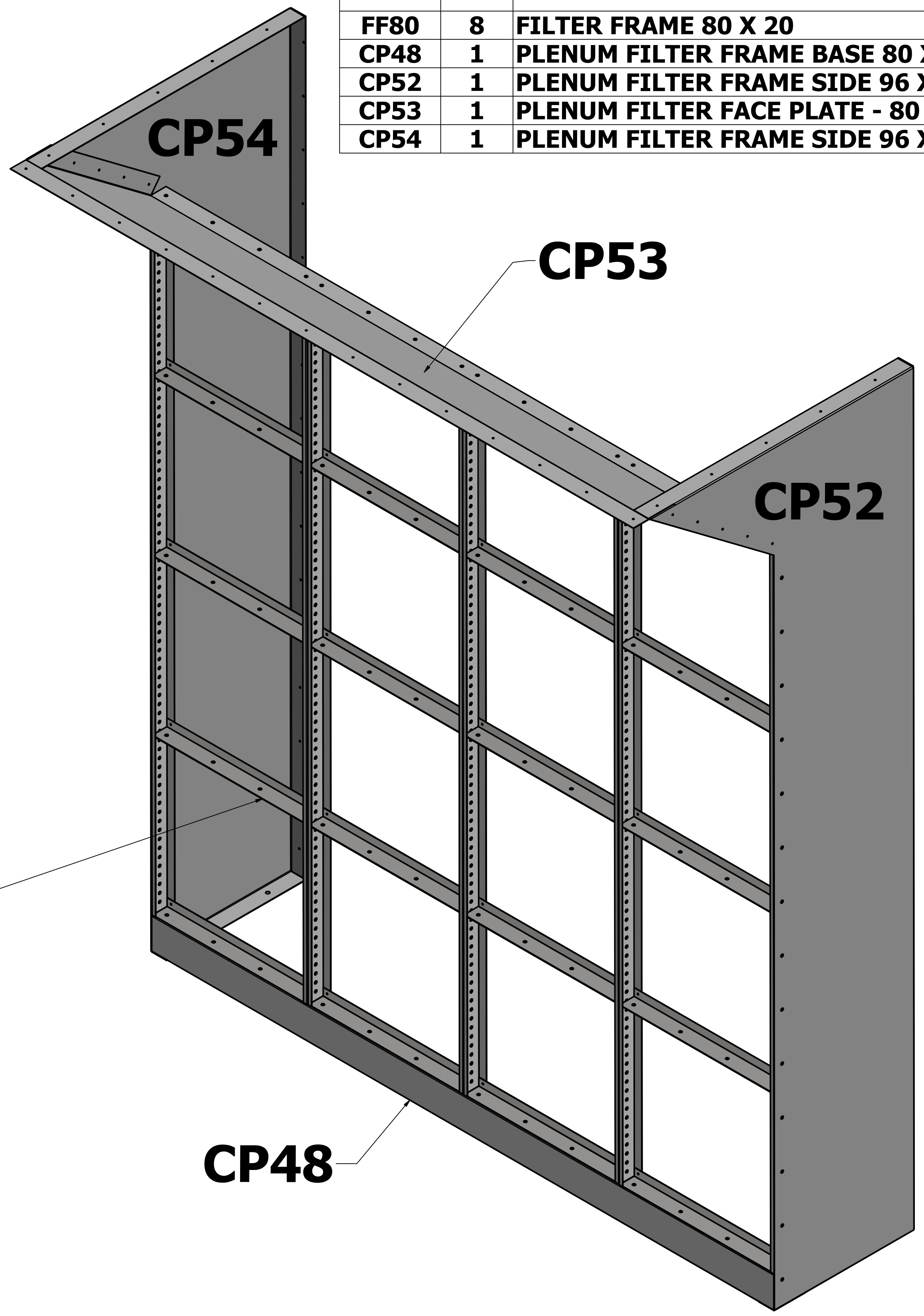

**FF80 (4 PLACES)
PLACE VERTICAL**

THIS DOCUMENT CONTAINS CONFIDENTIAL AND PROPRIETARY INFORMATION THAT CANNOT BE REPRODUCED OR DIVULGED, IN WHOLE OR IN PART, WITHOUT WRITTEN AUTHORIZATION FROM RGI SPRAY BOOTHS

DRAWN david	7/21/2021	RGI SPRAY BOOTHS	
CHECKED		TITLE PLENUM FILTER ASSEMBLY 96" CEILING 80" WIDE	
QA		SIZE D	DWG NO
MFG		REV	
APPROVED		SCALE .15	
MATERIAL		SHEET 1 OF 1	

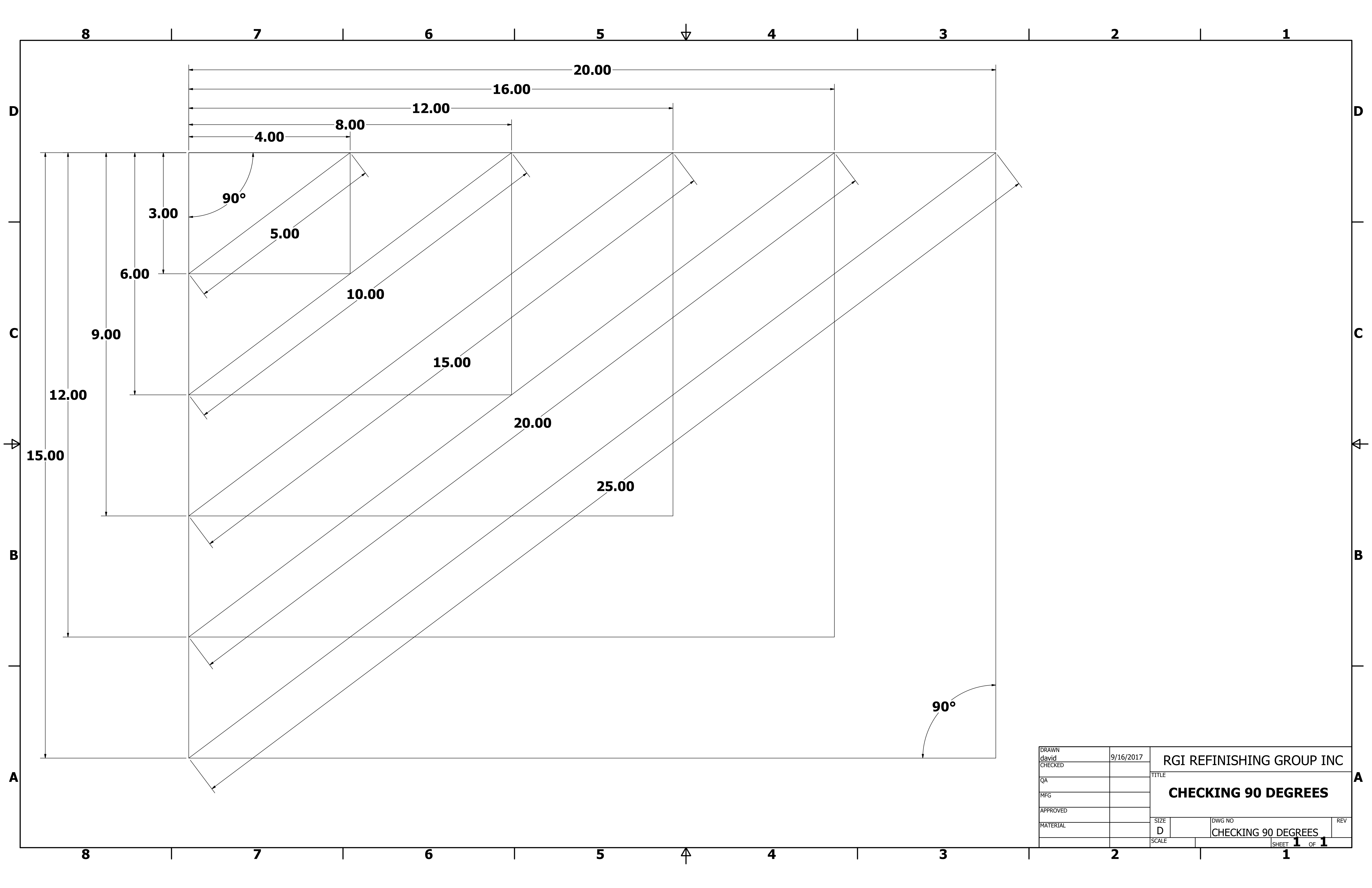

DRAWN	david	9/16/2017	RGI REFINISHING GROUP INC	
CHECKED			TITLE	
QA			CHECKING 90 DEGREES	
MFG				
APPROVED				
MATERIAL			SIZE	DWG NO
			D	CHECKING 90 DEGREES
			SCALE	REV
				SHEET 1 OF 1

1/4-20 X 0.750 BOLT & NUT TYPICAL

**USE SELF TAPPING SCREWS WHERE
NO MATING 0.312 HOLE EXISTS.**

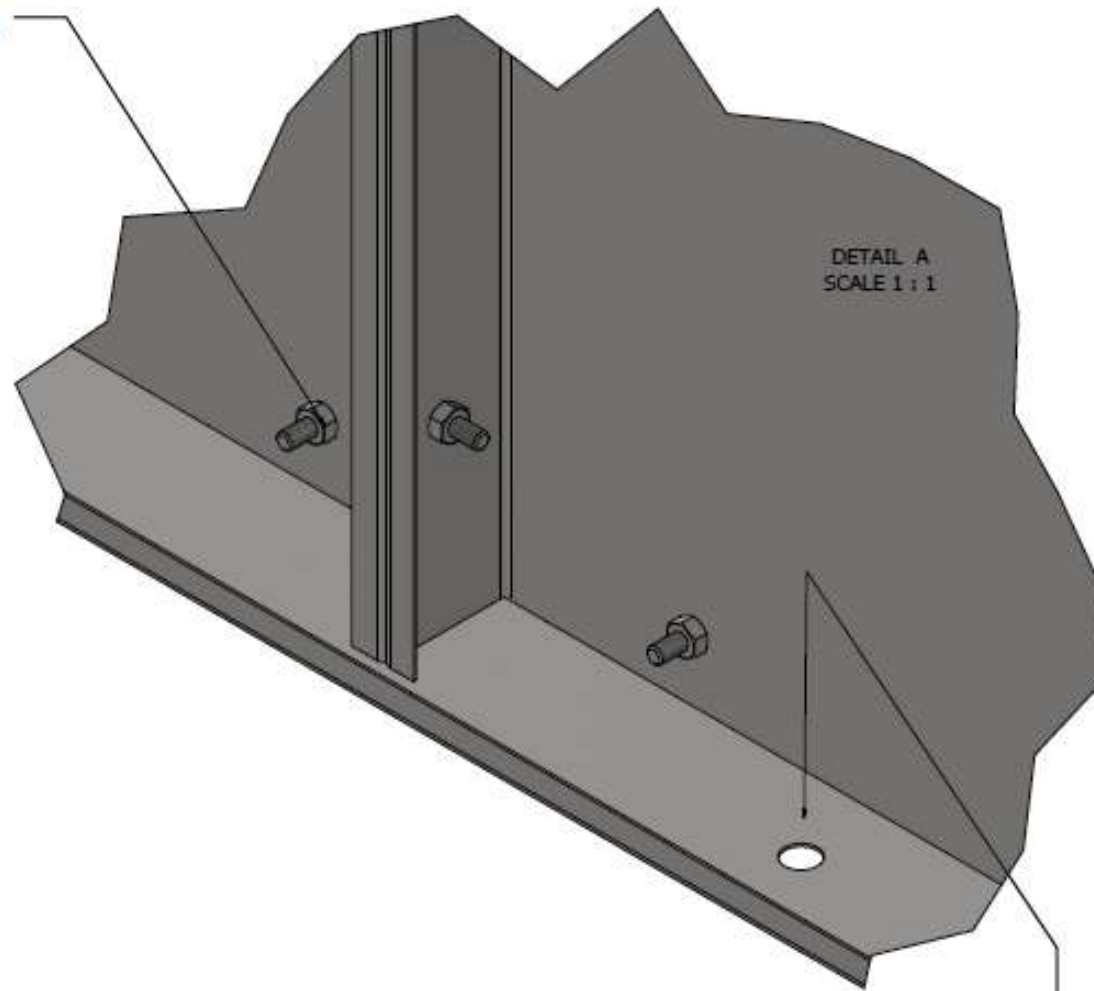

CONCRETE ANCHOR

DRAWN	4/28/2018	RGI SPRAY BOOTHS	
CHECKED		TITLE	
QA		TYPICAL SPRAY BOOTH ASSEMBLY	
MFG		SIZE	DWG NO
APPROVED		D	VECTOR 27 DUAL INTAKE FILTER 1
MATERIAL		SCALE	1 / 16
			SHEET 1 OF 1

8 7 6 5 4 3 2 1

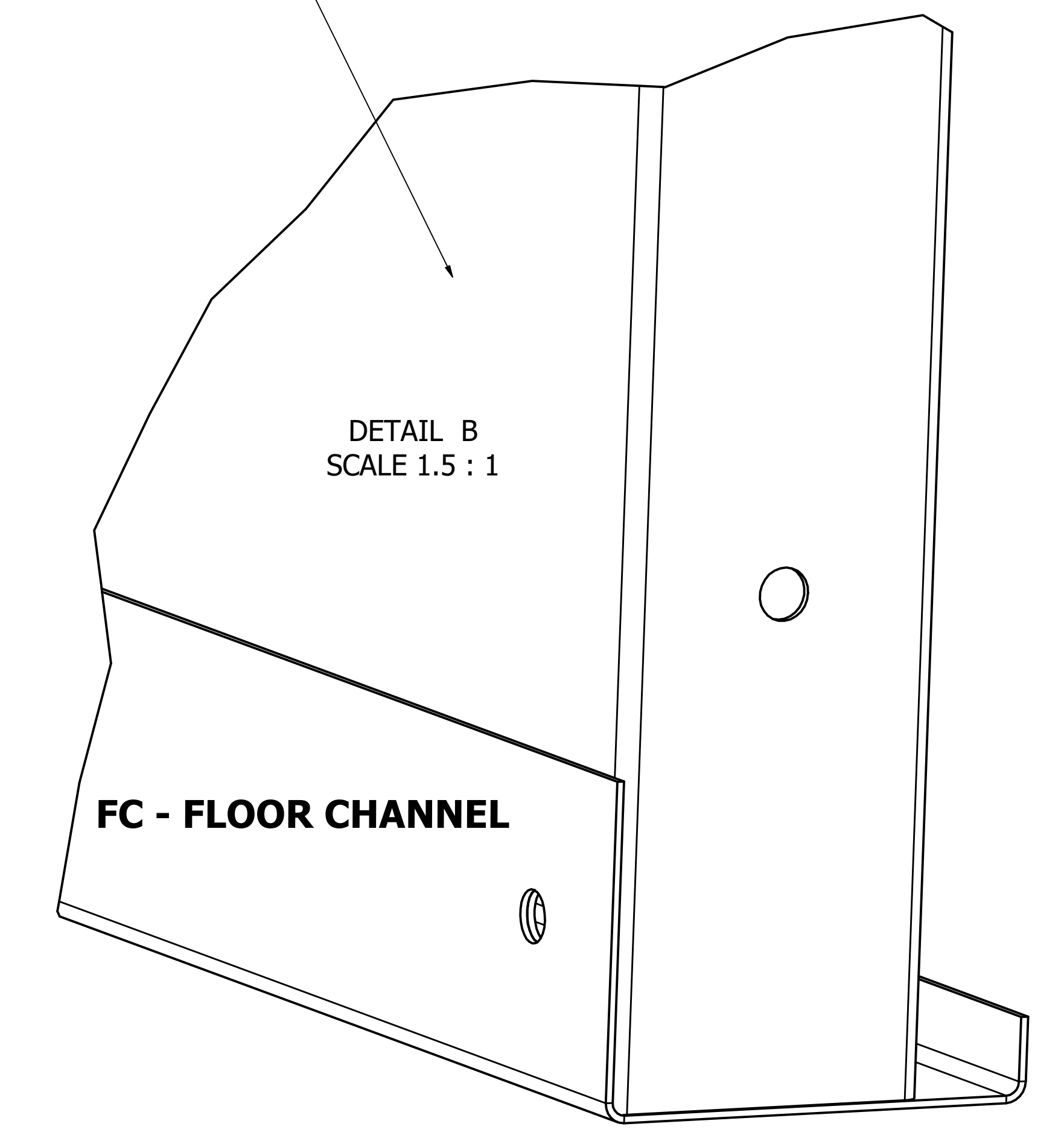
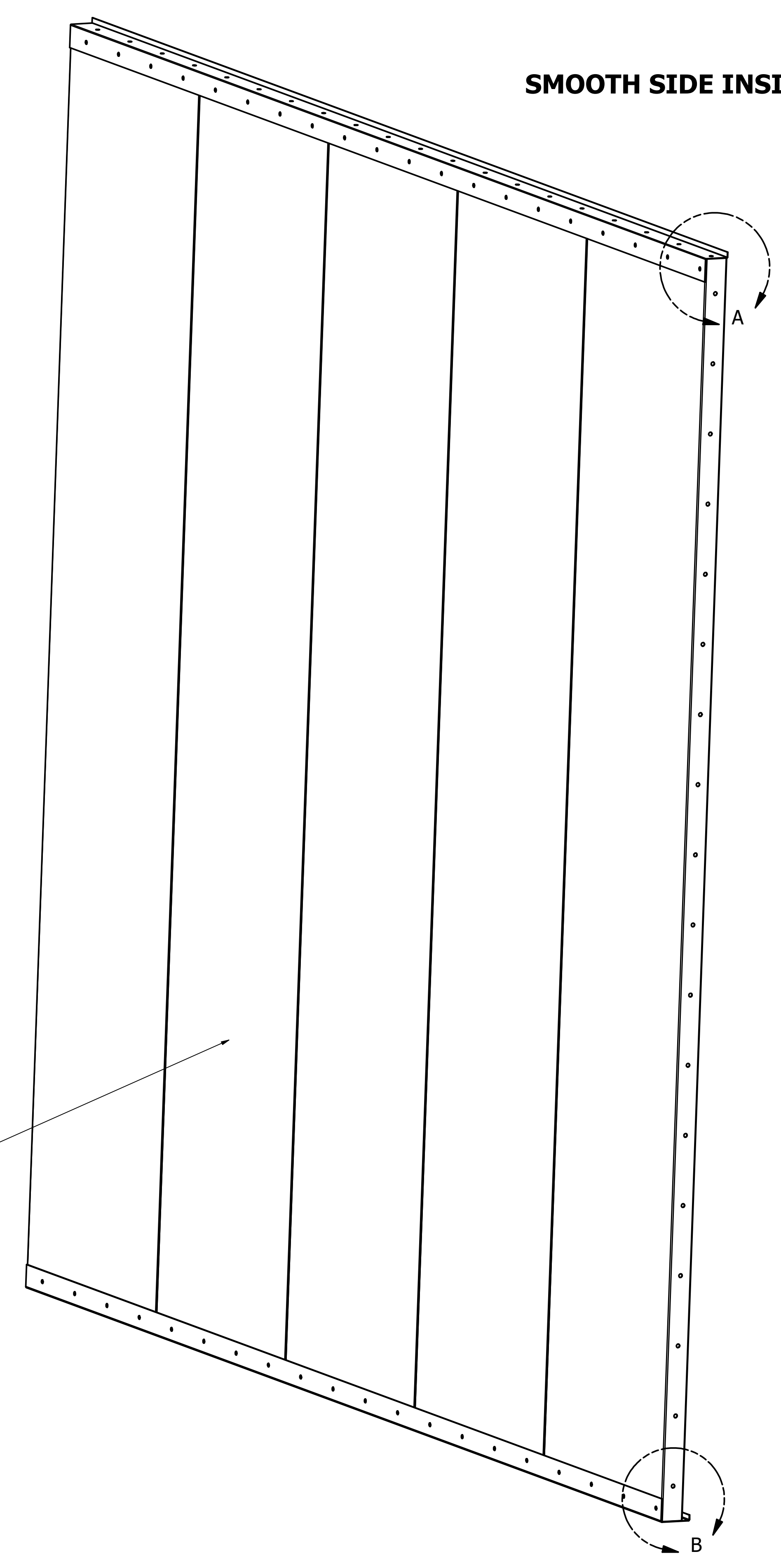
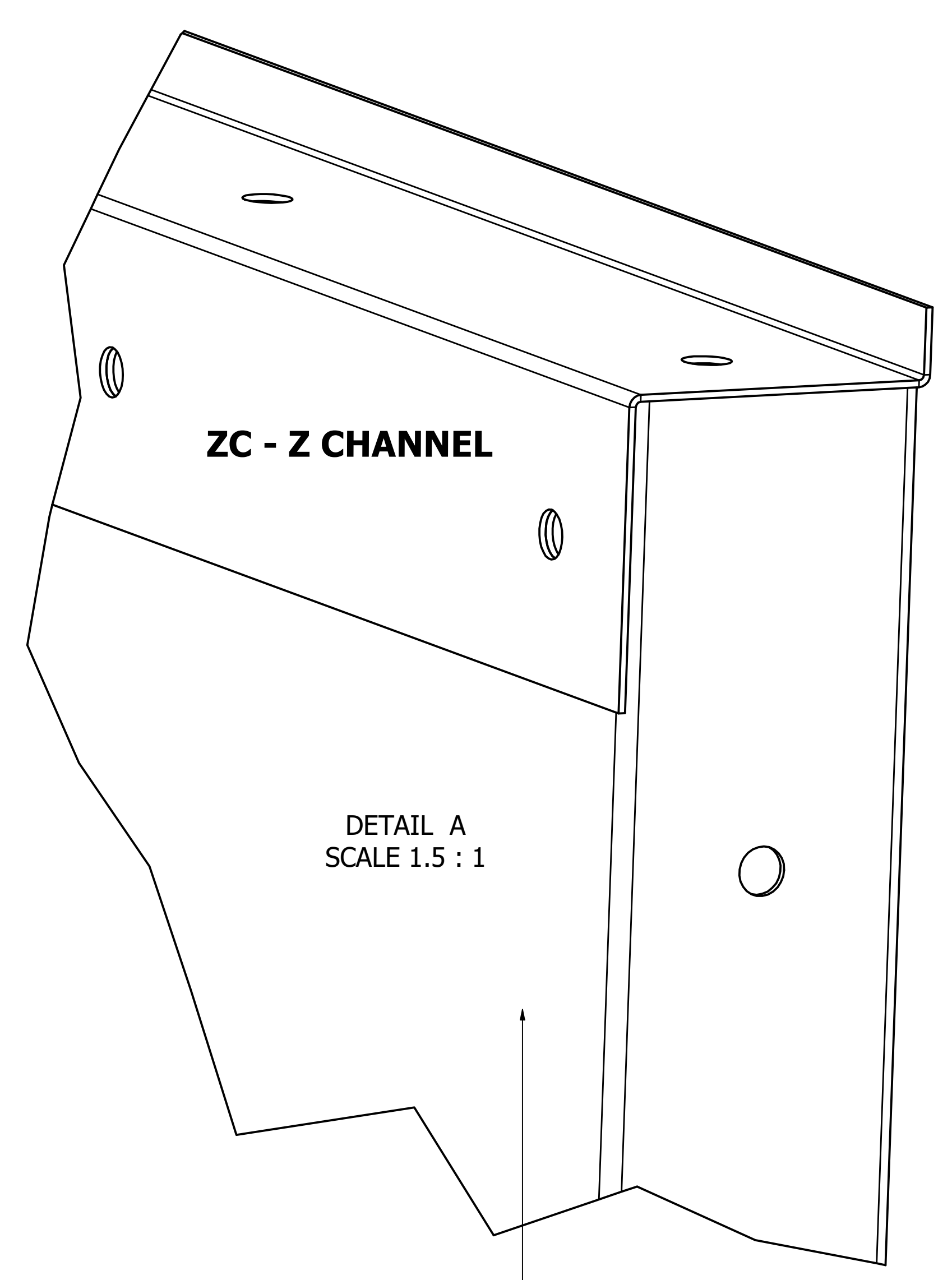

THIS DOCUMENT CONTAINS CONFIDENTIAL AND PROPRIETARY INFORMATION THAT CANNOT BE REPRODUCED OR DIVULGED, IN WHOLE OR IN PART, WITHOUT WRITTEN AUTHORIZATION FROM RGI SPRAY BOOTHS

DRAWN david	10/28/2021	RGI SPRAY BOOTHS	
CHECKED		TITLE ZC - Z CHANNEL FC - FLOOR CHANNEL ASSEMBLY	
QA		SIZE D	DWG NO ZC & FC ASSEMBLY EXAMPLE
MFG		SCALE .15	REV
APPROVED		SHEET 1 OF 1	
MATERIAL			

8 7 6 5 4 3 2 1

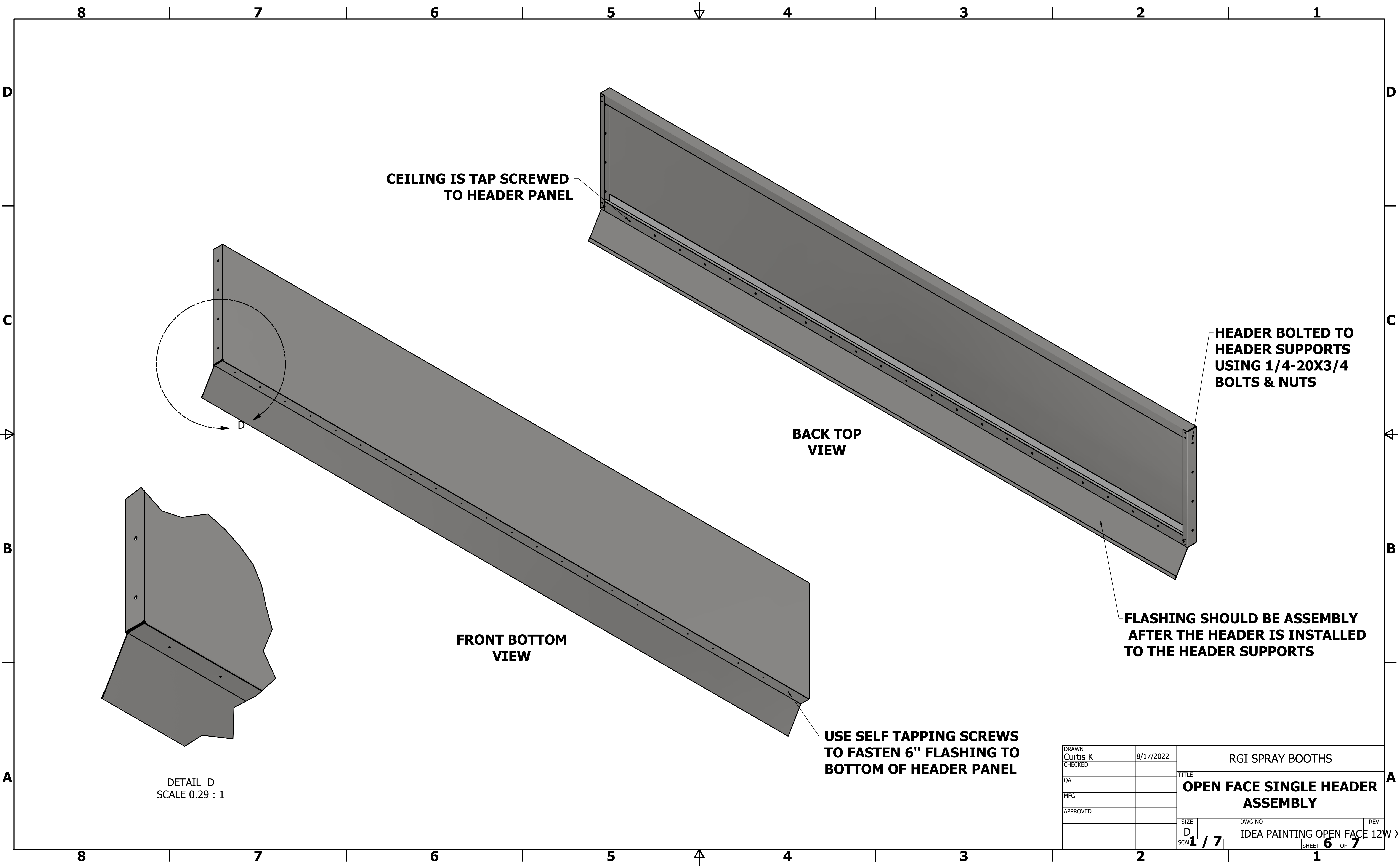

DRAWN Curtis K	8/17/2022	RGI SPRAY BOOTHS	
CHECKED		TITLE OPEN FACE SINGLE HEADER ASSEMBLY	
QA		SIZE D	DWG NO IDEA PAINTING OPEN FACE 12W X
MFG		SCALE 1 / 7	REV
APPROVED		SHEET 6 OF 7	

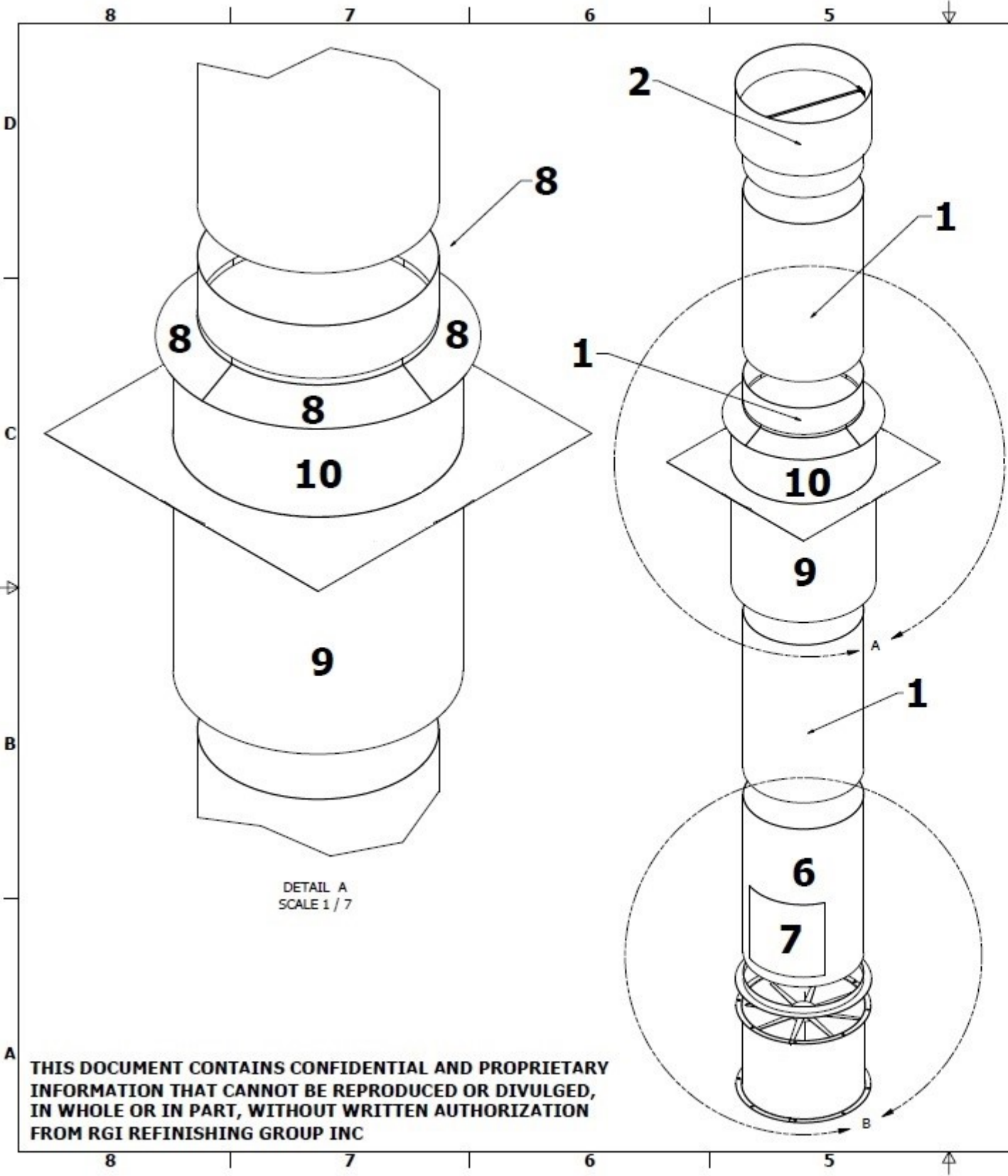

PARTS LIST			
ITEM	QTY	PART NUMBER	EXTRA QTY
1	2	DUCT 48" LONG 20GA	
2	1	DUCT DAMPER 24" HEIGHT 20GA	
3		45 DEG ELBOW (ONLY IF REQUIRED) 20GA	
4	1	FAN	
5	1	RING 2" HEIGHT	
6	1	DUCT INSPECTION 48" LONG 20GA	
7	1	DUCT INSPECTION COVER 20GA	
8	4	DUCT QUARTER SECTION SKIRT (COLLAR) 20GA	
9	1	(NOTE 2) DUCT FIRE WRAP DUCT DIAMETER + 2" - LENGTH 36" 20GA	
10	1	DUCT FLASHING DUCT DIAMETER + 6" 20GA 15" HEIGHT	

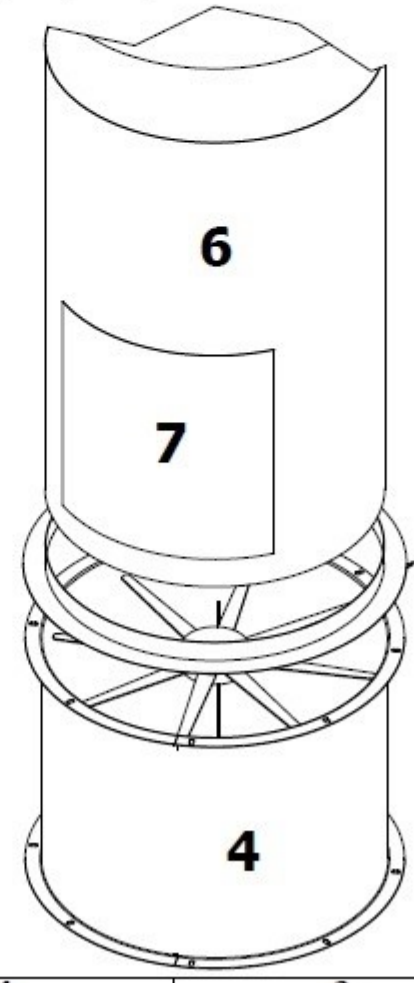

- NOTES:**
- 1) MALE (CRIMPED END) OF DUCT MUST BE UP & FEMALE END IS DOWN
 - 2) FIRE WRAP IS USED ON WOODEN ROOFS
 - 3) ALLOW 2" FOR EACH CONNECTION

DETAIL B
SCALE 1 / 7

ORDER		CUSTOMER	
DESIGN		RGI SPRAY BOOTHS	
DATE	2/12/2021	TITLE	
BY		DUCTING KIT	
APPROVED		SIZE	DWG NO
MATERIAL		D	FAN & DUCT KIT
		SCALE	1/14
		SHEET	1 OF 1

THIS DOCUMENT CONTAINS CONFIDENTIAL AND PROPRIETARY INFORMATION THAT CANNOT BE REPRODUCED OR DIVULGED, IN WHOLE OR IN PART, WITHOUT WRITTEN AUTHORIZATION FROM RGI REFINISHING GROUP INC